



Amhara Regional Agricultural Research Institute



Proceedings of the 4th Annual Regional Conference on Completed Research Activities

4-7 November, 2009

Bahir Dar, Ethiopia



Editor: Wondimu Bayu

Amahara Regional Agricultural Research Institute

P.o.Box 527

Bahir Dar, Ethiopia

Tel: +251 058 220 64 00

Fax: +251 058 2266077

Website: www.AR-ARI.ORG

E-mail: arari@ethionet.et

The opinions expressed in this volume are those of the authors and do not necessarily reflect the view of the institute.

ARARI encourages fair use of this material. Proper citation is requested.

Correct Citation: Wondimu Bayu (ed). 2012. Proceedings of the 4th Annual Regional Conference on Completed Research Activities, 4-7 November, 2009. Amhara Regional Agricultural Research Institute. Bahir Dar, Ethiopia.

Published June, 2012

Table of Contents

FOREWORD.....	IV
CROP	1
Performance evaluation of released faba bean varieties at Ankober	2
Faba bean (<i>Vicia faba</i> L.) variety evaluation in Wag-himra and Lasta areas.....	8
Enzyme linked immune-sorbent assay based survey on bacterial wilt and viral diseases of potato in western Amhara Region	18
Split application of nitrogen fertilizer for lowland rice production on Vertisols of Fogera plain	33
Fruit tree species in the wilderness: Species composition and level of use in western Amhara	41
LIVESTOCK.....	58
Characterization of milk production and marketing systems in Bure district of Amhara National Regional State, Ethiopia.....	59
Production system and linear body measurements of Washera sheep in the Western highlands of the Amhara National Regional State, Ethiopia.....	73
Current fish status of Koga River and dam in West Gojjam, Ethiopia.....	91
Goat marketing in northern highlands of Ethiopia: The case of <i>Wag-Hämera- Mekelle</i> supply shed.....	101
On-farm verification of improved feeding systems for highland sheep in North Shewa zone of Amhara region.....	113
On-farm demonstration of splitting queen rearing technique in Meket woreda, Eastern Amhara	120
Demonstration of maize and noug cake mixture supplementation for women-focused small scale sheep fattening in Yilmana Densa woreda.....	126

Characterization of Gumuz sheep under traditional farmer practice in Metema woreda of Amhara Regional State.....	132
Feedlot weight gain and carcass production efficiency of Washer sheep under concentrate supplementation.....	142
SOIL AND WATER MANAGEMENT	153
Double cropping and supplementary irrigation potential of harvested drainage water on Vertisols at Enewari district in North Shewa.....	154
Evaluation of double cropping and supplementary irrigation of chickpea using drainage water on Vertisols at Dembia district in North Gondar	166
On-farm evaluation of Vertisol management techniques at Bichena district in East Gojjam.....	172
Effect of in-situ moisture conservation structures for improving the yield of field crops in moisture stress areas at East Belessa district in North Gondar	179
Quantifying rill erosion by surface runoff on cultivated lands at Debre Mewi watershed in West Gojjam	191
Evaluation of deficit irrigation for potato production at Sekota, Wag Himra	204
AGRICULTURAL MECHANIZATION & FOOD SCIENCE.....	210
Modification and evaluation of sorghum thresher	211
FORESTRY	219
Floristic diversity, regeneration status and vegetation structure of the woodland vegetation in Metema area, Amhara National Regional State, Northwestern Ethiopia	220
Plant community and ecological analysis of the woodland vegetation in Metema area, Amhara National Regional State, Northwestern Ethiopia	238
Adaptation of indigenous economically important multipurpose trees in the dry lowlands of Abergele.....	257
INSTRUCTIONS TO AUTHORS.....	262

Foreword

Researchers' responsibility does not end with conducting research, data collection and generating information or knowledge. They have obligation to publish and share research results to the public and professional community. It is only through this process that their research findings enter to the existing knowledge database and serve as a building block for the advancement of science in their field of investigation. It is only by doing so that researchers could show the relevance of their efforts to the development agenda of the country and also encourage government and donors to allocate adequate budget and facility for research. Therefore, publishing research results is as equally important as conducting research. In view of this fact, the Amhara Regional Agricultural Research Institute is pioneer in organizing annual completed experiments review forum in the National Agricultural Research System. In this forum each research finding is critically evaluated, compiled and finally made available for users in the forum of proceedings. In the current proceeding numbers of research findings of immense relevance to the end users are compiled in the fields of crop and livestock production, forestry, soil and water management, and agricultural mechanization. I greatly hope that the research results in this proceeding would have impact towards improving agricultural productivity in our region and the country at large. The proceeding would also be a valued reference material for researchers, University lecturers, agricultural extension workers and investors in agriculture. Finally, I would like to thank those who shared their research findings in this proceeding and also encourage all researchers to publish their findings. I also would like to acknowledge the editor and reviewers for their technical input reflected on the scientific standard of this proceeding.

Yigzaw Dessalegn (PhD)
Deputy Director General
Amhara Regional Agricultural Research Institute
Bahir Dar, Ethiopia



CROP

Performance evaluation of released faba bean varieties at Ankober

Wondafrash Mulugeta¹ and Daniel Admasu

¹Email:wendafrash@gmail.com

Debre Birhan Agricultural Research Center, P.O. Box 112, Debre Birhan

Abstract

Fourteen released and one local faba bean varieties were evaluated for two years at Ankober so as to select adaptable and high yielding varieties for the drained soils of high altitude areas in North Shewa. The experimental design was RCBD with three replications. The combined analysis of variance over the two years showed no significant interaction between variety and year for all the characters except for hundred seed weight. Varieties Gebelcho, Walki, Degaga and Moti gave the highest seed yield of 4536.9, 4450.2, 4358.5 and 4351.4 kg ha⁻¹, respectively, and had the respective yield advantage of 17.44%, 15.20, 12.82, and 12.64% over Ankober local. The same varieties had the respective hundred seed weights of 64.4, 50.0, 43.4, and 63g while Ankober local had 38.5 g. Therefore, considering the importance of diversifying varieties to avoid the risk of relying only on one variety (local variety) and based on seed yield, hundred seed weight and biomass yield as the major selection criteria, respectively Gebelcho and Walki are recommended for production on the well drained brown soils of Ankober and similar environments.

Key words: Faba bean, released varieties.

Introduction

Grain legumes are important components of various farming systems in many parts of the world. Legumes are enjoying a resurgence in interest and an enhanced level of consumption as sole protein source due to an outrageous increase in local prices of animal products, which was also a consequence of a steep decline in both real income and purchasing power of people in most African countries in the 1980s (Nwokolo,1996). In Ethiopia also pulses serve as major source of protein for the bulk of the population and have the capacity to fix atmospheric nitrogen and improve soil fertility (Yohannes, 2000). Among pulse crops in Ethiopia, faba bean is the major one and contributes not only to the incomes of more than 3,841,587 smallholders and in nutritional terms to all residents in highland, mid-highland and urban areas of the country, but also serves as break crops for cereal crops. The crop serves as a source of cash to the farmers and generates foreign currency to the country (Gemechu *et al.*, 2006;

Gezahegn and Dawit, 2006). In Ethiopia, Amhara Region ranks first in terms of faba bean area coverage and production in 2008/09 main cropping season (CSA, 2009). However, its productivity has been low in farmers' fields (1.0-1.4 tone ha⁻¹). The low productivity is largely attributable to the lack of high yielding varieties having tolerance to diseases, insect pests and to stress environments like waterlogging. This study was carried out, therefore, to evaluate the adaptability and productivity of nationally and regionally released faba bean varieties so as to select and recommend for production in the drained soils of high altitude areas like Ankober and similar areas in North Shewa.

Materials and methods

The experiment was conducted in the year 2007 (on-station) and 2008 (on-farm) at Ankober (9⁰38" N latitude and 39⁰44" E longitude with an altitude of 3140 m above sea level), representing drained brown soils of high altitude areas in North Shewa. According to the unpublished data of the National Meteorology Agency of Ethiopia, Ankober had twenty years average annual rainfall of 1793 mm and the respective maximum and minimum temperatures of 27.35 and 13.04 °C. A total of 15 nationally and regionally released varieties with the local check from Ankober were included in the study (Table 1). A randomized complete block design with three replications was used. Each plot had four rows with the spacing of 40 cm between rows and 5 cm between plants in each of 4 m long rows. Sowing was done on 13 July 2007 and 24 June 2008. DAP fertilizer at the rate of 100 kg ha⁻¹ was applied at sowing. Data on seed and biomass yields, hundred seed weight, plant height, days to 50% flowering, days to 100% maturity, number of seeds per pod, and number of pods per plant were recorded. Seed yield was taken only from the central two rows of each plot after discarding border rows. Analysis of variance for each location and combined analysis of variance over years were done following the standard procedure given by Gomez and Gomez (1984) using the SAS statistical package version 9.00 (SAS Institute INC., 2004). Variance ratio test for homogeneity of variance was carried out to determine the validity of the individual experiment for combined analysis. Combined analysis of variance was performed using PROC GLM procedure. Mean separation was carried out using Duncan's Multiple Range Test at 5% of significance.

Table 1. Specific traits and adaptation areas of released faba bean varieties evaluated in the adaptation trial at Ankober.

Released Varieties	Specific traits	1000 seed weight (g)	Altitude (m)	Reference
Gebelecho	Black root rot disease tolerance	797	1800-3000	MARD (2006)
Degaga	Tolerance to chocolate spot and rust	517	1800-3000	NAIA (2002)
Moti	Tolerance to chocolate spot and rust	781	1800-3000	MARD (2006)
Selale Kasim	Black root rot disease tolerance	346	2100-2700	NAIA (2002)
Wayu	Black root rot disease tolerance	312	2100-2700	NAIA (2002)
NC-58	Tolerance to chocolate spot and rust	449	1900-2300	NSIA (1998)
Mesay	Tolerance to chocolate spot and rust	428	1800-2300	NSIA (1998)
Tesfa	Tolerance to chocolate spot and rust	441	1800-2300	NSIA (1998)
Dagem	Black root rot disease tolerance	330	1800-2800	NAIA (2002)
Holeta-2	Tolerance to chocolate spot and rust	506	2300-3000	NAIA (2001)
CS 20 DK	Tolerance to chocolate spot and rust	476	2300-3000	NSIA (1998)
Bulga-70	Tolerance to chocolate spot and rust	440	2300-3000	NSIA (1998)
Lallo	Black root rot disease tolerance	330	1800-2800	NAIA (2002)
Walki	Black root rot disease tolerance	676	1800-2800	MARD (2008)

Results and discussion

Differences among years were statistically significant for seed and biomass yield, 100 seed weight, number of pods plant⁻¹ and plant height (Table 2). There were no differences, however, for number of seeds pod⁻¹. Genotypes also differed significantly in all characters, except number of seeds pod⁻¹ (Table 2).

Table 2. ANOVA for the performance of faba bean varieties at Ankober combined over years (2007 and 2008) (mean squares).

Character	Year (1)	Variety (14)	Variety x Year (14)	Error (55)
Plant height (cm)	12343.32**	142.81**	47.67ns	36.63
No. of pods per plant	1982.02**	78.87**	29.78ns	16.09
No. of seeds per pod	0.05ns	0.14ns	0.302ns	0.21
100 seed weight (cm)	199.55**	647.78**	39.16**	12.19
Biomass yield (kg ha ⁻¹)	418778984.7**	5423883.5**	1552123ns	1988018
Seed yield (kg ha ⁻¹)	63184 374.5**	1 338 796.3**	211548.4ns	369188.2

*, ** and ns denote significant differences at $p \leq 0.05$, $p \leq 0.01$, and non significant difference, respectively.

Numbers in parenthesis represent degree of freedom.

Genotype x Year interaction effects were not significant for all characters, except for 100 seed weight indicating the uniformity of the performance of genotypes over years (Table 2).

Significantly taller plant heights were recorded for Degaga, Moti, Gebelecho, Holeta-2, CS-20-Dk and Walki (Table 3). Pods per plant was significantly higher for Dagim, Local variety, Selale, Kasim, Wayu, Degaga, NC-58, Mesay and Lallo (Table 3). Gebelecho and Moti had significantly higher seed size (Table 3). Significantly higher seed yields were recorded for Gebelecho, Degaga, Moti, Bulga-70 and Walki (Table 3). The 100 seed weight advantage of these two varieties over Ankober local was 73.27%, and 34.45%, respectively. In addition, these varieties provided the highest biomass yield as compared to Ankober local.

Table 3. Seed yield and other agronomic characters of faba bean varieties evaluated at Ankober, averaged over 2007 and 2008.

Varieties	Plant height (cm)	Pods plant ⁻¹	Seeds pod ⁻¹	100 seed weight (g)	Biomass yield (kg ha ⁻¹)	Seed yield (kg ha ⁻¹)
Gebelecho	106.7abcd	14.33e	2.00	64.42a	11119.8a	4536.9a
Degaga	113.4a	21.00abc	2.50	43.41cd	10244.8abc	4358.5ab
Moti	113.5a	14.67de	2.50	62.87a	10854.2ab	4351.4ab
Selale Kasim	104.7bcd	25.00a	2.17	33.73fg	9692.7abc	3695.1bc
Wayu	111.8ab	25.00a	2.00	34.07fg	9875.0abc	3657.6bc
NC-58	104.7bcd	22.83abc	2.00	37.96ef	9406.3abc	3655.9bc
Mesay	104.4bcd	21.50abc	1.83	40.86de	9395.9abc	3505.0c
Tesfa	100.3cd	18.00cde	1.83	36.64ef	7056.5d	2483.1d
Dagim	98.6d	25.17a	2.33	30.28g	8687.5dc	3379.7c
Holeta-2	107.8abc	18.00cde	2.33	46.64bc	9901.1abc	3630.6bc
CS-20-Dk	109.3ab	19.83abcd	2.00	50.26b	9687.5abc	3669.4bc
Bulga-70	104.1bcd	17.50cde	2.17	44.05cd	8916.7bc	3730.0abc
Lallo	104.4bcd	24.33ab	1.83	31.59g	9062.5bc	3465.4c
Local var.	100.4cd	25.00a	2.00	37.18ef	8887.5bc	3863.1abc
Walki	106.1abcd	19.17bcde	2.17	49.99b	11130.2a	4450.2ab
Mean	106.06	20.76	2.11	42.5	9640.65	3780.51
CV (%)	5.71	19.32	21.68	8.12	14.63	16.07

Means followed by a common letter within a column are not significantly different with DMRT at 5%.

Seed yield and seed size are economic traits with the first and the second priority as prime objectives of the Ethiopian faba bean breeding program (Asfaw *et al.*, 1994b). Therefore considering the importance of diversifying varieties to avoid the risk of relying only on one variety (local variety) and based on seed yield, 100 seed weight and biomass yield as the major selection criteria, respectively Gebelecho and Walki are recommended for production on the well drained brown soils of Ankober and similar environments.

Acknowledgement

We would like to thank the Amhara Regional Agricultural Research Institute (ARARI) for financing this research project. Also we would like to thank the Debre Birhan Agricultural Research Center (DBARC) for the support provided during executing the experiment.

References

- Asfaw Tilaye, Geletu Bejiga and Alem Berhe. 1994a. Role of Cool-season Food Legumes and their production constraints in Ethiopian Agriculture. Pp. 3-18. In Asfaw Tilaye, Geletu Bejiga, M.C. Saxena, and M.B. Solh (eds.). 1994. Cool-season food Legumes of Ethiopia. Proceeding of the first national cool-season food legumes review conference, 16-20 December 1993, Addis Ababa, Ethiopia. ICARDA/IAR. ICARDA, Syria.
- Asfaw Tilaye, Tesfaye Getachew and Beyene Demtsu. 1994b. Genetics and breeding of faba bean. Pp.97-121. In Asfaw Tilaye, Geletu Bejiga, M.C. Saxena, and M.B. Solh (eds.). 1994. Cool-season food Legumes of Ethiopia. Proceeding of the first national cool-season food legumes review conference, 16-20 December 1993, Addis Ababa, Ethiopia. ICARDA/IAR. ICARDA, Syria.
- CSA (Central Statistical Authority). 2007. Agricultural sample survey 2007/2008 (2000 E.C), Volume I. Report on area and production of crops (Private peasant holdings, Meher season), Addis Ababa, Statistical Bulletin 417.
- Gemechu Keneni, Mussa Jarso and Tezera wolabu. 2006. Faba Bean (*Vicia faba* L.) Genetics and Breeding Research in Ethiopia: A Review .pp. 42-52, In: Kemal

- Ali, Gemechu Keneni, Seid Ahmed, R. Malhotra, S. Beniwal, K. Makkouk and M.H. Halila (eds.). Food and forage Legumes of Ethiopian: Progress and prospects. Proceedings of a workshop on food and forage Legumes.22-26 Sept. 2003, Addis Ababa, Ethiopia. ICARDA, Aleppo, Syria. ISBN 92-9127-185-4. P351.
- Gezahegn Ayele and Dawit Alemu. 2006. Marketing of pulses in Ethiopia. pp. 346-351. In Kemal Ali, Gemechu Keneni, Seid Ahmed, R. Malhotra, S. Beniwal, K. Makkouk and M.H. Halila (eds.). Food and forage legumes of Ethiopia: Progress and prospects. Proceedings of a Workshop on Food and Forage Legumes. 22-26 Sept 2003, Addis Ababa, Ethiopia. ICARDA, Aleppo, Syria. ISBN 92-9127-185-4. 351p.
- Gomez, K.A. and Gomez, A.A. 1984. Statistical Procedures for Agricultural Research.2nd ed. Johan Wiley and Sons Inc, N.Y.
- MARD (Ministry of Agriculture and Rural Development). 2008. Animal and Plant health Regulatory Directorate. Crop Variety Registration, Issue No. 11, Addis Ababa, Ethiopia.
- MARD (Ministry of Agriculture and Rural Development). 2006. Crop Development Department Crop Variety Registration, Issue No. 9, Addis Ababa, Ethiopia.
- National Agricultural Input Authority. 2002. Crop Variety Register Issue No.5.Addis Ababa Ethiopia.
- NAIA (National Agricultural Input Authority). 2001. Crop Variety Register Issue No.4.Addis Ababa Ethiopia.
- NAIA (National Agricultural Input Authority). 1998. Crop Variety Register Issue No.1.Addis Ababa Ethiopia.
- Nwokolo, E.1996. The need to increase consumption Chapman and Hall of Pulses in the feed from legumes and oilseeds. London.
- SAS Institute. 2004. SAS /STAT Guide for personal computers, version 9.1 editions. SAS Institute Inc., Cary, NC, USA.
- Yohannes Degago. 2000. Faba bean (*Vicia faba*) in Ethiopia. Institute of biodiversity conservation and Research. Addis Ababa.

Faba bean (*Vicia faba* L.) variety evaluation in Wag-himra and Lasta areas

¹Temesgen Alene and Aemiro Bezabih

¹Email:temesgenalene11@gmail.com

Sekota Dry land Agricultural Research Centre, P.O. Box 62 Sekota

Abstract

Faba bean is the second most important pulse crop next to field pea in Wag-himera and Lasta areas. However, its productivity is not more than 500 kg ha⁻¹. Therefore, evaluation of seven nationally released faba bean varieties against the local check was conducted in RCBD with three replications for two consecutive years at three locations (Dahna, Sayida and Lalibela) with the objective of identifying adaptable and high yielding varieties. Thus, based on the results of analysis of variance (ANOVA), AMMI analysis and farmers' selection criteria Mesay and Gebelecho varieties that gave the respective seed yield of 1956 and 1574 kg ha⁻¹ were recommend for production in Dahana, Lalibela, Sayida and similar areas.

Key words: Faba bean, variety.

Introduction

Faba bean (*Vicia faba* L.) is one of the major pulse crops grown in the highlands (1800-3000 m a.s.l.) of Ethiopia. It is believed that the crop was probably brought to Ethiopia from Middle East through Egypt (Yohannes, 2000) around the 5th millennium B.C., immediately after domestication (Asfaw *et al.*, 1994). Ethiopia is now considered as one of the centers of secondary diversity for faba bean (Yohannes, 2000). The crop is grown in several regions of the country with annual rainfall of 700-1000 mm. It is a crop of manifold merits in the economic lives of the farming communities in the highlands of Ethiopia: serves as a source of food and feed with a valuable and cheap source of protein; plays a significant role in soil fertility restoration as a suitable rotation crop that fixes atmospheric nitrogen; and a good source of cash to the farmers, and generates foreign currency to the country. Despite its importance, however, the productivity of the crop is far below its potential due to several yield reducing factors. The inherent low-yielding potential of the indigenous cultivars is among the most important production constraints (Asfaw *et al.*, 1994; Yohannes, 2000). Moreover, diseases like chocolate spot (*Botrytis fabae*), rust (*Uromyces viciae-fabae*) and root rot (*Fusarium solani*), and

abiotic stresses like water logging are important production constraints (Asfaw *et al.*, 1994; Dereje and Tesfaye, 1994).

Even though faba bean is the second most important pulse crop next to field pea in Wag-himera and Lasta areas, its productivity, 0.5 t ha⁻¹ (WADO, unpublished), has been by far lower than the national average, 1.15 t ha⁻¹ (CSA, 2006). The wide spread use of low yielding local cultivars by farmers is one of the most important factors accounting to the low productivity. This study was, therefore, conducted with the objective of identifying adaptable and relatively high yielding varieties for the Wag-himra and Lasta area.

Materials and methods

Study area

This study was conducted at Dahana, Sayida and Lalibela with the altitude of 2000 to 2100 m above sea level, and soil type of relatively light black soil. The testing locations fall in the SM2-5 (Tepid to cool sub-moist mountain plains) sub agro-ecology.

Experimental design and procedures

Seven nationally released varieties and a local check were evaluated in RCBD with three replications at each location in each year (2007 and 2008 main cropping season). The plot size was 2.4 m x 4 m with the spacing of 40 cm and 10 cm between rows and plants, respectively. Sowing was done in early July (1st week of Hamele) with the application of DAP fertilizer at the rate of 100 kg ha⁻¹. Hand weeding was done three times. Data were collected on days to flowering, days to maturity, plant height, number of pods per plant, number of seeds per plant, 100 seed weight and seed yield. Yield was estimated from a net plot area of 6.4 m². During the time of maturity in 2008 cropping season, a group of 20-30 farmers evaluated the performance of each variety at Dahana, Sayida and Lalibela. They evaluated the performance of the varieties according to their selection criteria which are yield potential, earliness, pod load, pod size, pod length and stand vigor.

Analysis of variance (ANOVA) was done using SAS software, and mean differences were tested by using Least Significant Difference (LSD). Homogeneity of error variances was tested prior to combined analysis over location in each year as well as over locations and years. In combined analysis, locations and years were treated as random factors while varieties were fixed (Peterson, 1994). Thus, the pooled error was used to test the effects of locations and years. The variety by location by year interaction was tested against the pooled error and it was used as an error term to test the variety by location and variety by year interactions, if it was found to be significant. The varieties (fixed factors) were tested against either the variety by year interaction or variety by location interaction, if either of these two were found to be significant using the variety by location by year interaction as an error term. The AMMI analysis was done for seed yield using Agro Base and Crop Stat software programs to test the stability of varieties across the test locations.

Results and discussion

Mesay followed by Lalo, Dagm, and Gebelcho gave higher seed yields of 1956, 1735, 1588 and 1574 kg ha⁻¹, respectively compared to the other varieties (Table 1).

Table 1. Seed yield (kg ha⁻¹) of faba bean varieties across three locations and two years.

Variety	2007			2008			Over all mean
	Dahana	Lalibela	Sayida	Dahana	Lalibela	Sayida	
CS-20-DK	1666.20 ³	2241.70	1002.10	1589.20 ³	1065.10	1716.20 ¹	1546.75
Moti	1249.50	1193.39	1333.30	1663.00 ²	1050.50	1618.90 ³	1351.44
Gebelcho	1658.40	2180.50	1709.10 ²	1285.30	1765.50	847.40	1574.36
Mesay	1960.00 ¹	2934.60 ¹	1111.40	1944.00 ¹	2089.40 ³	1694.80 ²	1955.71
Dagm	1271.70	2267.20 ²	987.10	1004.90	2591.70 ²	1404.70	1587.88
Lalo	1315.10	2246.90 ³	1709.50 ¹	1288.70	2682.80 ¹	1164.30	1734.56
Degaga	1325.50	1620.70	1617.30 ³	1485.60	1431.90	1432.80	1485.63
Local	1723.80 ²	1928.40	967.30	1050.50	1994.40	1132.60	1466.15
Mean	1521.29	2076.66	1304.64	1413.91	1833.91	1376.46	
LSD (0.05)	249.59	674.77	246.32	371.50	249.43	328.18	
CV (%)	9.37	9.90	10.78	15.00	7.77	13.61	

*^{1,2,3} Rank of varieties at each location.

The respective seed yield advantage of these varieties over the local check was about 33, 18, 8 and 6%. The yield performance of these varieties in the central highland areas of Ethiopia was reported to be 2-5 t ha⁻¹ on research station and 1.5-4.5 t ha⁻¹ on farmers' fields. However, the yield performance range of the varieties Mesay (1.1-2.9 t ha⁻¹), Gebelcho (0.8-2.1 t ha⁻¹), CS-20-DK (1.0-2.2 t ha⁻¹), Lalo (1.2-2.9 t ha⁻¹) and Degaga (1.3-1.6 t ha⁻¹) in the current environments is far below their potentials. This clearly indicated the yield penalty due to moisture deficit stress in Wag-himra and Lasta areas.

Hundred seed weight of Gebelecho in the three locations was the highest (52-77 g), closely followed by Moti with hundred seed weight of 51-73 g (Table 2). Gebelecho and Moti had significantly ($p < 0.05$) the highest seed size compared to the other varieties. The highest yielding variety, Mesay, with hundred seed weight of 41-47 g is the second best variety in terms of seed size. Hundred seed weight of the local variety (32-36 g) was higher than that of Lalo, which had the lowest seed weight of 30-32 g.

Table 2. Hundred seed weight (g) of faba bean varieties for each location as averaged over two years.

Varieties	Dahana	Lalibela	Sayida
Cs-20-Dk	44.90 ^{B*}	46.85 ^C	47.32 ^{BC}
Moti	72.50 ^A	71.48 ^B	51.28 ^{BA}
Gebelcho	71.07 ^A	77.07 ^A	52.07 ^A
Mesay	46.87 ^B	46.68 ^C	41.10 ^D
Dagm	32.83 ^C	30.08 ^{ED}	40.42 ^{DE}
Lalo	30.67 ^C	29.50 ^E	32.32 ^F
Degaga	47.25 ^B	45.48 ^C	44.50 ^{DC}
Local	34.00 ^C	32.08 ^D	35.82 ^{FE}
Mean	47.51	47.40	43.10
CV (%)	6.77	3.86	9.09

*Means followed by the same letters in a column are not significantly different at $P \leq 0.05$.

Varieties had significantly different ($p < 0.05$) number of pods per plant (data not shown). Gebelecho had the lowest (7-10) and Lalo the highest (15-19) pods per plant, closely followed by Degaga with 13-16 pods per plant. The highest yielding variety, Mesay, had 8-14 pods per plant. There was no appreciable difference among varieties in number of seeds per pod where almost all varieties had 3 seeds per pod, but the local

variety had 2 in few instances (data not shown). There was no big difference among varieties in terms of maturity (data not shown). The only big difference between the late maturing Gebelecho and the early maturing local variety was about 5 days at Dahana; otherwise, the difference among varieties in other locations was at most about 2 days.

Similarly, farmers have also evaluated the performance of the varieties based on yield potential, pod load, pod size, earliness, pod length, and stand vigor in the year 2008. Farmers selected Moti and Dagaga at Dahana; Gebelcho, Mesay and CS-20-DK at Sayida; and Gebelcho, CS-20-DK and Lalo at Lalibela.

The overall combined analysis of variance over the three locations and two years revealed significant difference in main effects of locations and years for all characters considered (Table 3). The main effects of varieties showed significant difference for all the characters, except for number of pods per plant, number of seeds per pod and seed yield. The variety by location interaction and variety by year interaction was not significant for all the characters, except a significant variety by year interaction for number of seeds per pod. The variety by year by location interaction was significant for all characters, except plant height (Table 3). This indicated that the tested varieties showed inconsistent performance over locations and years for most of the characters studied. Therefore, AMMI analysis was done to test the stability of the varieties.

Table 3. Mean square (MS) values of seed yield and other agronomic characters of faba bean varieties for the combined analysis of variance over locations (Dahana, Lalibela and Sayida) and years (2007 & 2008).

Source	df	Days to flowering	Days to maturity	Plant height	No. pods plant ⁻¹	No. seeds pod ⁻¹	100 seed weight	Seed yield
L	2	162.97**	1530.51**	11569.84**	262.31**	0.58**	303.62**	5055065.14**
Y	1	98.34**	132.25**	2096.88**	426.77**	0.15**	105.40**	309811.27**
V	7	30.27*	16.13*	480.83**	130.20 ^{NS}	0.35 ^{NS}	3353.72**	616788.74 ^{NS}
YxL	2	2110.67**	342.27**	8974.62**	474.38**	1.22**	352.26**	298766.84**
VxL	14	5.37 ^{NS}	6.00 ^{NS}	173.69 ^{NS}	22.01 ^{NS}	0.08 ^{NS}	266.91 ^{NS}	697127.55 ^{NS}
VxY	7	4.09 ^{NS}	9.65 ^{NS}	100.77 ^{NS}	38.78 ^{NS}	0.17**	85.39 ^{NS}	233209.62 ^{NS}
VxYxL	14	10.73**	4.72**	198.07 ^{NS}	50.31**	0.05**	124.81**	429419.82**
Error	84	1.20	1.96	120.41	8.98	0.14	9.68	30460.24

L= Location, Y= Year, V= Variety, Y x L = Year by location interaction, V x L = Variety by location interaction, V x Y= Variety by year interaction, V x Y x L=Variety by year by location interaction, **, * Significant at 1% and 5% respectively; NS= Non-significant.

The AMMI analysis of variance (Table 4) for seed yield of the 8 varieties evaluated at the 6 environments showed that 29.95% and 11.73% of the total variation was attributed to the respective environmental and genotypic main effects and 47.30% was due to genotype by environment interaction (GEI). Significant MS of environment indicated that the environments were diverse, with large difference among environmental means causing most of the variation in seed yield. The first interaction principal component axis (IPCA1) captured 56.89% of the interaction sum of squares. The second interaction principal component axis (IPCA2) explained a further 26.38% of the GEI sum of squares. The mean square for IPCA1 and IPCA2 were significant at $p < 0.01$ and cumulatively contributed to 83.27% of the total GEI.

Table 4. Additive main effects and multiplicative interaction (AMMI) analysis of variance for seed yield of faba bean varieties across environments.

Source	df	SS	MS	Explained (%)
Environments	5	11020250.00	2204050.00 ^{**}	29.95
Reps within Env.	12	1498624.00	124885.33 ^{**}	4.07
Genotypes	7	4316993.75	616713.39 ^{NS}	11.73
Gen. x Env.	35	17406472.00	497327.77 ^{**}	47.30
IPCA 1	11	9902158.93	900196.27 ^{**}	56.89
IPCA 2	9	4591921.84	510213.54 ^{**}	26.38
Residual	84	2558654.00	30460.17	
Total	143	36800993.75		

*Grand mean=1587.79; CV= 10.99; R-square = 0.93; NS = non significant and ** = significant at $p < 0.01$.*

The association between genotypes and environments can be clearly seen by plotting both the genotypes and the environments on the same graph. Those genotypes and environments located at the right side of the grand mean are considered to be high yielding genotypes and environments while their corresponding located at the left side of the grand mean are low yielding. The IPCA scores of genotypes in the AMMI analysis are an indication of the stability of adaptation over environments (Gauch and Zobel, 1996; Alberts, 2004). The greater the IPCA scores, the more specific adapted is a genotype to certain environments. The more the IPCA scores approximate to zero, the more stable or adapted the genotype is over all the environments sampled.

The most stable genotype based on IPCA1 scores were Mesay (d) and Gebelcho (c) (Figure 1). Mesay (d) and Lalo (f) were high yielding genotypes located at the right side of the grand mean, while all the rest of the varieties were low yielding which are located on the left side of the grand mean. Lalo (f) was unstable genotype adapted to high yielding environments (Lalibela). Moti (b), CS-20-DK (a), Dagm (e) and Degaga (g) were unstable and adapted to low yielding environments of Dahana and Sayida.

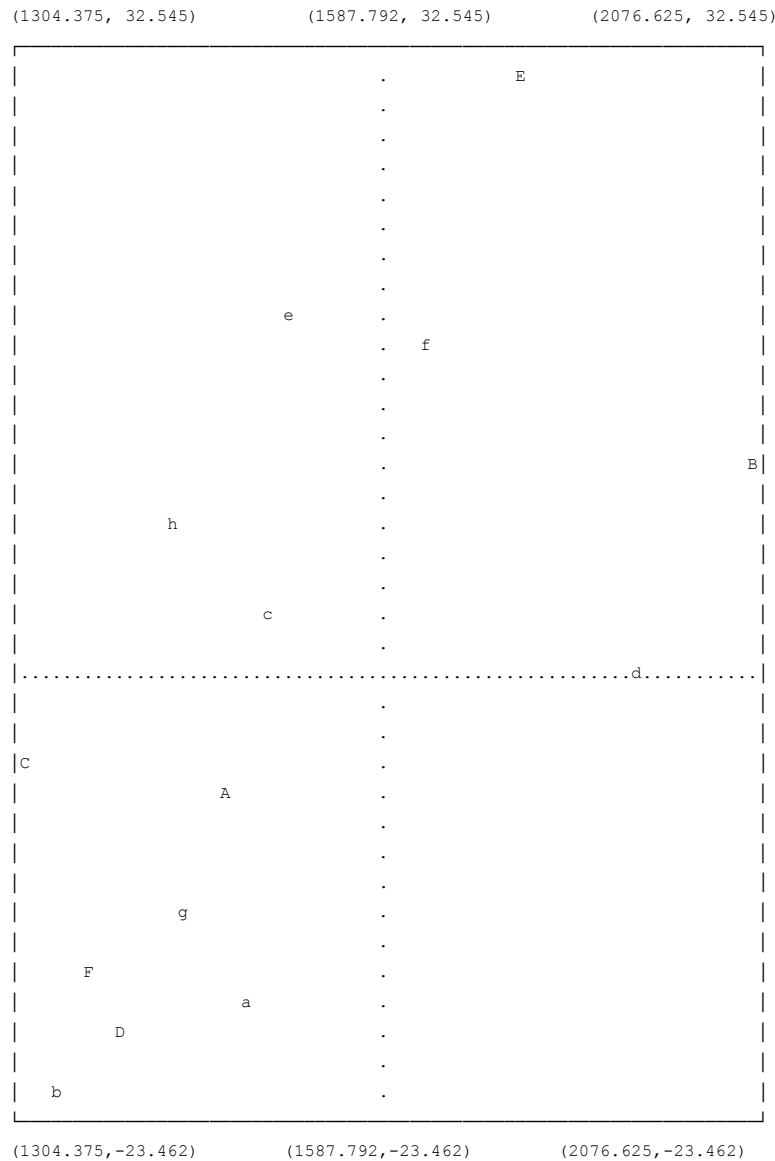

Figure 1. AMMI biplot of main effects and interactions for seed yield
 Where, a= Cs-20-Dk, b= Moti, c= Gebelcho, d=Mesay, e= Dagm, f=Lalo, g=Degaga, h=Local, A=Dahana in 2007, B=Lalibela in 2007, C=Sayida in 2007, D=Dahana in 2008, E=Lalibela in 2008 and F=Sayida in 2008.

IPCA2 scores also play a significant role (26.38%) in explaining genotype by environment interaction. Thus, the IPCA1 scores were plotted against IPCA2 scores to further explore adaptation (Figure 2). Gebelcho (c) was the most stable followed by the local variety (h) and Mesay (d). Dagm (e) and Lalo (f) for Lalibela area; Moti (b) and Degaga (g) for Dahana area, and CS-20-DK for Sayida area were specifically adapted genotypes.

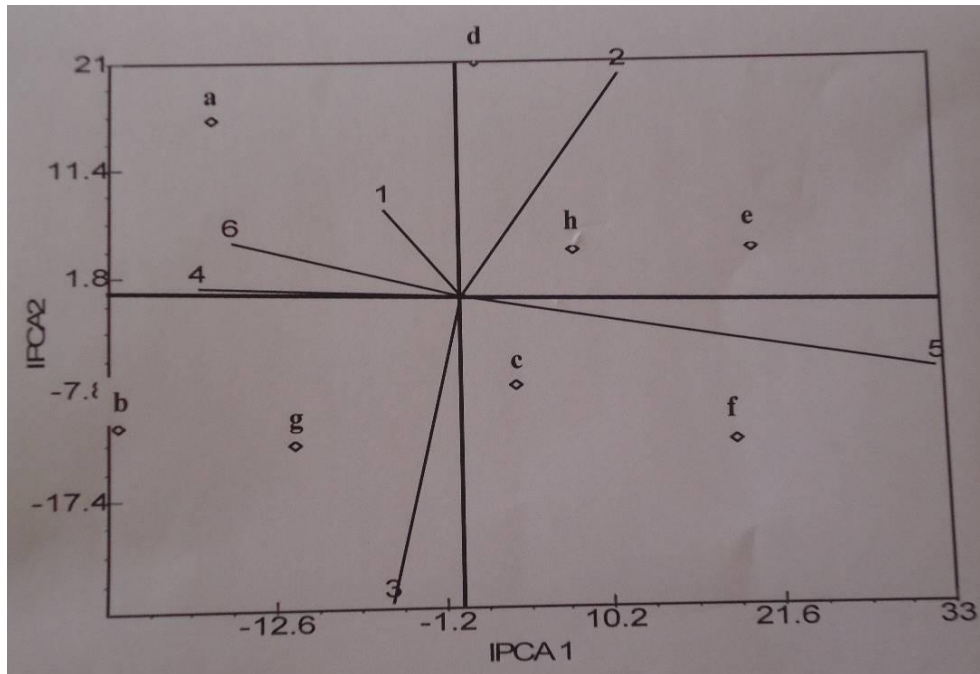

Figure 2. Interaction biplot for the AMMI2 model, for seed yield.

Where, a= Cs-20-Dk, b= Moti, c= Gebelcho, d=Mesay, e= Dagm, f=Lalo, g=Degaga, h=Local, 1=Dahana in 2007, 2=Lalibela in 2007, 3=Sayida in 2007, 4=Dahana in 2008, 5=Lalibela in 2008 and 6=Sayida in 2008

The AMMI model showed patterns and relationships of genotypes and environments successfully. The varieties best adapted to all of the environments were Mesay (d) and Gebelcho (c). The rest of the varieties were unstable, adapted to either high or low yielding environments. This can be justified by the typical feature of moisture stressed areas which is characterized by fluctuation of climatic factors over seasons and wide variation among localities. This is in agreement with Alberts (2004) who reported that factors such as rainfall, temperature, soil and pest incidence can result in conditions unique to each year-location combination and that the genotypes respond differently to

these conditions. Thus, Dahana and Sayida were low yielding environments, while Lalibela was high yielding.

AMMI Stability Value (ASV) based on the AMMI model's IPCA1 and IPCA2 scores for each genotype was also computed (Purchase, 1997) and presented in Table 5. ASV is the distance from the coordinate point to the origin in a two dimensional scattergram of IPCA1 scores against IPCA2 scores. The larger the IPCA scores, either negative or positive, the more specifically adapted genotype is to a certain environments; the smaller the IPCA scores, the more stable the genotype is to the overall environments studied. Thus, based on ASV Gebelcho, local variety and Mesay that scored the lowest AVS were the most stable over the environments (Table 5). However, Lalo, Dagm and Moti, which had the highest ASVs, were unstable varieties over the testing environments.

Table 5. IPCA1 score, IPCA2 score and AMMI Stability Value (ASV) of faba bean varieties tested across three locations and two cropping seasons.

Variety	IPCA1	IPCA2	AMMI Stability value (ASV)
Cs-20-Dk	-17.03	15.82	39.99
Moti	-23.47	-11.06	51.80
Gebelcho	3.82	-7.95	11.45
Mesay	1.22	20.94	21.11
Dagm	20.16	3.91	43.66
Lalo	18.88	-12.93	42.72
Degaga	-11.55	-12.79	28.00
Local	7.97	4.05	17.65

Conclusion

The combined analysis of variance over the three locations and two years revealed that there was significant variety by year by location interaction for most of the characters, indicating that the tested varieties showed inconsistent performance over locations and years. Mesay and Gebelecho varieties were selected by AMMI analysis for their higher yield and relatively stable performance across locations and years. Gebelecho was also positively selected by farmers in all test locations, while Mesay was selected in one location. Therefore, Mesay, in addition to Gebelecho, was selected for its highest seed

yield across locations and years, and its bigger seed size than the local variety. Seed size of Gebelecho was by far bigger than that of Mesay. Thus, Gebelecho and Mesay varieties are recommended for production in Dahana, Lalibela, Sayida and similar areas.

References

- Alberts, M.J.A. 2004. Comparison of statistical methods to describe genotype x environment interaction and yield stability in multi-location maize trials. M.Sc. Thesis, University of the Free State.
- Asfaw Tilaye, Tesfaye Getachew and Beyene Demtsu. 1994. Genetics and breeding of faba bean. pp. 97-121. Cool-season food legumes of Ethiopia. Proceeding of fist national cool-season food legumes review conference 16-20 December 1993, Addis Ababa, Ethiopia.
- CSA (Central Statistical Authority). 2006. Agricultural sample survey, 2005/2006. Area and production of crops. Statistical Bulletin, Volume I, Addis Ababa.
- Dereje Gorfu and Tesfaye Beshir. 1994. Faba bean disease in Ethiopia. pp. 328-345. Cool- season food legumes of Ethiopia. Proceeding of fist national cool-season food legumes review conference 16-20 December 1993, Addis Ababa, Ethiopia.
- Gauch, H.G. and Zobel, R.W. 1996. AMMI Analysis of Yield Trials. Genotype-by-Environment Interaction, Kang, M.S. and H.G. Gauch (Eds.). Boca Raton: CRC, New York, USA. pp: 85-122.
- Petersen, R.G. 1994. Agricultural field experiments: Design and Analysis. Marcel Dekker, Inc., New York, 409p.
- Purchase, J.L. 1997. Parametric analysis to describe GxE interaction and yield stability in winter wheat. PhD. Thesis, Department of Agronomy, Faculty of Agriculture, University of the orange Free State, Bloemfontein, South Africa.
- Yohannes Degago. 2000. Faba bean (*Vicia faba*) in Ethiopia. Institute of Biodiversity Conservation Research (IBCR). Addis Ababa, Ethiopia.

Enzyme linked immune-sorbent assay based survey on bacterial wilt and viral diseases of potato in western Amhara Region

¹Ermias Abate, ²Berhanu Bekele, ³Alemayhu Asefa

¹Amhara Region Agricultural Research Institute, P.O. Box 527, Bahir Dar, Ethiopia.

²Ethiopian Institute of Agricultural Research (EIAR), Plant Protection Research Centre (PPRC), P. O. Box 37, Ambo, Ethiopia

³Ethiopian Institute of Agricultural Research (EIAR), Holeta Agricultural Research Centre, P. O. Box 2003, Addis Ababa, Ethiopia

Abstract

In the Amhara region, spread of improved potato varieties is challenged by incidence of wilt and viral diseases. Nonetheless, no attempt has, so far, been made to establish their identity through laboratory procedures. In order to bridge this gap, a survey was conducted on potato viral and bacterial wilt diseases from July 31 to August 15, 2008 in selected potato growing areas of Western Amhara region. A total of 146 composite leaf samples were collected and tested for six viruses: PLRV, PVA, PVM, PVS, PVX and PVY using DAS-ELISA. Similarly, a total of 62 tuber and 30 stem samples were collected mainly from released potato varieties in farmers' fields and tested for bacterial wilt pathogen, *Ralstonia solanacearum* (Rs) by NCM-ELISA. Results showed that all the viruses but PVA showed positive reaction. PVS was the most prevalent viral disease followed by PVX, PVM, PLRV and PVY in that order. Likewise, most of the wilted plants checked for bacterial wilt were found positive indicating that the pathogen is a likely cause of wilting. In addition, healthy samples tested by the enrichment procedure appeared positive for some of the localities. Generally, the existence of these diseases means that they can incur very high yield loss on potato. Especially, control of bacterial wilt is very difficult and the yield loss is unbearable. The pathogen can stay in soil for several years and can be transmitted by infected seed, irrigation water and farm implements. It can also restrict production of several other crops related to potato. Hence, all possible measures have to be taken in order to limit expansion of these diseases.

Key words: Bacterial wilt, DAS-ELISA, NCM-ELISA, potato, viral disease.

Introduction

Potato (*Solanum tuberosum* L.) is one of the widely produced and consumed horticultural crops in the western Amhara Region. Potato production in the region reaches as high as 70, 0000 ha of which 95% comes in the western part of the region (CSA, 2003). Amhara Region contributes over one third of the total area allotted to potato production in Ethiopia. About 600,000 rural households are engaged in potato

production in the region. Its production is mainly restricted to the highlands where there is limited crop choice, and is one of the major food security crops. Nevertheless, the average productivity of potato in the region is much lower than the national (7.2 t ha^{-1}) and African (10.8 t ha^{-1}) average (FAO, 2008). However, research results in the region indicated that productivity of 30 t ha^{-1} is achievable on research plots using quality seeds of improved varieties and improved production packages.

The existing potato seed system is characterized by traditional informal multiplication and distribution of seed tubers by small scale subsistent farmers. Consequently, poor yielding local potato cultivars that are highly susceptible to diseases dominate the system. Efforts are, however, underway to multiply and distribute improved potato varieties. Nonetheless, these attempts are increasingly challenged by incidence of wilt and viral diseases. Indeed, potato diseases and lack of quality seed tubers are two of the major potato production constraints in the area. However, there has not been any systematic scientific study made to establish the identity, incidence and distribution of potato diseases. Knowledge of identity, incidence and distribution of diseases could help to design timely and appropriate management strategies. This is particularly important in potato where because of its vegetative mode of propagation diseases can easily be transmitted through tubers and cause very high economic loss across wider area. In potato viral disease symptoms are often masked by the simultaneous occurrence of mosaics caused by potato virus X (PVX), potato virus Y (PVY) and potato virus S (PVS). This makes identification of viral diseases based only on symptom difficult (Fletcher *et al.*, 1996; Burrows and Zitter, 2005). On the other hand, bacterial wilt (brown rot) caused by *Ralstonia solanacearum* can stay latent without showing any symptom. This study was, therefore, undertaken to establish the identity, level of incidence and distribution of viral and bacterial wilt diseases of potato in the major production areas of western Amhara Region.

Materials and methods

Field visit and sample collection

An extensive potato viral and bacterial wilt diseases survey and sample collection was conducted from July 31 to August 15, 2008 in selected potato growing areas of four administrative zones of west Amhara Region (Figure 1; Table 1).

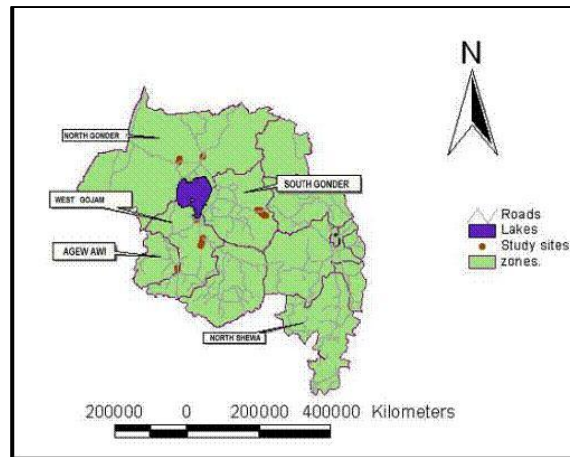

Figure 1. Map of Amhara Region with the four sampling zones. Sampling sites are marked with red dots.

Virus diseases: For typing viruses infecting potato, leaf samples with symptoms suggestive of virus infection were collected in the surveyed areas. From each field, one or more composite samples were collected depending on the type and diversity of symptoms encountered, with each composite sample tested being a mixture of 100 individual plant samples. A total of 146 composite samples were collected from 37 fields located at 16 sites, including experimental plots at Adet and Gonder Agricultural Research Centres (Table 1). Leaflets were collected from upper, middle and lower parts of the individual plants sampled. Sampling was done at a constant interval depending on the distribution of the crop in respective zones/locations surveyed. Simple random sampling of symptomatic plants was made by making a transverse walk across the field. Disease incidence was recorded visually as percent infection.

Bacterial wilt: Bacterial wilt field sampling was done following simple random sampling as outlined for the viral diseases. However, in this case, tuber and stem samples were collected.

Table 1. Potato samples collected and tested for potato viruses and bacterial wilt diseases from four zones of western Amhara Region.

Administrative Zones	Leaf samples			Tuber samples			Stem samples		
	Number of samples	Number of fields surveyed	Number of locations	Number of samples	Number of fields surveyed	Number of locations	Number of samples	Number of fields surveyed	Number of locations
West Gojjam	100	16	4	51	13	8	11	1	1
North Gonder	31	6	4	3	2	2	6	3	3
Awi	5	5	2	4	4	2	10	5	5
South Gonder	10	10	6	4	4	3	3	3	3
Total	146	37	16	62	23	15	30	12	12

Sampling was done mainly from released potato varieties in farmers' fields to determine the status of disease incidence and distribution. Accordingly, a total of 62 tuber and 30 stem samples were collected and tested from 15 and 12 locations in 23 and 12 fields, respectively (Table 1).

In addition, data on crop growth stage and variety, disease symptoms, diseases incidences (%), purpose of production (ware or seed), and altitude of each location and its corresponding geographical position (using geographical positioning system) were collected during potato field inspection. The collected leaf, tuber and stem samples were labelled, put in plastic bags, brought to laboratory and kept at 4-6 °C in refrigerator until processed for detection test of viruses and bacterial wilt pathogens.

Laboratory test

Virus diseases: Leaf samples were tested for six viruses, namely potato leaf roll virus (PLRV), potato virus A (PVA), potato virus M (PVM), potato virus S (PVS), potato virus X (PVX) and potato virus Y (PVY) using Double Antibody Sandwich-Enzyme Linked Immunosorbent Assay (DAS-ELISA) following the International Potato Centre (CIP) DAS-ELISA kit standard protocol described in CIP instruction manual (CIP, 2001). Batteries of six polyclonal antibodies developed against six viruses were used.

Bacterial wilt disease: Stem and tuber samples were tested for bacterial wilt pathogen, *Ralstonia solanacearum* (*Rs*), by Nitrocellulose Membrane-Enzyme Linked Immunosorbent Assay (NCM-ELISA). In addition to random samples taken to see latent infection, confirmatory work was also made for plants that showed wilt symptom to check whether it is caused by *Rs*. Sample preparation and serological test was done according to the procedures outlined in CIP NCM-ELISA instruction manual for detection of *Ralstonia solanacearum* in potato by using NCM-ELISA kit supplied by CIP serology laboratory at Lima, Peru. In order to increase the sensitivity and detect latently infected plants, an enrichment procedure was carried out before performing NCM-ELISA by incubating the tuber and stem extracts in semi selective broth.

Results and discussion

Viral and bacterial wilt diseases incidence in the field

The most commonly observed virus-like symptoms in potato were leaf curling, interveinal mosaic, mottling, reduced leaf size, leaf vein deepening and stunting. Disease incidence varied from none to 100% infection in different farms and variety evaluation plots. For instance, in a national variety trial (NVT) at Adet Agricultural Research Center (AARC), 100% incidence was recorded on variety *Guassa* used as standard check (Figure 2) and more than 50% incidence on *Gudenie* variety and the local check. Among test clones included in NVT, the highest incidence (85%) was recorded on CIP 395112.36. In a variety verification trial (VVT), disease incidence ranged from 25-70%. In a regional variety trial (RVT)-III, 100% infection was recorded on a clone “CIP 392640.516” and 80% infection on other two clones, CIP 391588.563 and CIP 392640.504. Some clones in the variety evaluation plots looked apparently free of any symptom. When seed increase plots of released potato varieties were visually evaluated, highest (> 90%) incidence was recorded on variety *Degemegn*.

In north Gonder zone, disease incidence of 10-15% was recorded on *Jalene* variety used for on-farm fertilizer trial by the Gonder Agricultural Research Center (GARC) at Chiliga. In the same location, 100% incidence was recorded on one of the clones included in RVT-III while lower incidences ranging between 2% and 30% were recorded on the rest of test clones. In RVT-I, highest and lowest incidences were 75% and 5%, respectively. Again, low disease incidence of between 5% and 10% was recorded on farmers' fields planted with improved varieties. Most plants were at flowering stage at the time of sampling which is an appropriate time for symptoms expression. In South Gonder zone, the most common symptoms were deepening of veins and interveinal mosaic. The latter was particularly more prevalent in farmers' fields planted with local potatoes.



Figure 2. Viral disease incidence on *Guassa* potato variety in germplasm evaluation plots.

With regard to bacterial wilt, most common symptoms were: wilting (Figure 3), browning of vascular tissue upon cutting and oozing milky fluid from the vascular ring of cross-sectional cut tubers. Bacterial wilt incidence of as high as 20-25% was recorded in localities surrounding Adet in Yilmana Densa district of West Gojjam Zone and some farms in Chiliga districts of North Gonder Zone.



Figure 3. Wilted symptomatic plants tested almost 100% positive for bacterial wilt of potato (*Ralstonias solanacearum*).

Viral diseases identity and incidence as determined by DAS ELISA

DAS-ELISA testing of symptomatic plants indicated that five out of the six viruses tested gave positive reaction (Table 2). Potato virus A was not detected in any of the samples tested. Potato virus YS (PVYS) was the most widely distributed viral disease followed by PVX, PVM and PLRV and PVY in that order.

Table 2. DAS-ELISA results of samples collected from the surveyed areas.

Zone	District	Sample Field	No of Samples	Virus Detected as % of the samples collected					
				PLRV	PVA	PVM	PVS	PVX	PVY
W. Gojjam	Adet	EF	71	60	0	53	84	56	28
		OSSE	10	20	0	10	40	20	20
		FF	5	20	0	0	80	0	0
		OFSE	9	33	0	11.1	55.5	22.2	11.1
Awi	Bahir Dar	ARARI	5	0	0	0	20	0	20
	Tilili/Kosober	OFSE	5	0	0	0	100	40	0
N. Gonder	Chilga	EF	27	48	0	59	59	22	0
		OFSE	4	0	0	25	100	0	0
S.Gonder	Tach Gaint	OFSE	2	0	0	0	50	100	0
		FF	5	0	0	0	60	100	0
	Lai Gaint	FF	3	0	0	0	66.6	66.6	0

EF = Experimental fields, OSSE = On farm seed increase, OSSE = On station seed increase, FF = Farmers ware potato field planted with local cultivars.

Potato virus S and PVX had also high incidence percentage as compared to the rest of the diseases. In most of the cases, simultaneous detection of two or more viruses was common particularly in experimental plots. Disease incidence appeared very high at Adet experimental station where 100% incidence was recorded for some of the varieties in variety evaluation fields. Similarly, all viruses but PVA were detected in on-station and on-farm seed increase fields at and in the vicinity of Adet.

In North Gonder Zone, all the five viruses that were tested positive at Adet experimental plots were detected from experimental plot samples at Chilga with 59% for PVS and PVM, 48% for PLRV and 22% for PVX. However, from the on-farm seed increase plots only PVS and PVM were detected with incidence levels of 100% and 25%, respectively. Out of five samples collected from on-farm seed increase plots at Kosober and Tilili areas, only PVS and PVX were detected. Potato virus S was identified from 100% of the samples and PVX was from 40% of the samples. In South Gonder, two (PVS and PVX) of the six viruses were detected on symptomatic leaf samples collected from 10 locations (7 in Tach Gaint and 3 in Lai Gaint), and all the tested samples were positive to either one or two of these viruses. Of the total samples, 6 (60%) were positive for PVS, while PVX was detected in all of the samples collected from 10 locations. Mixed infections of PVS and PVY were detected in 6 (60%) out of 10 samples. Most of the samples collected from farmers' fields cropped with local varieties in South Gonder indicated a wider distribution of PVS and PVX in the local potato production system. Simultaneous detection of viruses in the samples tested suggests that there is high yield loss or at least risk of high yield loss due to interaction of the different viral pathogens detected in the samples. Such phenomenon is substantiated by several workers. Cyperus and Bokx (2005) reported that concurrent occurrence of PVS and PVX causes much higher yield loss than their independent occurrence. Similarly, Burrows and Zitter (2005) reported heavier yield loss on co-occurrence of PVY and PVX or PVA. Simultaneous infection of potato plants by different viruses also hastens the rate of varietal degeneration manifested by a decrease in vigor, productivity and resistance to diseases of potato (Sangar *et al.*, 1988). According to Cyperus and Bokx (2005), simultaneous occurrence of PLRV and PVY are the most important cause of 'potato degeneration'. Besides, the study showed that some uncommon

seemingly viral infection symptoms (Figure 4) did not appear to have positive reaction which might indicate presence of other viral or viral like organisms that were not included in the testing kit.



Figure 4. Virus-like symptoms.

Generally, the study showed that viral incidence is higher on experimental plots as compared to farmers' fields (Table 2). This can be explained by the presence of susceptible clones in the test materials and/or because of high inoculums build up in the experimental stations or their facilities over time.

Bacterial wilt incidence and distribution as determined by NCM ELISA

Thirty one symptomatic samples (19 stem and 12 tubers) that showed wilting symptom were taken from on-farm seed increase plots planted to variety *Jalene* at Adet and tested for *Ralstonia solanacearum* infection by NCM-ELISA technique (Table 3). The result indicated that all the tuber samples and 86.6% of the stem samples tested positive to the pathogen. Similarly, all the stem samples collected from experimental plots at Chilga tested positive.

On the other hand, samples taken from tubers of wilted local cultivar at Adet tested negative for the pathogen suggesting that the causative agent might be something else. The finding suggested that *Ralstonia solanacearum* is the likely causative agent for potato plant wilting in the surveyed areas. Unfortunately, most of the sampled fields that tested positive were planted to improved varieties for seed production. These fields are managed by those who have no awareness about the disease and neither were they supervised by those who

have the expertise. This scenario signifies a very high risk that could be induced by such schemes. In addition, 50 tuber and 10 stem samples were randomly collected from non-symptomatic plants from fields planted to improved varieties for seed and local cultivars for ware purpose.

Table 3. Confirmatory test of symptomatic /wilted/ plants without enrichment procedure of NCM-ELISA.

Zone	District/Locality	Variety	Plant Part Sampled	No of samples	NCM-ELISA Positive (%)
W.Gojjam	Y/Densa - Goshiye	Gera	Tuber	9	66.6
	Y/Densa - Goshiye	Gera	Stem	15	86.6
	Y/Densa -Adet	Jalene	Tuber	2	100.0
	Y/Densa -Adet	Local	Tuber	1	0.0
N.Gonder	Chilga	Guassa	Stem	4	100.0

The NCM-ELISA test was run through the enrichment procedure (Figure 5) so that latent infection of small pathogen load can easily be detected. Positive (10^6 , 10^7 , 10^8) and negative controls from CIP were used for comparison. The result confirmed the existence of *Ralstonia solanacearum* in latently infected and healthy looking field sampled plants from Adet, Chilga and Injibara (Table 4). Also a sample collected from local potato cultivar field tested positive. The danger of latent infection is that the pathogen can be multiplied unnoticed and disseminated to wider area risking potato and other related species production. On the other hand, none of the samples collected from South Gonder tested positive for *Rs*.

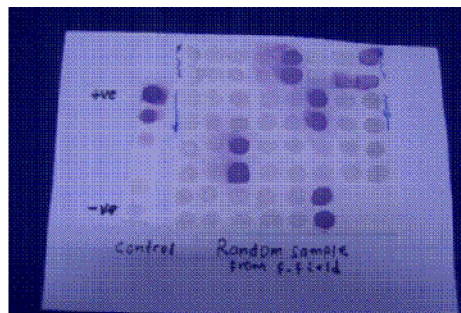

Figure 5. NCM ELISA (enrichment procedure) test result of samples collected from improved potato varieties grown for seed production.

Table 4. Test results of potato plants through the enrichment procedure of NCM-ELISA.

Zone	District/Locality	Variety	Type of field sampled	Plant part sampled	No of samples	NCM-ELISA positive (%)
W.Gojjam	Adet	Local Siquare	FF	tuber	2	0
		Jalene	OFSE	tuber	2	0
		Local Sisay	FF	tuber	1	0
		Zengena	OSSE	tuber	1	0
		Gera	OFSE	stem	5	40
		Gera	OFSE	tuber	30	20
Awi	Bahir Dar-ARARI	Zengena	OSSE	tuber	1	0
	Enjibara	Guassa	OSSE	tuber	1	0
		Jalene	OFSE	tuber	2	0
N.Gonder	Chilga	Local (Deme)	FF	tuber	1	0
		Local (Samuni)	FF	tuber	1	100
		Chilga local	FF	tuber	1	0
		Guassa	EF	stem	2	50
S.Gonder	Tach Gaint	Guassa	EF	tuber	2	50
		Local (Kara)	FF	tuber	1	0
		Jalene	OFSE	tuber	3	0
	Lai Gaint-Gob gob	Jalene	OFSE	stem	3	0
		Local	FF	tuber	1	0

EF = Experimental fields, OSSE = On farm seed increase, OSSE = On station seed increase, FF = Farmers ware potato field planted with local cultivars.

Conclusion and Recommendations

The study confirmed the existence of at least five viruses attacking potato in Western Amhara Region. Potato virus S appeared the most commonly detected and widely distributed followed by PVM, PLRV, PVX and PVY in that order. Potato virus A was not detected in any of the samples tested. In most of the cases, 2 or more viruses were simultaneously detected indicating their high potential to cause substantial yield loss. The use of DAS- and NCM-ELISA proved very powerful diagnostic tools to inspect potato planting materials prior to distribution to growers to ensure production of clean planting

materials. The level of viral disease incidence was higher on visual observation. However, this has not been reproduced in laboratory tests. This might indicate the presence of other pathogens with closer symptom to the identified ones which could not be confirmed in this study because of lack of kits. Alternatively, it can be a manifestation of some form of nutrient deficiency. The improved informal seed system judges the health of seed tubers based on physical symptomatic expression. This procedure is not valid for latent viral and bacterial diseases. Therefore, whenever there are doubts on the health standard of the plants testing incidence of important diseases should be carried out following appropriate pathological procedures.

Similarly, bacterial wilt was detected in tuber and stem samples collected from symptomatic (wilting) and apparently healthy looking plants, indicating the powerfulness of NCM-ELISA in detecting latent infection in healthy looking plants. Despite the relatively small number of samples analyzed, incidence of bacterial wilt is confirmed on substantial proportion of the samples collected across the surveyed areas. As there is no remedial for this disease, the high incidence of latent infection indicates the potential danger that potato production could face in the region unless appropriate precautionary measures are taken. Should bacterial wilt disease is effectively prevented strict adherence to preventive measures is essential. As the disease is mainly transmitted through seed, farm implements and irrigation water, awareness has to be created among various stakeholders in major potato growing areas of the region. Hence, imposing quarantine law, and potato seed movement restriction from location to location should be strictly implemented to minimize wide spread of the disease. Moreover, integrating the use of healthy planting materials with appropriate cultural practices such as crop rotation with non solanaceous crops should be sought and taught to farmers as economical, cost effective and safe control measures. Transport, marketing and utilization of seed tubers for table potato production should be supported by certificate. In addition, the regional plant health clinic laboratories have to frequently monitor incidence and distribution of selected diseases and provide information. In addition, monitoring populations of important potato disease vectors has to be made on areas specialized for seed potato production.

The regional research system has been and is striving to generate and supply improved potato technologies to farmers. Nonetheless, such efforts did not have the required support from laboratories in terms of pathogen testing and availing healthy starter planting material. Hence, the high disease incidence recorded in the germplasm evaluation plots should not be surprising. Since the research centres are the only source of planting material for improved varieties, high disease incidence in experimental plots implies the likelihood of disease incidence on farmers' plots is high. The high disease pressure in research plots can also hamper genetic expression of the genotypes and thereby lowers the chance of developing improved varieties by the research system. Therefore, it is imperative that the tissue culture laboratory of the Amhara Region Agricultural Research Institute be part and parcel of the research endeavor so as to furnish healthy starter planting material both for germplasm evaluation as well as seed production.

Acknowledgment

We would like to express our sincere and deepest gratitude to ARARI management body for their keen interest and unreserved support in the execution of the study. Our thanks also go to EIAR and PPRC management for their willingness to collaboratively undertake this activity.

References

- Burrows, M.A. and Zitter, T.A. 2005. Virus problems of Potatoes; Vegetable MD Online. USDA-ARS and Department of Plant Pathology, Cornell University, Ithaca. Accessed on 8/10/2008.
- CSA (Central Statistics Authority) (2003). Agriculture sample survey 2002/2003: Report on area and production for major crops. Statistical bulletin 200, CSA, Addis Abeba, Ethiopia.
- Cyperus, C. and Bokx, J.A. 2005. Virus Diseases. In: Mulder and Turkensteen, L.J. (eds) Potato Diseases. Aardappelwereld B.V. and NIVAP, Den Haag The Netherlands.

- FAO. 2008. Potato world: Production and consumption. International year of the potato 2008.
- Fletcher, J.D., Lewthwaite, S.L., Boddington, H.J., Nott, H.M. and Wood, R.J. 1996. Virus diseases survey of ware potato crops. *New Zealand Journal of Crop and Horticultural Science* 24: 7-12.
- CIP (International Potato Center). 2001. CIP DAS-ELISA kit for potato viruses detection: Instruction manual. Serology Laboratory, International Potato Center. Lima, Peru.
- Priou, S. 2001. CIP NCM-ELISA kit for the detection of *Ralstonia solanacearum* in potato: Instruction for use. International Potato Center (CIP), Lima, Peru.
- Sangar, R.B.S., Agrawal, H.O. and Nagaich, B.B. 1988. Studies on the translocation of potato viruses X and Y in potatoes. *Indian Phytopathology* 41: 327-331.

Split application of nitrogen fertilizer for lowland rice production on Vertisols of Fogera plain

Alemayehu Assefa, Tilahun Tadese, Minale Liben and Zelalem Tadese
Adet Agricultural Research Center, P.O.Box 8, Bahir Dar, Ethiopia

Abstract

Complete factorial combinations of two economically feasible nitrogen fertilizer rates (69/23 and 46/46 kg N/P₂O₅ ha⁻¹) and five levels of split nitrogen fertilizer application times (half at sowing + half at tillering representing the control; half at sowing + half at panicle initiation; one-third at sowing + two-third at tillering; one-third at sowing + two-third at panicle initiation; and one-third at sowing + one-third at tillering + one-third at panicle initiation) were compared in RCBD with three replications at four sites. The objective was to determine the optimum time of split nitrogen fertilizer application for improving productivity of lowland rice on Vertisols of Fogera plain. First and second order interactions of site-year environments, N rates and timing of N split applications did not significantly affected grain yield response of rice. The main effects of N rates also had no significant grain yield difference. But, the main effects of N split application times significantly ($p < 0.05$) affected grain yield. Split application of N at one-third at sowing and two-third at tillering stage was the highest yielding (4409 kg ha⁻¹) and is recommended for lowland rice production in the Vertisols of Fogera plain.

Key words: Nitrogen fertilizer, rice, split application.

Introduction

Rice (*Oryza sativa* L.) is an important food crop of the world. In Ethiopia, rice has become one of the most important crops where its production and area coverage have been increasing, especially in the Fogera plain (Tesfaye *et al.*, 2005). Research activities have been going on so as to improve productivity and production of rice in the Fogera plain. For instance, fertilizer rate recommendations of 69/23 and 46/46 kg N/P₂O₅ ha⁻¹ increased rice grain yield by 43 and 38%, respectively over the unfertilized treatment (Tilahun *et al.*, 2007) where rice was grown every year as monocrop. Experiences elsewhere also show that most crop plants recover only 25-35% of the nitrogen applied as fertilizers. Losses occur by ammonia volatilization, denitrification, immobilization to organic forms, leaching, and

runoff (Kissan-Kerala, 2007). Increasing the congruence between crop N demand and N supply improves N use efficiency in lowland rice (Cassman *et al.*, 1998). One of such options is split application of nitrogen fertilizer that was reported to show increased rice yield (Zaheen *et al.*, 2006). The increase in grain yield with increasing number of N splits might be due to increased nitrogen uptake efficiency and reduction in nitrogen losses (James and Stribbling, 1995). Generally, recommendations on number of N fertilizer splits depend on factors like rice variety, yield goal, total amount of nitrogen to be applied, soil type, climate and crop rotation (James and Stribbling, 1995). Thus, there are numerous reports that recommend different nitrogen fertilizer application splits for rice production. Charles (2003) recommended two splits application where the first split is applied at planting and the remaining at internodes elongation. Stevens *et al.* (2001) recommended three split applications at basal, at early-maximum tillering and at panicle initiation. Consuelo *et al.* (1996) also recommended that nitrogen fertilizer should be applied in four splits at basal, maximum tillering, panicle initiation and flowering. This study was, therefore, conducted to determine the optimum time of nitrogen fertilizer application to improve productivity of rice in the Fogera plain.

Materials and methods

The study area

This experiment was conducted on the Vertisols of the Fogera plain. Fogera plain belongs to the moist tepid to cool agro-ecological zone and to the tepid to cool moist plains sub agro-ecology (CEDEP, 1999). Fogera plain is located in the South Gondar Administrative Zone at an altitude of 1910 meter above sea level. The nine years (1998-2004, 2006 & 2007) mean annual rainfall in the area is 1317 mm. Based on the data from Addis Zemen meteorology station, which is at vicinity of experimentation area, four years (2004-2007) mean monthly maximum and minimum temperature is 29.8 °C and 9.4 °C, respectively. The soil textural class is 67% clay, 25% silt and 8% sand, with a soil pH of 5.8 (Yihenew, 2002). The annual rainfall distribution is indicated in Figure 1.

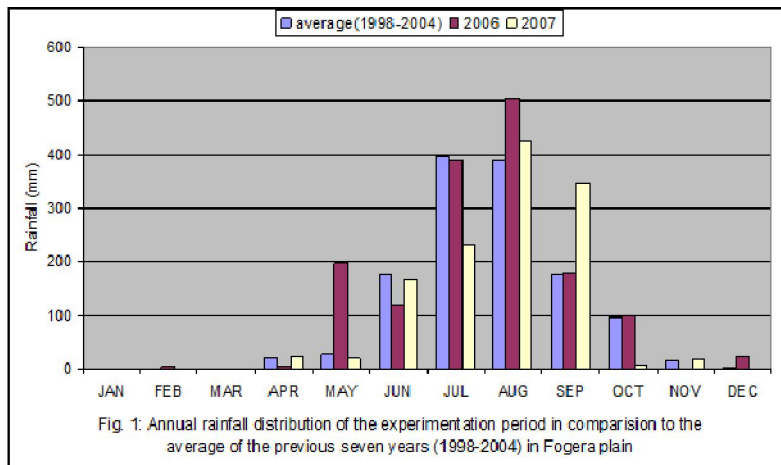

Experimental design and procedures

The experiment was conducted in four sites (one site in 2006 and three sites in 2007) under rainfed conditions. Complete factorial combinations of two economically feasible fertilizer rates (69/23 and 46/46 kg N/P₂O₅ ha⁻¹) and five splits of nitrogen fertilizer application times (half at sowing + half at tillering representing the control; half at sowing + half at panicle initiation; one-third at sowing + two-third at tillering; one-third at sowing + two-third at panicle initiation; and one-third at sowing + one-third at tillering + one-third at panicle initiation) were laid out in RCBD with three replications at each site. The gross and net plot sizes were 4 m x 3 m and 3 m x 2 m, respectively. All the phosphorus fertilizer rates were applied at sowing. Variety *X-Jigna* was broadcast sown at the seed rate of 100 kg ha⁻¹. Grain yield, fertile panicle number, thousand grain weight, and plant height data were subjected to analysis using SAS by considering the four site-year environments as random variable.

Results and discussion

The analysis of variance for individual sites indicated that significant grain yield differences in response to time of nitrogen application were observed only in two of the four sites (Table 1). Significant differences in response to nitrogen fertilizer rates and fertilizer by time of application interaction effects were observed in none of the sites. The

main effect of applying nitrogen fertilizer at one-third at sowing and two-third at tillering gave the highest yield with a yield advantage ranging from 1 to 24% over the control.

Table 1. Analysis of variance for grain yield of rice at each site on the Vertisols of Fogera plain.

Source of variation	Site-1	Site-2	Site-3	Site-4
N rate (N)	NS	NS	NS	NS
Time of N application (T)	*	*	NS	NS
N X T	NS	NS	NS	NS
Mean yield (kg ha ⁻¹) of control (T ₁)	4309	3872	2912	4796
Highest mean yield (kg ha ⁻¹)	5353	4142	2940	5203
Time of N application for highest mean yield	T ₃	T ₃	T ₃	T ₃
Yield advantage over the control (%)	24.2	7.0	1.0	8.5
SE	153.65	108.17	112.21	152.08

* Significant at 5 % level of significance, NS = Non-significant at 5 % level of significance; T₁ = N applied half at planting + half at tillering (control), T₃ = N applied one-third at planting + two-third at tillering.

Combined analysis over four environments of site-year combinations revealed that first and second order interactions of nitrogen rates with time of applications and environments were not significant for grain yield and other parameters (Table 2). First and second order interactions of environments with nitrogen rates and application times were also not significant for grain yield, indicating that no need for environment specific recommendation. The main effects of nitrogen fertilizer rates were also not significant for grain yield and other parameters as opposed to the main effects of time of applications that showed significant ($p < 0.05$) grain yield difference (Table 2).

The highest significant grain yield of 4409 kg ha⁻¹ was obtained when nitrogen was applied one-third at sowing and two-third at tillering (Table 3). The lowest yields of 3767 and 3772 kg ha⁻¹ were obtained when nitrogen was applied half at sowing and half at panicle initiation, and one-third at sowing plus one-third at tillering plus one-third at panicle initiation, respectively (Table 3). The result indicated that relatively higher amount of nitrogen should be applied at tillering than at sowing or at panicle initiation so as to increase the number of grains and subsequently higher grain yield.

Table 2. Combined analysis of variance over four site-year environments for grain yield and some yield components of rice grown on the Vertisols of Fogera plain.

Source of variation	Grain yield (kg ha ⁻¹)	Number of fertile panicles m ⁻²	Thousand grain weight (g)	Plant height (cm)
Site(S)	**	NS	**	**
N	NS	NS	NS	NS
SxN	NS	NS	*	NS
Time of N application (T)	*	NS	NS	NS
SxT	NS	NS	NS	NS
NxT	NS	NS	NS	NS
SxN x T	NS	NS	NS	NS
SE	101.44	5.19	0.23	0.78

*, ** and NS denote significant differences at 5 and 1% level of significance and none significant difference, respectively.

This finding is in line with Cassman *et al.* (1998) who claimed that a greater portion of the N requirement should be applied during active tillering stage at which crop growth is rapid and N demand is high. The N demand at the very young growth stage of the rice crop is so low (Schnier *et al.*, 1987). Furthermore, N available from the mineralization of organic matter is greatest during this phase (Dei and Yamasaki, 1979) and should be adequate to meet crop needs during the early growth stage.

Table 3. Grain yield of rice as affected by nitrogen fertilizer rates and split application times on the Vertisols of Fogera plain, combined over four site-year environments.

Time of N split applications	Fertilizer rates (kg ha ⁻¹)		
	46/46 N/P ₂ O ₅	69/23 N/P ₂ O ₅	Mean*
Half at sowing and half at tillering (control)	4001	3944	3972 ^b
Half at sowing and half at panicle initiation	3899	3635	3767 ^b
One-third at sowing and two-third at tillering	4357	4462	4409 ^a
One-third at sowing and two-third at panicle initiation	3961	4215	4088 ^{ab}
One-third at sowing, one-third at tillering and one-third at panicle initiation	4120	3425	3772 ^b
Mean	4067	3936	

*Values followed by the same letter in a column are not significantly different at 5% probability level of significance.

The current result also revealed that application of nitrogen in two splits is preferable than three splits and gave yield advantage of 637 kg ha⁻¹ (16.8 %). This is in agreement with a lot of results (George, 1980; Haefele *et al.*, 2006; Marqueses *et al.*, 1988) which recommended two split applications of N fertilizer for rice production. Though number of authors recommended two split applications, there is variation in the timings of nitrogen fertilizer split applications for rice. Marqueses *et al.* (1988) reported that application of one-third N band placed at 20 days after sowing and two-third N at 5-7 days before panicle initiation gave significantly higher grain yields (8.5 t ha⁻¹) and agronomic efficiency (60 kg grain per kg N applied). The results of George (1980) showed that two split applications given at maximum tillering and panicle initiation stages gave higher grain yield than three splits applied at 10 days after rice emergence, maximum tillering and panicle initiation stages. Haefele *et al.* (2006) also recommended two split nitrogen fertilizer applications at basal and panicle initiation for rainfed lowland rice production in Thailand.

Conclusion and Recommendations

The results of this experiment revealed that split nitrogen fertilizer application timing is one of the important management factors for improving lowland rice productivity and production on the Vertisols of Fogera plain, where rice has been grown as monocrop. Split application of one-third at sowing and two-third at tillering stage of rice was the highest yielding among the tested split application time treatments. Therefore, split application of nitrogen with one-third at sowing and two-third at tillering stage is recommended for rice production on the Vertisols of Fogera plain, as it gave 11% yield advantage (437 kg grain ha⁻¹) over the control.

References

- Cassman, K.G., Peng, S., Olk, D.C., Ladha, J.K., Reichardt, W. and Dobermann, A. 1998. Opportunities for increased nitrogen use efficiency from improved resource management in irrigated systems. *Field Crops Res.* 56:7–39.

- Charles, E. 2003. Revised guide for rice fertilization. Rice Research and Extension Center, University of Arkansas, USA.
- Consuelo, M.P., Bienvenido, O.J., Samuel, P.L., Jovencio, M.A. and Kenneth, G.C. 1996. Effects of late nitrogen fertilizer application on head rice yield, protein content and grain quality of rice. *Cereal Chemistry* 73(5):556-560.
- CEDEP (Consultants on Economic Development and Environmental Protection). 1999. Amhara National Regional State (ANRS)-Agricultural Research Master Plane. Vol.1–main report. ANRS Bureau of Agriculture, Bahir Dar, Ethiopia.
- Dei, Y. and Yamasaki, S. 1979. Effect of water and crop management on the nitrogen supplying capacity of paddy soils, pp.451-463. In: Nitrogen and Rice. International Rice Research Institute, Los Baños, Philippines.
- George, I. 1980. Effects of level, time, and splitting of urea on the yield of irrigated direct seeded rice. *Plant and Soil* 56(2): 209-215.
- Haefele, S.M., Naklang, K., Harnpichitvitaya, D., Jearakongman, S., Skulkhu, E., Romyen, P., Phasopa, S., Tabtım, S., Suriya-arunroj, D., Khunthasuvon, S., Kraisorakul, D., Youngsuk, P., Amarante, S.T. and Wade, L.J. 2006. Factors affecting rice yield and fertilizer response in rainfed lowlands of northeast Thailand. *Field Crops Research* 98: 39-51.
- James, E. and Stribbling, L. 1995. Fertilizer management to protect water quality. In: Agricultural and Natural resource water quality controlling. Alabama A & M and Auburn Universities.
- Kissan-Kerala. 2007. Fertilizers Management. <http://www.kissankerala.net/kissancontents/.jsp>. 1van. 29/10/2007 12:53.
- Marqueses, Z.E.P., Schnier, H.F., Dingkuhn, M., Faronilo, J.E., Javellana, C.B., Wijangco, J.E. and De Datta, S.K. 1988. Effects of timing and method of nitrogen application on grain yield, agronomic efficiency, plant nitrogen and dry matter yield in transplanted and direct seeded lowland rice. *Philippine Journal of Crop Science* 13:12-16.
- Schnier, H.F., De Datta, S.K. and Mengel, K. 1987. Dynamics of N labeled ammonium sulfate in various inorganic and organic soil fractions of wetland rice soils. *Biol. Fert. Soils* 4: 171–177.

- Stevens, G., Hefner, S. and Gladbach, T. 2001. Effect of nitrogen timing and rates on tillering and yield of rice. *Soil Science and Plant Analysis* 32:421-428.
- Tesfaye Zegeye, Befekadu Alemayehu and Aklilu Agidie. 2005. Rice production, consumption and marketing: The case of Fogera, Dera and Libokemkem Districts of Amhara Region. Paper presented on the National workshop on the status of rice research and promotion in Ethiopia. 3-4 June 2005, Bahir Dar, Ethiopia.
- Tilahun Tadesse, Minale Liben, Alemayehu Assefa, Belesti Yeshalem and Tesfaye Wossen. 2007. Effect of nitrogen and phosphorus fertilizers on the yield of rice in Fogera and Metema areas. In: Ermias A, Akalu T, Alemayehu A, Melaku W, Tadesse D, and Tilahun T (eds.). Proceedings of the 1st Annual Regional Conference on Completed Crop Research Activities, 14- 17 August 2006. Amhara Regional Agricultural Research Institute. Bahir Dar, Ethiopia.
- Yihenu Gebreselassie. 2002. Selected chemical and physical characteristics of soils of Adet Research Center and its testing sites in northwestern Ethiopia. *Ethiopian Journal of Natural Resources* 4(2):199-215.
- Zaheen, M., Ali, R.I., Awan, T.H., Khalid, N. and Ahmad, M. 2006. Appropriate time of nitrogen application to fine rice, *Oryza sativa*. *J. Agric. Res.* 44(4):261-266.

Fruit tree species in the wilderness: Species composition and level of use in western Amhara

Fentahun Mengistu¹ and Herbert Hager²

¹Amhara Regional Agricultural Research Institute(ARARI), P.O.Box 527, Bahir Dar, Ethiopia

Email: fentahunmen@yahoo.com

²Boku University of Natural Resources and Applied Life Sciences, Peter-Jordan Street 82, A-1190 Vienna, Austria

Email: Herbert.hager@boku.ac.at

Abstract

The study was undertaken in selected areas of Adiarkay, Debark and Dejen districts of Amhara Region to assess the species composition and diversity and sate of use of wild fruit species. Data were gathered through interviews administered to 90 randomly chosen household heads and inventory of fruit trees. Results revealed the availability of 48 wild fruit species for use in different land use types and niches. Species diversity is generally low in agricultural settings where only 17 species were recorded. Species retention in farmlands appears to be governed by species relative importance and compatibility with annual crops where farm edges recorded a higher ethno-ecological importance score. Nonetheless, the current state of fruit utilization appears insignificant which is mainly accounted for peoples' cereal-based alimentation habit, cultural perceptions and attitudes. Fruit bearing species are retained primarily for non-fruit utilities like fuel wood and construction. Consequently, the potential contribution of wild fruits in peoples' diet remains largely unexploited. For a wider acceptance and achievement of sustainable behavioral changes, rigorous promotion and mainstreaming are required.

Key words: Domestication, diversity, utility, wild fruits.

Introduction

Edible wild plants have sustained people throughout history and their consumption has been documented from antiquity into the Common Era (Grivetti and Ogle, 2000). Gathered in the wild, wild fruits provide cheap food, add variety to diets, improve palatability, and provide essential vitamins, minerals, protein and calories. They also form an important component of coping strategies in times of severe famine (Guinand and Dechassa, 2000). Many of the wild edible fruit species have also great potential for processing. In an

agroforestry system they often offer multipurpose advantages (Shrestha and Dhillion, 2006) and can help in soil and water conservation. Given that they are adapted to the local environment, wild fruits can grow easily with few requirements for external input and be integrated into sustainable farming systems. Since the distant past, Ethiopian people have also widely used wild and semi-wild plants that are estimated over 200 species (Edwards, 1992; Getachew *et al.*, 2005). Despite this fact, wild plants especially fruit bearing species suffer notable disregard from research and development plans of Ethiopia. Consequently, they remain inadequately documented and are becoming unfortunate victims of deforestation and prone to extinction. This article examines fruits gathered in the wilderness with respect to species diversity, level of domestication and state of exploitation in the Western Amhara region of Ethiopia.

Materials and methods

The study was conducted in Adiarkay, Debarq and Dejen districts of the Amhara region in Ethiopia between 2006 and 2008. Details of geographical location, climate, soils and agro-ecological coverage of the study Woredas are presented in Tables 1 and 2. Both qualitative and quantitative approaches were employed for data collection. Structured and semi-structured interviews were administered to document informants' attributes, enumerate floristic composition and understand people's practices and preferences. By reaching all farms of randomly selected households, assessment of wild fruits' species richness and diversity at the working landscape was carried out by counting all available species.

Data processing and analysis were done in various ways. Total species richness was calculated by counting the number of species. Average species richness was calculated using sample-based exact species accumulation curves as per Kindt and Coe (2005). Shannon Diversity Index (H) was used as diversity indicator and was calculated as (Magurran, 1988):

$$H = -\sum P_i * \ln P_i$$

where, H = Shannon Diversity Index, P_i = proportion of individuals found in the i^{th} species, \ln = is the natural logarithm of this proportion.

Table 1. Geographical location, climate and soils of the study *Woredas*.

Woreda	PA(site)	Latitude		Altitude Meters	average total rainfall by Woreda mm	X monthly Max.temp. by Woreda (°C)	X monthly Min.temp. by Woreda (°C)	Rh (%)	(%) soil type cover by Woreda								
		N	E						Lepiso (l)	Acrisols	Cambsols	Lithosols	Nitisols	Phaeozems	RenZinas	Vertisols	Luvosols
Debark	Debir	13.15	37.92	2885	1033.2	19.9	8.9	53.5	0	48.5	25.2	11.0	3.4	11.8	0.0	0.0	0.0
	Dib Bahir	13.24	37.89	2116													
Adiarkay	Ber Mariam	13.40	37.00	1620	1110.9	27.6	13.3	na	48.2	0.0	51.8	0.0	0.0	0.0	0.0	0.0	0.0
	Adiaregay	13.45	38.06	1553													
Dejen	Kurar	10.08	38.19	1360	1343.9	na	na	na	0.0	0.0	0.0	0.0	20.1	0	40	39.9	0.0

Table 2. Percent agro-climatic zone coverage of the study *Woredas* based on the contemporary and traditional classification systems.

Woreda	% agro-climatic zone coverage under the new classification system								% agro-climatic zone coverage under the traditional classification system					
	SM1	SM2	SH3	M1	M2	M3	SH1	SH2	Tepid moist	Kolla (600-1500 m)	Woina Dega (1500-2300m)	Dega (2300-3200m)	Wurch (3200-3600m)	(3 600-4400m)
Adiarkay	0.0	10.0	8.0	19.9	53.7	16	0.0	0.0	0.52	24.4	43.5	20.6	11.6	0.0
Debark	0.0	0.0	0.0	3.0	81	16	0.0	0.0	0.0	14.4	47.5	34.1	2.7	1.3
Dejen	0.0	0.0	0.0	22	78	0.0	0.0	0.0	0.0	25.4	37.7	36.9	0.0	0.0

$SM1$ = Hot to warm sub-moist; $SM2$ = Tepid to cool sub-moist; $M1$ = Hot to warm moist; $M2$ = Tepid to cool moist; $M3$ = Cold to very cold moist; $SH1$ = Hot to warm sub-humid; $SH2$ = Tepid to cool subhumid; $SH3$ = cold to very cold sub-humid

Evenness (E) was calculated as the ratio of observed diversity to maximum diversity as Pielou (1969):

$$E = \frac{H'}{\ln S}$$

where, H' = Shannon diversity index, S = species richness

To order communities in diversity, Rényi diversity profiles were used and calculated as Kindt *et al.* (2006):

$$H\alpha = \frac{\ln(\sum Pi\alpha)}{1-\alpha}$$

where, $H\alpha$ = Rényi diversity profile, Pi = proportional abundance of a species, α = scale parameter with values 0, 0.25, 0.5, 1, 2, 4, 8 and ∞ . The values at $\alpha = 0, 1, 2$ and ∞ correspond to species richness, Shannon diversity index, reciprocal Simpson and Berger-Parker diversity indices.

Species and tree density were calculated (both at farm and site level) dividing the total number of species or trees by the size of the farm and total area of all farms of a site, respectively. Species composition similarities and differences of sampling sites were compared based on ecological distances where species similarity of sites (Beta Diversity) was judged using Sorenson index proposed for qualitative data as (Magurran, 1988):

$$D = \frac{2j}{a+b}$$

where, D = distance, j = the number of species found in both sites, a = the number of species in site A, and b = number of species in site B. The results were then subtracted from unity to show in terms of distance or dissimilarity value.

To linking the cultural information to ecological data, Ethno-ecological Importance Value (EIV) was calculated following Castaneda and Stepp (2007) as:

$$EIV = \sum_{x=1}^N (S) \left(\frac{nx}{Nx} \right)$$

where, N = total number of species in all niches; S = Smith's Saliency Index, nx = total number of individuals of species "x" found in one niche, Nx = the sum of species "x" found in all niches.

Statistical softwares, SPSS for windows version 15 and Biodiversity R. (Kindt and Coe, 2005) built on the free R 2.1.1 statistical program and its contributing packages (R Development Core Team, 2005), were employed for data analysis.

Results and discussion

Species composition, life forms and habitats

The study documented a total of 48 species of wild edible fruit bearing plants that are classified among 32 genera and 24 families (Table 3). The greatest contribution of edibles comes from Moraceae family, represented by five species, the runner-ups being Rhamnaceae and Tiliaceae each represented by four species.

Table 3. Lists of species recorded across the study sites.

Botanical Name	Family	Common / English name	Life form
<i>Acacia etbacia</i> Schweinf	Fabaceae	Red thorn	tree
<i>Carissa edulis</i> (Forsk.) Vahl	Apocynaceae	Simple-spined carissa	shrub/tree
<i>Carissa spinarum</i> Linn.	Apocynaceae		shrub/tree
<i>Cordia africana</i> Lam.	Boraginaceae	East African Cordia	tree
<i>Cordia ovalis</i> R.Br.	Boraginaceae		shrub/tree
<i>Diospyros mespiliiformis</i> Hochst. Ex. A. DC.	Ebenaceae	African Ebony, Jackal-berry	tree
<i>Dovyalis abyssinica</i> (A.Rich.) Warb.	Flacourtiaceae	Kei Apple	shrub/tree
<i>Ekebergia capensis</i> Sparrm	Meliaceae		tree
<i>Ensete ventricosum</i> (Welw.) Cheesman	Musaceae	False banana, Wild anana	herb
<i>Euclea schimperii</i> Murr.	Ebenaceae		shrub
<i>Ficus sur</i> Forssk. (<i>F. Capensis</i>)	Moraceae	Cape fig	tree
<i>Ficus sycomorus</i> L.	Moraceae	Wild fig, Bush fig	tree
<i>Ficus thonningii</i> Blume	Moraceae	Bark-cloth fig, common wild fig	tree
<i>Ficus vallis-choudae</i> Delile	Moraceae	False cape fig	tree
<i>Ficus vasta</i> Forssk.	Moraceae		tree
<i>Flueggea virosa</i> (Willd.) Vigot	Euphorbiaceae	snowberry tree	shrub
<i>Gardenia ternifolia</i> Schumach and Thonn	Rubiaceae		tree
<i>Grewia bicolor</i> A. Juss.	Tiliaceae	False brandy bush	shrub
<i>Grewia ferruginea</i> Hochst.ex A. Rich.	Tiliaceae		shrub/tree
<i>Grewia flavescens</i> Juss.	Tiliaceae		shrub
<i>Grewia</i> sp.	Tiliaceae		shrub
<i>Lantana camara</i> L.	Verbenaceae	Lantana,Red-flowered sage	shrub
<i>Lepisanthes senegalensis</i> (Poir)Leenh.	Sapindaceae	Senegal cherry	tree
<i>Mimusops kummel</i> A. DC.	Sapotaceae		tree
<i>Myrsine africana</i> L.	Myrsinaceae	African boxwood	shrub/tree
<i>Oncoba spinosa</i> Forssk.	Flacourtiaceae	Snuff-box tree	tree
<i>Opuntia ficus-indica</i> (L.)Miller	Cactaceae	Indian fig	shrub
<i>Phoenix reclinata</i> Jacq.	Arecaceae	False/Wild date palm	palm
<i>Piliostigma thonningii</i> (Schumach.) Milne-Redh.	Fabaceae	Camel's foot, Monkey bread	tree
<i>Rhus glutinosa</i> A. Rich.	Anacardiaceae		tree
<i>Rhus vulgaris</i> Meikle	Anacardiaceae		shrub
<i>Rosa abyssinica</i> Lindley.	Rosaceae	Abyssinian rose	shrub/climber/tree
<i>Rubus apetalus</i> Poir.	Rosaceae	wild raspberries	shrub
<i>Rubus steudneri</i> Schweinf.	Rosaceae	wild raspberries	shrub
<i>Sterculia africana</i> (Lour) Fiori	Streculiaceae		tree
<i>Stychnos innocua</i> Del.	Loganiaceae	Monkey orange, wild orange	tree
<i>Syzygium guineense</i> (Willd.)DC:	Myrtaceae	Water berry	tree
<i>Tamarindus indica</i> L.	Fabaceae	Tamarind tree, Indian date	tree
<i>Vangueria madagascariensis</i> J.F Gmel.	Rubiaceae		shrub/tree
<i>Ximenia americana</i> L.	Olaceae	Wild plum, hog plum	shrub/tree
<i>Ziziphus abyssinica</i> Hochst. ex A. Rich	Rhamnaceae	Jujube	shrub/tree
<i>Ziziphus mucronata</i> Willd.	Rhamnaceae	Cape thorn, Buffalo thorn	shrub/tree
<i>Ziziphus species</i>	Rhamnaceae	Jujube	shrub
<i>Ziziphus spina-christi</i> (L.)Desf.	Rhamnaceae	Christ thorn, Jujube	tree

Thirteen families (30%) are represented by only one species. The richest genus was *Ficus* that comprised of five species followed by *Grewia* and *Ziziphus* with three species at par. It was also noted that species known in cultivation like *Citrus* spp. and *Coffee* sometimes grow in the wilderness especially in churchyard and monastery forests and regarded as wild by the community. Most of the recorded species were trees (45.5%) while a quarter of them occur as shrubs and another quarter opportunistically either as shrubs or trees. Wild fruit species appeared to occupy various habitats and ecological niches. Some species naturally inhabit forests and scrubs (e.g. *Rosa abyssinica*) or often open forests and heaths (*Ziziphus spina-christi*). Species such as *Ximenia americana* were frequent on highly degraded sites. Other species like *Syzygium guineense* are characteristically riparian. Some others such as *Fluggea virosa* were frequently found on roadsides and disturbed areas.

Species distribution by altitude and traditional agro-ecological zones

The majority of wild fruit species were recorded in the low to mid altitude continuum. Barring the naturalized domesticated species, out of the total species recorded, 31, 38 and 7 species occurred in the 1200-1500 m, 1500-2300 m and 2300-3300 m altitudinal ranges, respectively. By and large, at altitudes of 3300m and above or in the mountain tops, *Rosa abyssinica* appears to be prominent species. *Rubus steduneri* and *Dovyalis abyssinica* follow at about 2800 m a.s.l and 2600 m a.s.l, respectively. *Tamarindus indica*, *Ximenia americana*, *Ziziphus mucronata* and *Grweia* species were dominant at the lower altitude in the study area, 1200 m a.s.l in the Blue Nile Gorge.

Variability in species composition of sites

The study sites appear to differ substantially in their number and type of edible fruit species. Adiaregay, Dibbahir and Bermariam sites had generally closer species compositions (Table 4). Species composition variability can be attributed to differences in elevation and thus climate among sites that provide a wide array of niches for different species. As one goes from lower towards the higher altitudes, both the level of domestication and the number of species and trees per farm progressively and then sharply dwindles. This can be interpreted by both natural and man-made factors. Highlands like the Debir area (Table 1) that at times experience freezing temperatures could restrict the

occurrence of several species. On the other hand, the highlands are the most populated sites where anthropogenic factors culminated in severe land degradation and deforestation which could also have direct bearing on indigenous fruit species populations. As a result, the poor natural vegetation backdrop of the higher altitudes might not offer farmers a wider chance to find trees to be retained which would ultimately result in low diversity on those sites located at higher elevations.

Table 4. Sorenson distance and number of species shared between sites (agglomerative coefficient = 0.48).

Species	Distance				Number (percent) of species shared			
	Dibbahir	Bermariam	Adiaregay	Kurar	Dibbahir	Bermariam	Adiaregay	Kurar
Debir	0.49	0.67	0.55	0.74	9(20.5)	6(13.8)	7(15.9)	5(11.4)
Dibbahir	0	0.18	0.13	0.47	0	21(47.7)	20(45.5)	14(31.8)
Bermariam	*	0	0.19	0.56	*	0	19(43.2)	12(27.3)
Adiaregay	*	*	0	0.55	*	*	0	11(25.0)

Species composition in the agricultural landscape

The study revealed that, despite at low level, indigenous fruit bearing species are domesticated in the realm of anthropogenic ecosystems through mainly retaining natural regenerants. Accordingly 17 fruit bearing species were recorded in the working (agricultural) landscape (Table 5). Over the total study area, 74.5 % (n = 90) of the informants were found to possess one or more of these species in their plots. Nonetheless, species richness and abundance is very low. The mean number of species per household, density per farm and per site is 2.3, 2.6 and 1.6, respectively (Table 6). On a site basis, Bermariam appears to be superior with all the above parameters while Debir recorded the lowest number of species. The lowest density per farm and per site was at Dibbahir. Pertaining species abundance, the total number of trees of all species of all sites (N = 70) was calculated at 754 with an average of 10.8 ± 11.89 trees per household. The mean tree density per farm and per site was 10.7 ± 15.11 and 7.6, respectively (Table 6).

Table 5. Relative and mean species abundance of indigenous fruit species in the agricultural landscapes.

Species	Family	English name	Species abundance		Mean number of fruit tree species per household by site				
			Abundance	Proportion	Adiaregay	Bermariam	Debir	Dibbahir	Kurar
<i>Flueggea virosa</i> (Roxb. ex Willd.)	Euphorbiaceae	Snowberry tree	227	30.1	7.6	5.7	0.0	0.3	0.0
<i>Ziziphus spina-christi</i> (L.) Desf	Rhamnaceae	Christ thorn, Jujube	177	23.5	6.6	3.9	0.0	0.0	0.0
<i>Cordia africana</i> Lam.	Boraginaceae	East African Cordia	173	22.9	2.2	2.4	0.0	5.1	2.4
<i>Ficus</i> species	Moraceae	Figs	48	6.4	0.8	1.7	0.0	0.1	0.2
<i>Rosa abyssinica</i> R. Br.	Rosaceae	Abyssinian rose	37	4.9	0.0	0.0	3.1	0.0	0.0
<i>Carissa</i> species	Apocynaceae	Carissa plum	28	3.7	0.8	0.6	0.0	0.4	0.0
<i>Diospyros mespiliformis</i> Hochst. ex A. DC.	Ebenaceae	Jackal-berry	18	2.4	0.9	0.2	0.0	0.0	0.0
<i>Tamarindus indica</i> L.	Fabaceae	Tamarind	11	1.5	0.0	0.0	0.0	0.0	1.1
<i>Ficus thonningii</i> Blume	Moraceae	Bark-cloth fig	10	1.3	0.1	0.5	0.0	0.0	0.0
<i>Rhus</i> species	Anacardiaceae		10	1.3	0.2	0.3	0.0	0.1	0.0
<i>Syzygium guineense</i> (Willd.) DC.	Myrtaceae	Water berry	7	0.9	0.0	0.0	0.0	0.5	0.0
<i>Dovyalis abyssinica</i> (A. Rich.) Warb.	Flacourtiaceae	Kei Apple	2	0.3	0.0	0.0	0.2	0.0	0.0
<i>Phoenix reclinata</i> Jacq.	Arecaceae	Wild date palm	2	0.3	0.0	0.0	0.0	0.1	0.0
<i>Ximenia americana</i> L	Olacaceae	Wild plum	1	0.1	0.0	0.1	0.0	0.0	0.0
<i>Opuntia ficus-indica</i> (L.) Mill.	Cactaceae	Indian fig	1	0.1	0.0	0.0	0.1	0.0	0.0
<i>Ziziphus abyssinica</i> Hochst. ex A. Rich.	Rhamnaceae	Jujube	1	0.1	0.0	0.1	0.0	0.0	0.0
<i>Vangueria madagascariensis</i> J.F. Gmelin	Rubiaceae		1	0.1	0.0	0.0	0.0	0.1	0.0

Table 6. Mean species richness, abundance and diversity of individual sites and entire the study area.

Sites	Number of species household ⁻¹ (± Sd*)	Number of trees household ⁻¹ (± Sd)	Tree density (± Sd)		Species density (±Sd)		Diversity Index		Landholding household ⁻¹ (± Sd)
			Density farm ⁻¹	Density site ⁻¹	Density farm ⁻¹	Density site ⁻¹	Shannon Diversity	Evenness	
Adiaregay(N=16)	2.8±1.17	19.1±16.14	16.6±15.60	9.6	3.1±3.19	1.4	1.46	0.54	1.98±1.56
Bermariam(N=18)	3.3±1.41	15.4±12.24	17.2±23.30	11.1	3.4±2.25	2.4	1.66	0.52	1.39±0.89
Debir(N=12)	1.3±0.45	3.3±2.50	5.3±3.70	4.4	2.3±1.80	1.5	0.31	0.46	0.76±0.44
Dibbahir(N=14)	1.6±0.93	6.7±4.61	5.1±3.00	3.9	1.5±1.25	1.0	0.98	0.33	1.73±1.50
Kurar(N=10)	1.6±0.50	3.7±2.50	4.0±1.90	3.8	2.0±0.93	1.6	0.80	0.74	0.98±0.58
All sites(N=70)	2.3±1.32	10.8±11.89	10.7±15.11	7.6	2.6±2.21	1.6	1.86	0.38	1.43±1.19

* Sd = standard deviation

A lower figure with the later might mean that farms are less evenly stocked across households. Besides, species abundance appeared to differ by site as did the species richness. The highest and lowest relative species abundances were recorded at Adiaregay (19.1 ± 16.11 trees per farm) and Debir (3.3 ± 2.50 trees per farm), respectively. However, mean tree density per farm and site was highest at Bermariam than Adiaregay signifying that despite their large sizes farms at the latter are less adequately stocked. Kurar recorded the lowest density of trees both at the farm and site levels which could be accounted for the extreme environment that prevents agroforestry practice in the area.

Species diversity and pattern

The Shannon diversity index for the entire study area was calculated at 1.86 (Table 6), which is about 65.7% of the maximum possible value that would have been obtained had all species occurred at equal frequency (2.83). This suggests that the study area has a moderate level of diversity. Looking at only species richness the five sites can be grouped into two; those with relatively higher species richness (Bermariam, Adiaregay and Dibbahir) and those with lower species richness (Kurar and Debir) (Figure 1). In terms of diversity, by having consistently higher profiles than other sites, Bermariam followed by Adiaregay appeared to have higher species diversity. By the same analogy, Debir appeared least diverse by recording the lowest profile. On the other hand, Dibbahir could not be ordered in diversity with Kurar as they had corresponding diversity profiles that intersect. This happened because Dibbahir had higher species richness but lower evenness than the Kurar site. Kurar is relatively species even while Dibbahir is less even.

This can be explained by the fact that Dibbahir being a transitional zone favorable to accommodate various ranges of species, the probability of some species to dominate is higher resulting in uneven species composition at the total landscape level. This would in turn govern farm species richness and people's choice of species for retaining. Conversely, the harsh climate at Kurar could limit the ability of any single or group of species to dominate in the natural milieu that would consequently narrow species choice for farm integration resulting in even species distribution.

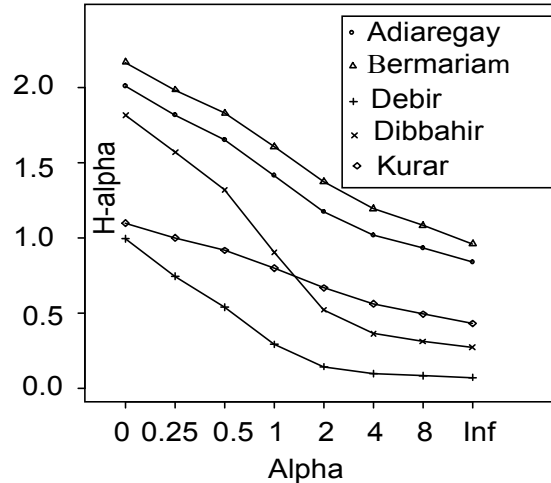

Figure 1. Rényi species diversity profile for study sites (based on 100 randomizations).

The inter-site differences in farm species richness seem largely governed by the overall species richness setting of the respective localities. This means that the more parent trees present in the natural environment the higher the probability that farmers retain more trees in their farms. For instance, at Bermariam where there is a better vegetation cover in the natural milieu (partly for its proximity to the Waldba Monastery) so is a higher level of species integration in the agricultural landscapes while the opposite is true at Debir site. However, at the Kurar site where there is relatively lower species richness in the natural environment the level of farm integration is low. This could probably be explained by its extremely dry climate that appears unattractive for agroforestry development or the tradition of tree retention by the community is low.

Fruit species diversity by land use type

Comparison of the different land use types revealed that the average species richness declines in the following order: farm edges (12), grazing and uncultivated lands (11), farmlands (10), and homesteads (8). However, in terms of diversity farmlands (1.71) followed by uncultivated lands (1.65) are more diverse than homesteads (1.29). With regard to evenness, farmlands tend to be even while the farm edges are less even. Farm edges (1.49) appear to be ethno-ecologically very important suggesting that these sites are important sources of indigenous fruit bearing species to the people. Besides, the different land use types differ by species type. Generally, farmlands and homesteads are dominated by *Z. spina-christi* and *C. africana* which seems related to relative

importance and compatibility of species for inter-cropping (Table 7). Highly frequent and high utility species for the major part overlap with the most abundant species demonstrating that most people are growing species of higher preferences in large numbers that can be taken affirmative in view of sustainability of species.

Utilization

The extant level of wild fruit consumption was found to be infrequent and limited to casual encounters; 52.2% of informants stated that consumption was sporadic. Wild fruit gathering is interpreted as being famished and its consumption connotes indignity and social stigma. Children are the major consumers as the majority of informants conceded (70.7%, n=92) which is in a good agreement with previous findings (Guinand and Dechassa, 2000; Getachew *et al.*, 2005). Particularly, twelve fruit species are considered children category (*F.virosa*, *Ficus spp.*, *F.thonningi*, *Rhus spp.*, *O.spinosa*, *S.africana*, *S.innocua*, *Rubus spp.*, *E.ventricosum*, *C.africana*, *Grewia spp.*, *P.reclinata*). Adults regard wild fruits diminutive food value and avoid their consumption. This is certainly because grown-ups get succumb into the culture of the society that regards wild fruits a low status and their consumption a source of shame. It was also found out that the intensity of use of some wild fruits as *Z.spina-christi* increase as a response to adversity. Specifically people recount the widespread drought of the year 1984/85 and the subsequent famine where several people especially the poor populace survived of increased consumption of wild fruits. Especially memories of reliance on *Z.spina-christi*, which had intensively been consumed, bartered and sold during that time are still alive among people. This shows the prospective role of wild fruits as a local response to adaptation and mitigation of the impending capricious climate.

Most of the edible fruits were found to be eaten fresh and raw and sometimes dried as snacks as was widely reported elsewhere (Van den Eynden, 2003). Nevertheless, in some seven fruit species a sort of home processing is practiced. They are commonly processed into either a form of refreshing juice (*Carissa spp.*, tamarind, *C.africana* Lam. and *Zspina-christi*) or brewed into local beers with or without the addition of a fermenting agent (*Rhamnus prinoides* L'Hér.), or are added as flavorings (*C.africana* and *Carissa* species) to local drinks.

Proceedings of the 4th Annual Regional Conference on Completed Research Activities, ARARI 2012

Table 7. Comparison of the ethno-ecological importance value of the different land use types of the agricultural settings as a source of indigenous fruit bearing plant species.

Species	Species saliency score	Proportional abundance							
		Grazing/					Species saliency X abundance		
		Farmland	Homestead	Farm edge	uncultivated land				
A	B	c	D	e	a X b	a X c	a X d	a X e	
<i>Cordia africana</i> Lam.	0.51	0.18	0.65	0.14	0.02	0.09	0.33	0.07	0.01
<i>Ficus</i> species	0.43	0.19	0.21	0.42	0.19	0.08	0.09	0.18	0.08
<i>Diospyros mespiliformis</i> Hochst. ex A. DC.	0.27	0.00	0.56	0.22	0.22	0.00	0.15	0.06	0.06
<i>Ziziphus spina-christi</i> (L.) Desf	0.40	0.23	0.38	0.31	0.08	0.09	0.15	0.12	0.03
<i>Flueggea virosa</i> (Roxb. ex Willd.)	0.26	0.06	0.00	0.72	0.22	0.02	0.00	0.19	0.06
<i>Rhus</i> species	0.17	0.00	0.00	0.80	0.20	0.00	0.00	0.14	0.03
<i>Carissa</i> species	0.56	0.11	0.00	0.43	0.46	0.06	0.00	0.24	0.26
<i>Ficus thonningii</i> Blume	0.06	0.20	0.10	0.60	0.10	0.01	0.01	0.03	0.01
<i>Ziziphus abyssinica</i> Hochst. ex A. Rich.	0.04	0.00	0.00	0.00	1.00	0.00	0.00	0.00	0.04
<i>Ximenia americana</i> L	0.29	0.00	0.00	0.00	1.00	0.00	0.00	0.00	0.29
<i>Rosa abyssinica</i> R. Br.	0.33	0.08	0.62	0.30	0.00	0.03	0.21	0.10	0.00
<i>Syzygium guineense</i> (Willd.) DC.	0.28	0.14	0.00	0.86	0.00	0.04	0.00	0.24	0.00
<i>Phoenix reclinata</i> Jacq.	0.06	0.00	0.00	1.00	0.00	0.00	0.00	0.06	0.00
<i>Vangueria madagascariensis</i> J.F. Gmelin	0.12	0.00	0.00	0.00	1.00	0.00	0.00	0.00	0.12
<i>Dovyalis abyssinica</i> (A. Rich.) Warb.	0.12	0.50	0.50	0.00	0.00	0.06	0.06	0.00	0.00
<i>Opuntia ficus-indica</i> (L.) Mill.	0.03	0.00	1.00	0.00	0.00	0.00	0.03	0.00	0.00
<i>Tamarindus indica</i> L.	0.14	0.64	0.00	0.36	0.00	0.09	0.00	0.05	0.00
Total ethno-ecological importance value						0.57	1.03	1.49	1.00

When they are fermented with the addition of *R. prinoides* leaves *Z.spina-christi*, *R.abbyssinica*, *Rubus* spp., tamarind, *Ficus* spp. and *C. africana* are brewed into local beers “*Tela*” and “*Tej*” (a Mead) or without it to prepare “*Beerz*” (a Hydromel) or fruit infusion (tamarind) that is regarded as “*Areke*”. There is, however, a significant potential for the improvement of the contribution of some of the wild fruits through processing into salable products.

The study also revealed that some wild fruits are article of commerce at the close by rural markets and serve a source of income. Some fruits as *Z.spina-christi* are transported to distant markets like Addis Ababa and even to Sudan. For the most part wild fruit market disposal is done by women than men. Likewise, retailers as well as customers are for the most part women and children. The study further revealed that when wild fruit species are planted or retained in agricultural settings except in a few species they are primarily used for non-fruit functions and services overshadowing their fruit uses. Even then, the incorporation of these species on their present usage form can still be taken positive as it can help relieve the dwindling of these fruit species while at the same time increases biodiversity in the agricultural landscapes. For 13 species across the study areas more than 21 non-food use categories were documented. Comparison of species of more than one utilities showed that fuel wood (19.4%) followed by construction and fence at par (13%) are dominant use categories. On a species basis, *Z. spina-christi* has the greatest number of uses (11, 15.07%) followed by *C.africana* and *T. indica* (10, 13.7%) at par (Figure 2).

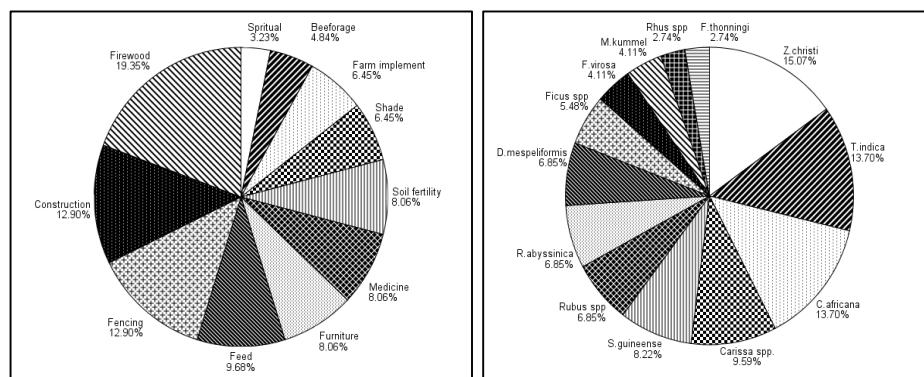

Figure 2. Percent contribution of species to the total use category (left) and Percent non-fruit use category of indigenous fruit species (right).

The multiple uses of these species attest to the enduring importance of these resources to local communities for subsistence and as part of their cultural heritage (Shrestha and Dhillon, 2006) while it can lead to better chances for their conservation (Etkin, 2002). Conversely, the harvesting of species with multiple uses can also put them under threat unless simultaneous balancing measures are taken. Therefore, should the wild fruit venture crowned with success, the study emphatically stress the necessity to promote value addition techniques. There is also a possibility to look for novel market opportunities. For instance, there is unexploited potential of targeting wild fruits to tourists around the Semen Mountains National Park area. Marketing of fruits like *Z.spina-christi* can also be thought of for livestock feed in the event of mounting animal feed scarcity.

Although the poorest sections of the communities in the study areas do make part of their living out of the collection and trading of wild fruits, their potential has hardly begun to be realized owing to food habits, cultural perceptions and attitudes. Therefore, in order to exploit the benefits of wild fruits to the full capacity, there is a need to foster their consumption through measures that ensure wider acceptance and to achieve sustainable behavioral changes. These may include vigorous promotion, public awareness campaigns and social marketing. It was also found that some species do not appeal to people because of their transitory undesirable characteristics. These warrant research in order to understand and improve the underlying anti-nutritional factors and compatibility to other agricultural activities.

Conclusion

Notwithstanding the marginal environment, the study area harbors a rich floral diversity of wild fruit plants. Albeit low and primarily for non-fruit utilities, indigenous edible fruit bearing species are domesticated in the agricultural settings. However, species diversity is low and too uneven among the different land use types, farms and sites. As a result, only few species of higher utilities and compatibility occur at higher frequencies in greater abundances. This is suggestive that as several agricultural land use types and sites are as yet less stocked, there is still a great scope to enhance farm species diversity by filling the

existing deficiency of richness and or evenness. Generally, introduction of indigenous fruit trees in the working landscape can be taken as positive development in view of conservation-through-use of the species. On the other hand, the current practice of retaining indigenous fruit species primarily for non-fruit uses means that their contribution to food and nutritional supplement of the households is far unexploited. Peoples' dietary habit, cultural perceptions and attitudes form the major part of the explanation for not using them as food. Should fruit trees in agricultural settings are additionally exploited for their fruits proper and make up part of peoples' livelihood, there is a need of creating farmers awareness and assisting them in appropriate tree management techniques and intercropping regimes. By doing so, it should be possible to evolve them from a practice of inadvertent tree growing exclusively for non-fruit uses to deliberate indigenous fruit tree agro-forestry development for both fruits and a range of other uses. The challenge would, however, be to justify the benefits that indigenous fruit production accrues to the producers' and make it profitable to adopt, which underpins the need for giving prime attention to create markets. There is generally a need for incorporating wild fruits in the region's development plan as part of a strategy to support farmers in their pursuit of ensuring food and nutritional security and poverty alleviation.

Acknowledgements

This paper is an output from a PhD dissertation of the first author funded by Austrian Exchange Service for which we are grateful. We are also highly indebted to BOKU University for hosting the first author for a PhD study. Our great thanks are due to the Amhara Regional Agricultural Research Institute for logistic and financial support. We give special thanks to farmers, district agricultural and rural development offices and several individuals who have been helpful in many ways during the fieldwork.

References

- Castaneda, H. and Stepp, J.R. 2007. Ethnoecological Importance Value (EIV) Methodology: Assessing the cultural importance of ecosystems as sources of useful plants for the Guaymi people of Costa Rica. *Ethnobotany Res. and Appl.* 5:249-257.

- Edwards, S.B. 1992. Traditional tree crops in Ethiopia: historical records and economic importance, pp159–168. In: Proceedings of the 2nd Natural Resources Conservation Conference, 10-13 May 1990. Institute of Agricultural Research, Addis Ababa, Ethiopia.
- Etkin, N.L. 2002. Local knowledge of biotic diversity and its conservation in rural Hausaland, northern Nigeria. *Econ. Bot.* 56(1):73-88.
- Getachew, A., Kelbessa, U. and Dawit, D. 2005. Ethnobotanical study of edible indigenous plants in some selected districts of Ethiopia. *Hum. Ecol.* 33(1):83–118.
- Grivetti, L.E. and Ogle, B.M. 2000. Value of traditional foods in meeting macro-and micronutrients needs: the wild plant connection. *Nutr. Res. Rev.* 13(1): 31-46.
- Guinand, Y. and Dechassa Lemessa. 2000. Indigenous food plants in Southern Ethiopia: Reflections on the role of ‘famine foods’ at the time of drought. UNEUE, Addis Ababa, Ethiopia.
- Kindt, R. and Coe, R. 2005. Tree Diversity Analysis. A manual and software for some common statistical methods for biodiversity and ecological analysis. World Agroforestry Centre (ICRAF), Nairobi, Kenya.
- Kindt, R., Van Damme, P. and Simons, A.J. 2006. Tree diversity in western Kenya: using profiles to characterise richness and evenness. *Biodiv. and Cons.* 15:1253–1270.
- Magurran, A.E. 1988. Ecological diversity and its measurement. Princeton University Press, N.J.
- Pielou, E.C. 1969. An introduction to mathematical ecology. Wiley, New York.
- Shrestha, P.M. and Dhillon, S.S. 2006. Diversity and traditional knowledge concerning indigenous food species in a locally managed forest in Nepal. *Agroforest Syst.* 66(1):55-63.
- SPSS 15.0.0 (6 Sept.2006). SPSS Inc. 1989-2006.
- Van den Eynden, V., Cueva, E. and Cabrera, O. 2003. Wild Foods from Southern Ecuador. *Econ. Bot.* 57 (4): 576-603.



LIVESTOCK

Characterization of milk production and marketing systems in Bure district of Amhara National Regional State, Ethiopia

Adebabay Kebede¹, Firew Tegegne², Zeleke Mekuriaw³ and Azage Tegegne⁴

¹Andassa Livestock Research Centre, E-mail: adugsen@gmail.com.

²Bahir Dar University, E-mail: firewtegegne@yahoo.co.uk.

³Bahir Dar University, E-mail: zelekemekuriaw@yahoo.co.uk.

⁴International Livestock Research Institute (ILRI), E-mail: a.tegegne@cgiar.org.

Abstract

Baseline information was collected to characterize the milk production systems in Bure district of the Amhara National Regional State. Data was obtained through individual interview of 181 households in single-visit-multiple-subject survey. Three milk production systems (rural smallholder, peri-urban and urban milk production) were identified in the district. Indigenous and Fogera x Friesian crossbreds were the dominant cattle breeds. Natural pasture, crop residues and aftermaths were the major livestock feed resources. Trypanosomiasis, pasteurolosis, anthrax and black leg were the major cattle diseases reported. Respondents identified lack of feed, disease outbreak, shortage of improved dairy cattle and distance to marketing points as the main problems of milk production. Milk and butter were found to be marketed mainly through informal marketing systems. Despite the unexploited potential for milk production in the district, the existing milk production (mainly extensive) and milk marketing (mainly informal) systems are found to be interwoven by many constraints. The study indicated the need for further research and development support in areas of milk nutrition, health, input delivery and services, and product marketing in order to capitalize on the existing potential for milk industry in the district.

Key words: Bure district, marketing, milk production.

Introduction

The Amhara National Regional State (ANRS) possesses approximately 29% of the country's livestock population. The contribution of livestock to the agricultural and the total GDP of the region is estimated at 22% and 12.5%, respectively. Despite the huge potential for livestock production in the region, productivity is low. For example, the average estimated daily milk yield per cow in West Gojjam Zone of the Amhara region is

1.2 litres in 234 days of lactation period and 46,710,335 litres per lactation for all lactating cows in the zone (CSA, 2005).

Bure district, which is known as one of the surplus producing districts of the Amhara region (Yigzaw and Kahsay, 2007), is found in West Gojjam Administrative Zone of the Amhara National Regional State. Bure district is believed to have high potential for milk development. Little baseline information is available that helps designing relevant strategy for dairy development in the area. This study was intended to characterize the milk production and marketing systems in Bure district, and to identify and prioritize constraints and opportunities for the development of dairy industry in the area.

Materials and methods

Description of study area

Bure district is located in north western Ethiopia, 400 km northwest of Addis Ababa and 148 km Southwest of Bahir Dar in a mixed crop and livestock area. The district has a total area of 72,739 ha, of which 46.6% is cultivated. Altitude ranges from 713 to 2,604 meters above sea level. Agro-climatically the district has lowland (10%), mid-altitude (82%) and highland (8%). Temperatures vary from 17 to 25⁰C and total annual rainfall ranges between 1386 and 1757 mm. The topography of the district is mainly plain (76%), and 17% and 5% of the total area is rugged mountains and valleys, respectively. There are approximately 71,924 cattle, 8,294 goats, 15,225 sheep, 47,159 poultry, 6,684 equines, and 13,329 honeybee colonies in the district.

Sampling, data collection and data analysis

The survey was carried out in *Wundig, Bure town, Wangedam, Denbun, Alefa, Fatam-Sentom* and *Bekotabo* kebeles. Kebeles were selected purposively from highland, mid-altitude and lowland sites considering its potential for milk production. The target sampling population was defined as all households in the study area who owned milk cows and 10% of the households were selected randomly from a list of farmers registered as milk producers within each of the seven kebeles. Both primary and secondary data were used in

this study to characterize the milk production and marketing system of the district. The method of data collection was single-visit-multiple-subject survey. Primary data were collected by both formal and informal surveys and information was gathered by direct interviewing smallholder milk producers, butter traders, hotels owners and milk cooperatives using semi-structured questionnaire. Quantitative data were analyzed using Statistical Package for Social Science (SPSS) statistical package.

Results and discussion

Livestock type and holdings

Holding size (\pm standard deviation) for the different types of livestock in the study area is presented in Table 1. Indigenous breeds of cattle, sheep, goats and donkeys were the common livestock species kept by farmers in the area. Crossbred cattle accounted for only 7% of the total cattle herd.

Table 1. Mean livestock holdings (\pm standard deviation) per household in Bure District.

Category	Local breed		Crossbreds	
	No. of respondents	Mean \pm SD	No. of respondents	Mean \pm SD
Cattle				
<i>Oxen</i>	181	1.88 \pm 1.56	181	0.01 \pm 0.15
<i>Cows</i>	181	2.57 \pm 1.98	174	0.20 \pm 1.19
<i>Heifers</i>	180	1.25 \pm 1.38	152	0.09 \pm 0.41
<i>Bulls</i>	180	0.61 \pm 0.93	180	0.61 \pm 0.93
<i>Calves</i>	179	1.71 \pm 1.61	174	0.09 \pm 0.47
Sheep	181	2.49 \pm 4.03		
Goats	180	0.43 \pm 1.73		
Donkeys	181	0.49 \pm 0.84		
Mules	181	0.04 \pm 0.21		
Horses	181	0.02 \pm 0.15		

Milk production systems

All the milk produced and consumed is obtained from cows (from both local and crossbred cows) and there was no report of milk utilization from sheep and goats in the area due to

cultural taboo. The rural smallholder, peri-urban and urban milk production systems were identified in the district.

The rural smallholder milk production system accounted for 98% of the total milk production in the district. This is similar to the national situation (Mohamed *et al.*, 2004). In this system, the cattle herd composed of indigenous cattle breeds not specialized for milk production and kept primarily for drought purpose. Communal grazing of the native pasture, crop-residues and crop aftermaths consisted of the main feed sources for cattle and cultivation of improved forages was hardly seen in the area. The peri-urban milk production system was observed in small towns of the district. The contribution of peri-urban system to the total milk production in the district was estimated to be 1.5%. Purchased hay and *Atela* (by-product of home-made local beer and liquor) were the major feed sources. Peri-urban milk producers appeared interested in using improved dairy production interventions such as cultivating improved forages and adoption of herd health management practices. Indigenous cattle breeds were the only cattle breeds kept in this system. However, market oriented milk production is less developed. Urban milk production system was identified in Bure town (the capital of Bure district). The system using a few numbers of Holstein Friesian crossbred cattle having various blood levels. The contribution of urban milk production to the total milk production in the district was estimated to be only 0.5%. The main feed sources include purchased concentrates (wheat bran and noug seed cake) and roughages.

Husbandry practices

Purpose of keeping cattle

Livestock play multipurpose role in the mixed agricultural systems in Ethiopia (Keralem, 2005; Asaminew, 2007; Adebabay *et al.*, 2008). Drought power, food consumption (meat and milk), income generation, reproduction and transportation were the major reasons for keeping livestock in the study area (Table 2).

Table 2. Purposes of keeping livestock in Bure district.

Livestock type	Purpose				
	Draught power	Food (meat/milk)	Income	Transport	Reproduction
Cows	0.0	90.8	44.3	0.0	98.3
Oxen	96.3	8.2	21.8	0.0	13.4
Heifers	0.0	21.0	26.4	0.0	100.0
Sheep	0.0	80.0	82.4	0.0	91.8
Goats	0.0	76.5	93.8	0.0	100
Donkey	0.0	0.0	30.4	100.0	70.2
Mule	0.0	0.0	0.0	100.0	0.0
Horse	0.0	0.0	0.0	100.0	0.0

Labour

Share of responsibilities among family members in cattle husbandry in the study area is shown in Table 3. Hired labour is mainly responsible for herding and feeding of cattle. Decisions on sale of live animals and breeding are made solely by men while processing and sale of milk products are mainly the jobs of women.

Table 3. Share of responsibilities among family members in cattle husbandry activities.

Activity	Percent of responsible family members				
	Men	Women	Male children	Female children	Hired labor
Herding	10.0	1.0	35.0	3.7	50.3
Feeding	17.6	15.8	34.5	7.0	46.4
Caring of calves	21.4	22.5	27.9	11.2	28.6
Milking	52.6	36.9	8.1	4.1	8.5
Processing	0.6	88.8	2.6	14.8	2.2
Barn cleaning	10.5	39.7	20.9	27.6	16.8
Sale of milk products	6.5	71.9	7.1	10.6	6.1
Sale of livestock	93.6	10.9	1.2	1.2	1.0
Breeding decision	95.4	12.5	2.3	1.2	1.0

Feeds and feeding

From the available average land holding (1.33 ha), nearly 90% of the land holding is usually allocated for crop production and only about 5% of the land is used for pasture.

Reported improved forage production was also negligible (0.06 ± 0.14 ha). Communal grazing and stall feeding were noted to be the major feeding systems in the area. The major sources of feed identified in the study area included natural pasture, hay, crop residues, crop aftermaths and non-conventional feedstuffs such as by-products from home made beer (atella) and katikala (birint). The major crop residues in the study area are finger millet straw (30.7%), maize stover (30.1%), teff straw (24.4%), and wheat straw (1.1%). Concentrates are rarely used except by milk producers who keep crossbred cows. Generally, residues from cereals such as teff straw, wheat straw, barley straw and maize stover form the basal diets of the animals. Natural pasture, crop residue and stubble grazing are the major basal feed resources for cattle in the highlands of Ethiopia (Asaminew, 2007).

Feed shortage during January through to June was reported by 55.3% of the respondents and between July and September by 35% of the respondents while some 10% of the respondents reported year round feed shortage. In times of feed shortage, 98% of the respondents exercise conservation of crop residues, hay curing and supplementation with agro-industrial by-products or conventional feeds (2%). Only 12.8% of the respondents exercise urea treatment on teff straw (23.1%), barley straw (23.1%), wheat straw (23.1%) and millet straw (7.7%). On average, cattle trek about 0.99 km in search of water per day. The average frequency of watering local and crossbred cows and calves in the study area were 2.5 times per day.

Cattle housing and calf rearing

Cattle are housed at night in a barn or kept in open camp at grazing lands or around homestead. Crossbred cattle are housed in separate pens. 57.3% of the respondents exercise separate barn followed by open paddock at grazing lands or backyard (25.3%) and ward (4.7%).

About 68.3% of the respondents provide colostrums immediately after calving. The remaining of the respondents does not provide colostrums because they believe that it causes drying of faeces (mecoin), tongue disease, diarrhea, and stomach-ache in newly born calves. Two modes of milk feeding were noticed: restricted partial suckling and bucket

feeding. Partial suckling is the common practice (96.6%) of feeding pre-weaned local zebu calves and bucket feeding is practiced by farmers who own crossbred cows (3.4%). Calves are weaned by isolation of calves from cows (78.6%) or smearing of teats with manure (21.4%) to prepare the cow for mating.

Cattle diseases

Respiratory diseases (pneumonia), pasteurellosis, lumpy skin disease, anthrax, malignant fever, tuberculosis, blackleg, wooden tongue, trypanosomiasis and septicaemia were the major diseases reported in the area. Calving difficulties were reported by 38.2% of the respondents and the major causes included placental retention (44%), abortion (30.3%), still births (7.8%), large sized calf (3.3%), late delivery (5.8%) and dystocia (1.4%). About 86.2% of the respondents reported having access to veterinary services provided by the government (61.4%), private (4.2%), NGOs (5.4%), and both government and NGOs (12.7%). The cost of treatment for ecto- and endo-parasites was estimated respectively at ETB 8.85 and 2.68 per animal.

Pricking by thorn or spike; applying fresh manure, kerosene or fermented mud onto the skin; swabbing with lupine leaves; spraying mix of *feto* flour and honey; fumigating with human hair are some of the indigenous ethno-veterinary practices employed to control incidence of ecto parasites in livestock in the study district. Swabbing with *Calpurnia aurea* leaves is also another tradition used to heal skin diseases.

Milking and milk handling practices

Calf suckling before milking was found to be the dominant practice (97.2%) among the respondents. Only 11.2% of the respondents practice complete milking. In case of calf loss, salt rubbed calf doll is used by 28.8% of the respondents to mock-up local cows while milking.

The majority of the respondents clean their milk utensils once per day (73.2%) followed by twice (25.1%) and three times (1.7%) per day. Smoke fumigation of utensils is applied to extend the storage life of milk and milk products, and spices are used for cheese and ghee preservation while washing is common to store butter. Kega (*Rosa abissinica*), Gebre embuay (*Solanum*

indicum), Ayit hareg (*Solanecio angelatus*), Chebha (*Acacia nilotica*), Woira (*Olea africana*), Digita (*Calpurnia aurea*), Girar (*Acacia spp.*), Koke (*Prunus persica*), Tid (*Juniperus procera*), Girawa (*Vernonia spp*), Agam (*Carissa edulis*) and Enkuay (*Ximenia americana*) are plants commonly used for smoking of milk and milk products.

Milk processing and storage of milk products

Three types of containers (clay pot, plastic and steel buckets) are used for storage and processing of milk products depending on the scale and type of milk enterprise. Clay pot (*gourd*) was noted to be the major container used for milking and storing of milk products by smallholder farmers in rural areas, plastic bucket and steel bucket. *Girera*, *Kabo* and *Gurna* are the types of gourds used for milking, storage and churning of milk, respectively. In smaller towns and Bure town, plastic buckets are used for milking and milk storage, whereas clay pot, steel manual churner and gourd are used for churning. Relatively modern milk collection and churning facilities such as stainless steel buckets, plastic buckets, manual cream separators and churners were noted being used by the Bure-Damot Milk Cooperative.

Consumption and utilization of milk products

The familiar milk products produced and consumed in the study area are whole milk, sour milk, butter, buttermilk, traditional cottage cheese, whey, *Metata Ayib* and *Zure*. Among family members, children usually of below one year old have the privilege to drink whole milk. Milk is consumed in the form of boiled milk (63.2%), sour milk (14.3%) and raw milk (22.5%). Butter is used very often for home consumption (98.2%) and only 1.8% is used for sale. Buttermilk is used for both animal and human consumption (70%) and production of cottage cheese (30%).

Apart from its food value, 41% of the respondents consume milk for its alleged medicinal value. Similar beliefs were reported in other districts in northwestern (Asaminew, 2007) and Southern Ethiopia (Woldemichael, 2008). Milk and milk products reportedly used to treat various human health problems in the study area are shown in Table 4.

Table 4. Reported medicinal value of milk products in Bure district.

Health problems	Milk and milk product
Malaria	Cheese (<i>Metata ayib</i>)+whey + spices
Bloat	Butter
Ascaries	Local drug + whole milk
<i>Mich</i>	Ghee + milk (boiled)
Stomach discomfort	Butter + yoghurt

Marketing of milk and milk products

Informal marketing was the main system for milk and butter marketing in the study area. Milk producers reported marketing of surplus milk and butter to consumers, retailers and cooperatives. The cash obtained is used to buy food and non food items (clothing and education expenses) for children (82.4%). However, purchasing of farm inputs using the sales income (breeding cows, feed, fertilizer and seed) was fairly low (17.6%).

Milk marketing channels and chains

Whole milk, butter, *ergo* (fermented whole milk), cheese and buttermilk were the marketable commodities reported. The key participants identified in the milk market include milk producers, milk cooperatives and consumers while, milk producers, a cooperative, intermediate traders and consumers were identified as key participants in the butter market. The **Producer** → **Consumer** channel (predominant in Alefa and Bure town) accounts for 48.3% of the total milk marketed per day followed by the **Producer** → **Cooperative** → **Consumer** channel (40.6%) which was exceptional to Bure town. Eleven percent of the total milk marketed in the district follows the **Producer** → **trader** (hotels, tea kiosks) channel. The relatively short milk marketing channel observed in this study compared to the findings by Woldemichael (2008) might be advantageous in lowering consumer prices and increasing return to producers.

Butter marketing was undertaken mainly through the **Producer** → **Consumer** channel which involves direct sale of butter to consumers around the farm gate and in local market places. This channel represented the shortest in terms of intermediaries and smallest in terms of volume of butter and value. Consumers who usually buy butter for cosmetics

purpose rather than for food are categorized in this channel. Butter for consumption is mostly purchased in markets where there is better supply of butter in terms of quality and quantity with ample bargaining alternatives. **Producer** → **Retailer** → **Consumer** channel is also another route exercised at Bure and Kuch Saturday markets. In this channel retailers buy butter from the market and sell in the same market to make some profit.

Table 5. Reported milk and butter buyers, and mode of payment in Bure district.

Category	N	Percent
Milk buyers		
Consumers	140	48.3
Traders (hotels, teashops)	2	6.9
Cooperatives	23	44.8
Butter buyers		
Consumers	124	66.4
Retailers (hotels and traders)	51	30.6
Mode of payment		
Cash	164	98.4
Cash in advance	12	1.6
Market outlets (milk)		
Farm gate/homestead	15	19.0
Market place	48	60.8
Door to door delivery	16	20.2
Market outlets (butter)		
Farm gate/homestead	30	16.9
Market place	120	67.8
Door to door delivery	27	15.3

Determinants of price, demand and supply of milk products

Various factors were noted affecting price, demand and supply of milk and milk products in Bure district similar to Southern Ethiopia (Sinayehu *et al.*, 2008). These included: season (dry versus wet), distance to market points, fasting periods, festivals and holidays.

Yield and supply of milk and milk products per household and per animal increased during the wet season due to better availability of feed stuff. Demand and price of milk and milk products increased in non-fasting periods, festivals and holidays. During fasting periods, greater proportion of fresh milk was processed into butter. Distance to market was also another determinant of demand, supply and price of milk products in Bure district. Producers of Bure travel on average 0.62 km to sell milk and milk products (Table 6). Milk produced in remote rural areas of Bure district is often sold in the form of butter.

Table 6. Reported prices of milk and butter and distance to market points in Bure district.

Variables	N	Mean \pm SD	Minimum	Maximum
Price of milk per litre	26	4.00 \pm 0.83	3.50	4.00
Price of butter per kg	52	39.08 \pm 8.82	20.00	65.00
Distance travelled to sell milk (Km)	26	0.62 \pm 0.88	0.00	4.00
Distance travelled to sell butter (km)	62	6.33 \pm 5.11	0.00	20.00
Transport cost per round trip (ETB)	30	8.30 \pm 18.12	0.00	10.00

Constraints to milk production and processing

Milk production constraints

The reported constraints to milk production in the area are feed shortage, animal health problems together with poor veterinary services and weak breeding services (Table 7). The utmost constraint is the lack of grazing/feed resources due to limited land. The study area has a heavy human and animal population density and communal grazing lands are very rare in the area, worsened by poor feeding system and unavailability of agro-industrial by products. The study area has a nine month dry season and only a three month rainy season. Grazing is extremely scarce during the dry season causing many animals to eat such materials that have little nutritional value. Problems of seasonal availability of roughage feeds could be minimized through conventional feed conservation practices like hay and silage making and straw treatment to ensure sustainable supply of roughage feeds throughout the year.

Health problems were reported as the second important constraint. Poor delivery of veterinary services was cited by some farmers. Regarding dairy cattle breeding, unavailability of crossbred heifers, inefficient AI service and lack of community bull service were reported. Inadequate access to water particularly during the dry season was identified by farmers. Livestock had to trek on average 5 km in search of drinking water. Infestation of rivers and ponds by leech (*alekit*) is a very serious problem. Little intensive management is exercised by few of the milk production farms. Lack of skills in improved milk cattle management systems had negative impact on milk production system in the area. There are hardly any cooperative for milk production except at Bure. The study highlighted milk producers had little or no access to credit. Organizing collective groups such as milk producers and marketing cooperatives and implementing recommended support services, problems of availability and affordability of inputs (drugs and concentrate feeds) could well be resolved.

Table 7. Reported frequency of major constraints to milk production (N = 181).

Constraints	N	Proportion (%)
Shortage of feed	86	47.5
Animal health problems (diseases and parasite infestation)	58	32.0
Lack/inadequate supply of improved dairy cattle	19	10.5
Inadequate access to water	12	6.6
Poor veterinary services (lack of surveillance of disease outbreaks)	6	3.3

Marketing constraints

A number of marketing constraints that hinder the development of improved dairy industry were identified in Bure district. Milk producing households reported that seasonal variations in price, demand and supply of milk as one of the problems in milk marketing. Seasonal fluctuations in demand of milk products due to long fasting periods was found to be the major bottleneck in both milk production and marketing in Bure where the Orthodox Christianity is predominant (97.8%). Lack of milk processing plants in the area contributed to problems currently prevailing in the milk shed. Processing technologies which could extend the shelf life of milk products may resolve the problem of seasonality in demand for milk and milk products. Distance to marketing points (67.9%), lack of training related to

milk product marketing (24.9%) and adulteration of milk (7.2%) were problems reported by dairy producers of the area. For potential milk areas, where there is no market access, a milk collection scheme through establishment of milk marketing groups may alleviate the problem. Moreover, training on market-oriented milk production and marketing issues should be provided to extension officers.

Conclusion and Recommendations

The study showed that the existing milk production systems (mainly extensive) & marketing (mainly informal) systems are interwoven by many constraints related to feed, nutrition, health, breed, breeding practice, handling, processing and marketing of products predominates in the study district.

In general, the milk industry is at its infant stage compared to the existing potential of the area for milk production. The marketing system in the area was characterized by under developed and inefficient type of market for both milk and butter. The current situation regarding access to milk production services was not encouraging. Extension service in improved milk production (AI, veterinary services, introducing improved cattle breeds), credit and market information appeared very weak.

Therefore, strong technical and institutional support is required to promote intensive milk production systems and develop formal milk and milk product marketing systems in Bure district. Further work is needed specifically in areas of nutrition, health, milk and milk product marketing, input delivery & services to capitalize market oriented milk industry in the district.

References

Adebabay Kebede, Keralem Ejigu, Tessema Aynalem and Abebe Jenberie. 2008. Beekeeping in the Amhara region. Available on <http://WWW.eiar.gov.et>.

- Asaminew Tassew. 2007. Production, handling, traditional processing practices and quality of milk in Bahir Dar milk shed Area, Ethiopia. M.Sc. Thesis. Alemaya University, Ethiopia.
- CSA (Hawassa Central Statistical Agency). 2005. Federal Democratic Republic of Ethiopia Agricultural Sample Survey. Livestock and livestock characteristics bulletin, Volume II. Addis Ababa, Ethiopia.
- Keralem Ejigu. 2005. Honeybee production systems, opportunities and challenges in enebse Esar midir wereda (Amhara region) and Amaro Special Wereda (Southern Nations, Nationalities and Peoples Region), Ethiopia. M.Sc. Thesis, Alemaya University, Ethiopia.
- Mohamed, A.M.A., Simeon, E., and Yemesrach Assefa. 2004. Milk development in Ethiopia. EPTD Discussion Paper No. 123. Washington DC, U.S.A.
- Sintayehu Yigrem, Fekadu Beyene, Azage Tegegne and Berhanu Gebremedhin. 2008. Dairy production, processing and marketing systems of Shashemene–Dilla area, South Ethiopia. IPMS (Improving Productivity and Market Success) of Ethiopian Farmers Project Working Paper 9. ILRI (International Livestock Research Institute), Nairobi, Kenya. 62 pp.
- Yigzaw Desalegne and Kahsay Berhe. 2007. Bure pilot learning district diagnosis and program design. Unpublished.
- Woldemichael Somano. 2008. Milk marketing chains analysis: The Case of Shashemane, Hawassa and Dale district's milk shed, Southern Ethiopia. M.Sc. Thesis. Hawassa University, Ethiopia.

Production system and linear body measurements of Washera sheep in the Western highlands of the Amhara National Regional State, Ethiopia

Mengistie Taye¹, Markos Tibbo², Girma Abebe³, Solomon Gizaw⁴, Sisay Lemma⁴ and Abebe Mekoya⁴

¹Andassa Livestock Research Centre, P.O.Box 27, Bahir Dar, Ethiopia; ²International Center for Agricultural Research in the Dry Areas, P.O.Box 5466, Aleppo, Syria; ³Hawassa University, P.O.Box 5, Awassa, Ethiopia;

⁴Debreberhan Agricultural Research Centre, P.O.Box 112, Debre Berhan, Ethiopia

Abstract

A study was conducted to describe the production systems and the linear body measurements of Washera sheep in the northwestern highlands of Ethiopia. Data was collected using focus group discussion and field measurements. Washera sheep are kept by smallholder farmers in a mixed crop-livestock system. The major source of feed for sheep is communal pasture. Sheep are housed at night together with other livestock separated by woodlot. Mating is year round. Docking the fat tail of ewe lambs is a common practice. The average flock size per household obtained in the present study was 9.58 sheep. The sheep flock on average was composed of 52.2% young stock with milk teeth, 9.9% sheep with 1 pair of permanent incisors (PPI), 8.3% with 2 PPI, 5.2% with 3 PPI and 24.3% with 4 PPI and above. The overall body weight, wither height, body length, heart girth, pelvic width and ear length were 26.69±0.45 kg, 68.96±0.36 cm, 57.66±0.33 cm, 74.37±0.49 cm, 14.34±0.12 cm and 9.73±0.08 cm, respectively. The fixed effects of district, sex, dentition and the interaction between sex and dentition were sources of variations for most of the measured variables. The high correlation coefficients observed between body weight and heart girth for all dentition groups suggested heart girth alone or in combination with other body measurements could be used to predict live weight of Washera sheep. Differences in coefficient of determination of equations fitted for different dentition groups indicated that weight could be estimated using different equations for different age groups with different accuracies.

Key words: Heart girth, linear body measurement, traditional farming systems, Washera sheep.

Introduction

Ethiopia with its extremes of variable agro-climatic conditions and ecological systems is endowed with 21 million heads of sheep (CSA, 2003) categorized into 18 diverse populations (Tibbo, 2006). Among these diverse sheep populations, Washera sheep is found in the Western highlands of the Amhara National Regional State (Sisay, 2002). The

breed has a population of around 1.22 million (CSA, 2006) and are one of the most productive breeds (Chipman, 2003). Washera sheep also called Dangla is characterized by large body size, wide fat-tail usually curved upward tip, horizontally carried or semi-pendulous long ears, both sexes hornless and slightly concave facial profile. These sheep have long and thin legs, long neck, and prominently protruding brisket. Plain, patchy and spotted patterns of coat colour to which reddish brown with white patches or spots usually on the forehead and lower parts of the legs, plain reddish brown and plain white are dominant colour types (Sisay, 2002).

A primary procedure for any future improvement in genetic resource utilization and conservation is to describe the breed/type and its production system. Information on the description of body measurements of Ethiopian indigenous sheep in general and Washera sheep in particular is scanty. The objective of the study was, therefore, to collect data on the production system and morphological characters of Washera sheep kept under the traditional management system of the northwestern highlands of Ethiopia.

Materials and methods

The study area

The study was conducted on on-farm flocks in two districts in the northwestern highlands of Ethiopia. The first district, Yilmanadensa, is located between 11°10'-11°15'N and 37°30'-37°40'E. The second district, Quarit, is located between 11°00'N and 37°20'-37°30'E. The study districts and flocks were selected purposively to superimpose on the ongoing project entitled '*Community- and Conservation-based Improvement Scheme (program) for Washera Sheep*'. Both of the study areas are situated at an altitude range of 1500 to >3000 m above sea level. The study areas have one rainy season, which extends from mid May to October and all the remaining months (November to mid May) are dry. Estimated average minimum and maximum air temperatures in the two districts are 13 and 24 °C, respectively (ENMA, unpublished).

Data collection and analysis

Data was collected in August 2007. Participatory rural appraisal (PRA) with a focus group discussion was used to investigate and understand the general sheep production system of the area. A check list focused on the major agricultural system, major crops produced, major livestock produced, and sheep production (management and marketing, feeds and feeding, reproduction management) was used.

For the morphological study, all sheep (N = 650) in the study flock above nine month of age were measured. The live weight of an animal was measured using a Salter scale (50 kg capacity with 200 gram precision). Other body measurements (heart girth, wither height, body length, pelvic width and ear length) were measured using flexible metal tape (3 meter length) to the nearest 0.5 cm after restraining and holding the animals in an unforced position. Heart girth was measured as the circumference of the chest posterior to the forelegs at right angles to the body axis. Wither height was recorded as the highest point measured as the vertical distance from the top of the shoulder to the ground (bottom of forelegs). Body length was measured as the horizontal length from the point of shoulder to the pin bone. Pelvic width was recorded as the horizontal distance between the extreme lateral points of the hook bone (*tuber coxae*) of the pelvis. Ear length was recorded as the length of the external ear from its root to the tip (Figure 1).

Analysis of variance of fixed effects of location, sex and dentition on body measurements were done by the General Linear Model procedures of Statistical Analysis System (SAS version 9.1). The statistical models used were:

$$Y_{ijk} = \mu \pm D_i \pm S_j \pm (DS)_{ij} \pm e_{ijk} \dots \dots \dots \text{Model 1}$$

$$W = a \pm bG \text{ (linear)} \dots \dots \dots \text{Model 2}$$

$$W = a \pm b_1G_1 \pm b_2G_2 \pm \dots \pm b_nG_n \text{ (Multiple linear)} \dots \dots \dots \text{Model 3}$$

Where, Y_{ijk} = The observation on body weight, wither height, heart girth, body length, pelvic width, ear length; W = The observation on live weight of the animal; μ = Overall mean; D_i = Fixed effect of district (i= Yilmanadensa, Quarit); S_j = Fixed effect of lamb sex (j = Female, Male); $(DS)_{ij}$ = the interaction effect of district with sex; a = Intercept; b =

Regression coefficient of weight on body measurements; G = Body measurements; $n = n^{\text{th}}$ number of body measurement; e_{ijk} = effect of random error.

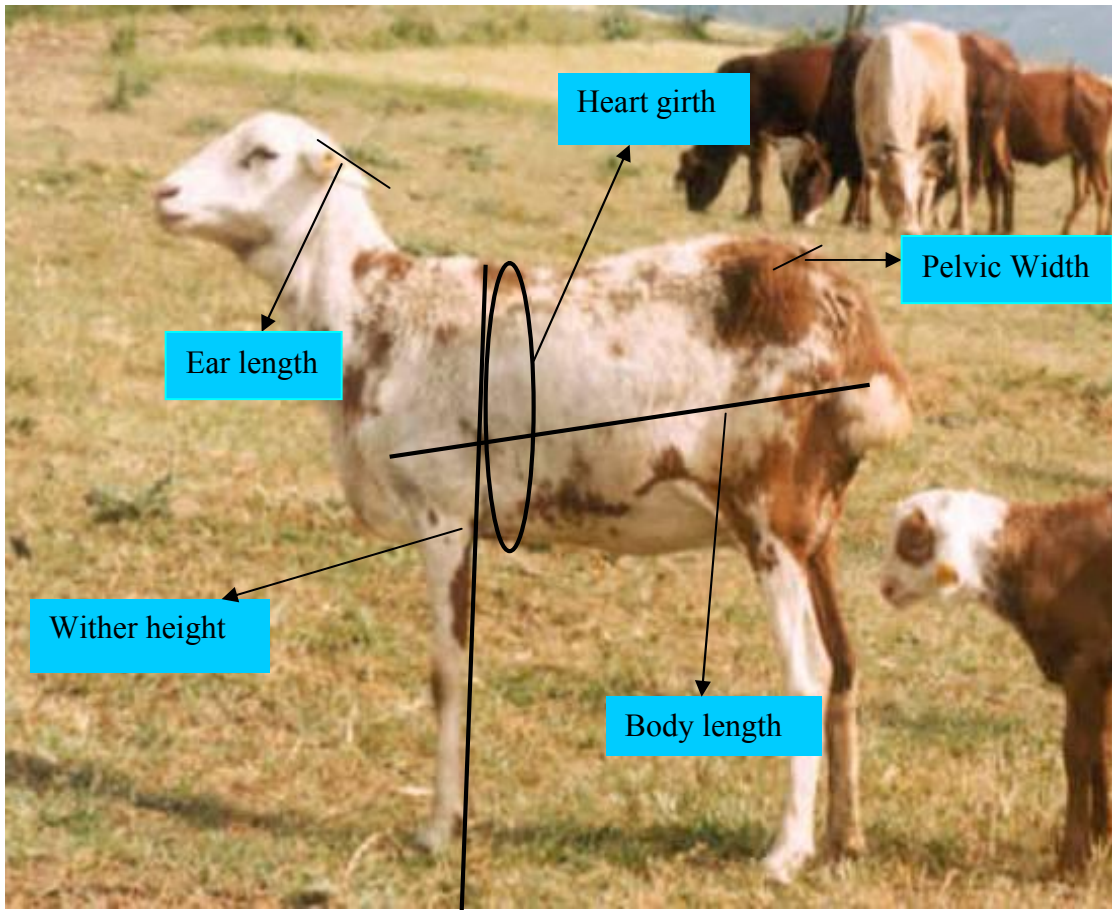

Figure 1. Washera ewe showing the exact points at which the measurements were taken.

For the analysis of fixed effects of linear body measurements model 1 was used. For all linear measurements dentition was grouped as 0-sheep with milk teeth (above 9 months); 1-sheep with one pair of permanent incisor (PPI); 2-sheep with two PPI; 3-sheep with three PPI; 4-sheep with four PPI and above. For the prediction equation of weight using body measurements, models 2 (linear) and 3 (multiple linear) were used. The statistical analysis was carried out using SPSS (SPSS version 13.0) linear regression procedures. Live weight was regressed on body measurements separately for different age groups and for overall. In the multiple regression equation, prediction equations were developed for live weight using

a stepwise multiple regression procedure in which the number of predictors to be selected and the order of entry are both decided by statistical criteria (Field, 2005).

Results and discussion

Description of the production system

The agricultural production system in the study area was mixed crop-livestock. Crop production was the main agricultural activity in both study areas. The major crops grown include teff, maize, chickpea, barley, grass pea, field pea, faba bean and wheat. Cattle, sheep, donkey and poultry were main livestock species reared by the farm household. Some people practiced apiary. Cattle were mainly kept for draft power (ploughing) from oxen and production of oxen and small milk from cows. Sheep and poultry were kept for cash income (sale) and for home consumption. Livestock production and crop production complement each other in such a way that livestock are used as a source for draft and manure for crop production and from crop production the crop residues, straws and aftermath serve as main components of livestock feeds in the study areas. This type of complementarities in mixed crop-livestock production systems is well stated in the literature (Getahun, 2008).

Livestock graze on a communal grazing land which is owned by about 10 farmers (the area of land and number of households varies from area to area) and on crop aftermath. Most farmers own private grazing land for morning and afternoon grazing. Shrinkage of the communal grazing land from time to time due to cultivation and increased population pressure are the critical and major threats in addition to land slide and erosion (gully) in the highlands of Ethiopia (Getahun, 2008; Mengistie, 2008).

Though sheep production contributes in the household income to a great extent, it has long been taken as a side activity. However, the trend is that due to the decreasing grazing land and increasing population pressure, sheep are becoming very important and increasing from time to time. During focus group discussion, the key informants did mention that because

of their suitability to produce and reproduce under feed shortage and with the increased market value, sheep are getting more attention in the present days.

Sheep production and management

Feeding: Sheep are herded together with other livestock species during the day. Like other parts of the highlands of the country, the main feed source is communal grazing land, crop residue and crop aftermath (Abebe, 1999; Getahun, 2008; Tesfaye, 2008). During crop harvesting season and in the afternoon, farmers remove their animals from the group-flock and graze them in their respective private grazing land and crop aftermath. Sheep had no access to hay and straw collected for dry season feeding. Now-a-days some farmers in the study areas are recognizing the difference of supplementing or not supplementing during feed shortage times. Priorities are given to pregnant, suckling and castrated animals when supplementing. The supplements are grass-pea straw, sprouted bean, local brewery byproduct “*atela*” and salt.

Housing: Farmers in the study area house their sheep throughout the year to protect them from cold and rain, predators and theft. The housing is usually together with other livestock to which it is separated by a fence. But some farmers with large flock size constructed separate house for their sheep. In both cases it is usually built adjacent to the family house. Some farmers with small flock size tie their sheep to a peg. According to the respondents, there is a difference in the productivity of sheep between those tied and housed freely where tied animals were healthier and productive than those housed freely. Farmers explained this as sheep housed freely lay one over each other because of their social behaviour and also in need of the warmth from huddling. Pregnant animals, young lambs and weak animals are the most vulnerable groups. In addition, animals may not get enough rest at night.

Newborn lambs in the first week of birth are separated from their dam and cared for at home during the day when sheep are taken to grazing and before they get into their house upon their return in the afternoon. This is a common practice in other parts of the country (Mengistie, 2008; Tesfaye, 2008; Abebe, 1999). Farmers use large baskets to keep newborn

lambs; allow lambs to be kept dry, clean and warm. Suckling is in the morning before the dam leaves for grazing and when the flocks are back from grazing in the afternoon. Some farmers do separate even the dams for at least the first week of parturition and provide care for both lambs and dams indoors. These increase the dam-lamb relationship and help to protect the lamb from chill, sun and other environmental stresses thereby increase lamb survival (Mukasa-Mugerwa *et al.*, 2000).

Disease prevalence and control: There is less disease load in the study areas. Nonetheless, occasionally there might be disease outbreak during which many sheep would die because of lack of health support. Some of the symptoms of diseases in the area mentioned were death, shivering, coughing, diarrhea, bloating, haemorrhage and wound around ear and mouth and legs, loss of appetite, mucus and frowsy mouth, dropping ear and head. Apart from taking to health clinics, farmers treat their animals by drenching the juice of different herbs, bleeding on its ear and ironing and puncturing the abdomen when bloating. But, most of the time they die. Abortion was an important problem of sheep production. Fearing of these, many farmers are reluctant to keep as many sheep as they need.

Reproduction: Reproduction is year-round to which most lambing concentrate in some of the months (August and February). This is true for any other breeds of sheep in Ethiopia (Getahun, 2008; Girma, 2008). Mating was uncontrolled: any ram in the flock would mate with any in-heat ewe. There is a problem of breeding ram; ram lambs were sold before reaching puberty. If any, those are of poor conformation to be sold at the market. In fact, some farmers had their own ram tied at home and a farmer does not allow his ram to mate other farmers' ewes.

Docking: Cutting the fat tail of female sheep is a common practice in both study areas. Sisay (2002) reported that more than half of the breeding females in the Western highland sheep were docked. There is no standardized specific site of cutting. The practice is that almost all of the fat tail would be cut (Figure 2). This is intended to ease mating and improve conception rate, improve body condition and not least to use the cut tail for

consumption while the sheep are still alive. The cutting is done at the age of 2–3 months of age, after weaning. Farmers use hot sharp knife to avoid bleeding and infection.



Figure 2. Docked ewe lamb (left), weaning method (right) in the study areas.

Weaning: There is no formal weaning and weaning age. But when suckling is prolonged and if lambs are of good body condition, farmers wean their sheep by covering the udder of the dam with a piece of cloth (Figure 2), smearing the teat with dung and separating the dam from the lamb. This is usually done after three months of age of the lamb.

Culling: Culling is not common in the study area. Old ewes are maintained for long period of time even to the 12th parity. Ewes can be kept with no production for years. Farmers do not want to sell or slaughter those sheep that serve the family. But today, this type of sheep management is changing.

Castration: Castration of sheep is not a common practice in the study areas. Some farmers with better wealth status, however, castrate and fatten two to three castrates for long period (1-2 years) for home consumption as well as for market. The method of castration is traditional by repeatedly crushing the cord above the testis using a smooth river-stone and wood. The age of castration is not fixed, but it is usually after the one pair of permanent incisors is seen. This is because farmers believed that the rams will mature and finish growth at this age.

Marketing: Though sheep are sold anytime in a year and as cash needed, most are sold during holidays. Most ewe and ram lambs are sold just at weaning before they lose condition because of weaning shock. It is the ram lambs that are usually sold for meat at the market. Ewe lambs are sold for reproduction at the village level. Ewe lambs of healthy and better producing flock can be sold (pre-paid with better price) even earlier than two weeks of age by convention between the owner and buyer to take at weaning. This is to have better producing genotype. Through this they are selecting the flock for good. But, un-deliberately they are selecting the flock negatively through the drain of fast-growing good genotype ram lambs. This is because those good looking with high growth ram lambs are sold out from the flock before they reach breeding age. Since there is no controlled breeding, ram lambs which are not sold because of poor growth and conformation has chance to mate the flock.

In both areas, there is a nearby market to sell their sheep and there is a trend of marketing within the village (especially for breeding purpose). Market access was not mentioned as a problem in the study areas.

Flock size and demography

The average flock size per household and flock composition by age and sex in the study is presented in Table 1. The average flock size per household obtained in the present study was 9.58 sheep. Flock size ranged from 1 to 29 heads of sheep. A similar result was reported for the same sheep at Quarit (Chipman, 2003). The average holding of sheep (9.58) was higher than the 5.0 sheep/household reported from Alaba areas (Tsedeke, 2007) and the 6.97 sheep/household around Dire Dawa (Aden, 2003). However, it is lower than the 16.02 sheep/household in Gumuz sheep (Solomon, 2007), and 24 sheep/household in Lallo Mama Midir in the central highland of Ethiopia (Abebe, 1999).

Flock composition in terms of sex and age classes has been taken as an indicator of the management system that reflects to some degree the management objective, flock productivity and constraints on the system (Ibrahim, 1998). In the present study, the total flock composition (%) was 52.2, 9.9, 8.3, 5.2 and 24.3, young stock with milk teeth, sheep

with 1 PPI, 2 PPI, 3 PPI and 4 PPI and above, respectively (Table 1). From the young stock, 60.2% were females, 38.7% males and the rest 1.1% were castrates. This suggests that since a 1:1 male to female ratio is expected, more ram lambs were already sold from this age group.

Of the total flock, 76.4% were females of which 58.8% were breeding ewes with at least one PPI and 31.6% were old ewes with four PPI and above. This higher proportion of old breeding ewes indicates that farmers in study area maintain breeding ewes for long period of time and the importance of culling. Males and castrates constitute 21.8% and 1.8%, respectively. More than 92% of the non-castrated males and 32% of the castrates were with milk teeth. The present study is in close agreement with the CSA (2003) report obtained in the Amhara region with 74.1% females and 25.9% males from the total flock. Sisay (2002), who studied sheep flocks under the traditional systems in Amhara region reported exactly similar results of 76.39% females and 23.61% males.

Table 1. Average flock size and flock composition by sex and dentition groups.

Sex	Dentition group ¹										Total	
	0		1		2		3		4			
	No	%	No	%	No	%	No	%	No	%	No	%
Male	208	20.2	4	0.4	4	0.4	7	0.8	2	0.2	225	21.8
Female	324	31.4	89	8.6	79	7.4	46	4.5	249	24.2	787	76.3
Castrate	6	0.6	9	1	3	0.4	1	0.0	0.0	0.0	19	1.8
Overall	538	52.2	102	9.9	86	8.3	54	5.2	251	24.3	1031	100

¹Dentition: 0 = sheep with milk teeth, 1 = sheep with 1 PPI, 2 = sheep with 2 PPI, 3 = sheep with 3 PPI, 4 = sheep with 4 PPI and above.

Linear body measurements

Body measurements of Washera sheep are presented in Table 2. The overall body weight, wither height, body length, heart girth, pelvic width and ear length obtained were 26.69±0.45 kg, 68.96±0.36 cm, 57.66±0.33 cm, 74.37±0.49 cm, 14.34±0.12 cm and 9.73±0.08 cm, respectively.

Table 2. Linear body measurements of Washera sheep by district, sex and dentition.

Variable	N	Wither		Body length	Heart girth	Pelvic width	Ear length
		Weight (kg)	height (cm)	(cm)	(cm)	(cm)	(cm)
		LSM±SE	LSM±SE	LSM±SE	LSM±SE	LSM±SE	LSM±SE
Overall	650	26.69±0.45	68.96±0.36	57.66±0.33	74.37±0.49	14.34±0.12	9.73±0.08
District		***	***	NS	**	***	NS
Yilmanadensa	377	26.03±0.47	69.59±0.38	57.55±0.35	73.87±0.51	14.21±0.12	9.76±0.08
Quarti	273	27.34±0.47	68.34±0.38	57.76±0.35	74.87±0.51	14.47±0.12	9.71±0.08
Sex		***	***	*	**	NS	NS
Male	58	28.33±0.88	70.79±0.71	58.34±0.65	75.65±0.95	14.24±0.23	9.67±0.15
Female	592	25.04±0.18	67.14±0.14	56.98±0.13	73.09±0.19	14.44±0.05	9.80±0.03
Dentition		***	***	***	***	***	NS
0	146	19.79±0.33 ^c	63.99±0.27 ^b	52.72±0.25 ^c	66.28±0.36 ^d	12.59±0.09 ^d	9.61±0.06
1	105	25.56±1.09 ^b	69.71±0.88 ^a	56.96±0.81 ^b	72.82±1.19 ^c	14.05±0.29 ^c	9.88±0.19
2	95	27.45±1.09 ^{ab}	70.1±0.88 ^a	58.69±0.81 ^{ab}	75.08±1.19 ^{bc}	14.47±0.29 ^{bc}	9.73±0.19
3	55	30.19±0.87 ^a	71.43±0.70 ^a	59.40±0.65 ^a	77.88±0.95 ^{ab}	15.17±0.23 ^{ab}	9.49±0.15
4	249	30.43±1.32 ^a	69.58±1.07 ^a	60.52±0.98 ^a	79.79±1.44 ^a	15.42±0.35 ^a	9.97±0.23
Sex xDentition		**	***	*	***	NS	NS
Male x 0	45	19.52±0.56 ^c	63.74±0.45 ^c	52.24±0.41 ^c	65.22±0.60 ^e	12.22±0.15	9.55±0.10
Male x 1	3	27.61±2.16 ^{bcd}	73.07±1.74 ^a	57.90±1.60 ^{ab}	74.28±2.34 ^{bc}	13.98±0.56	10.08±0.38
Male x 2	3	29.18±2.15 ^{abc}	72.63±1.73 ^a	59.65±1.60 ^a	76.17±2.34 ^{ab}	14.27±0.56	9.63±0.38
Male x 3	5	33.05±1.67 ^a	74.51±1.34 ^a	60.41±1.24 ^a	80.33±1.81 ^a	15.24±0.44	9.09±0.29
Male x 4	2	32.30±2.64 ^{ab}	70.00±2.12 ^{ab}	61.50±1.96 ^a	82.25±2.86 ^a	15.50±0.69	10.00±0.47
Female x 0	101	20.06±0.37 ^c	64.25±0.30 ^c	53.20±0.28 ^c	67.34±0.40 ^d	12.96±0.10	9.66±0.07
Female x 1	102	23.51±0.37 ^d	66.35±0.30 ^b	56.03±0.27 ^b	71.35±0.40 ^e	14.13±0.10	9.68±0.07
Female x 2	92	25.73±0.39 ^{cd}	67.61±0.31 ^b	57.74±0.29 ^{ab}	73.99±0.42 ^{bc}	14.68±0.10	9.82±0.07
Female x 3	50	27.34±0.53 ^{bcd}	68.34±0.43 ^b	58.39±0.39 ^a	75.43±0.57 ^b	15.10±0.14	9.90±0.09
Female x 4	247	28.56±0.24 ^{bc}	69.16±0.19 ^b	59.53±0.18 ^a	77.33±0.26 ^a	15.34±0.06	9.94±0.04

¹Dentition is same as in Table 1. NS, *, **, ***, and **** denote non significant and significant differences at $p < 0.05$, $p < 0.01$, $p < 0.001$, and $p < 0.0001$ probability levels, respectively.

The overall body weight (26.69±0.45 kg) obtained were smaller than the report for the mature Western highland sheep by Sisay (2002), while it was in close agreement with Horro and Menz sheep at 12 and 24 months of age (Tibbo *et al.*, 2004). Fixed effects district, sex and dentition were significant ($p < 0.001$) sources of variation for body weights. Sheep from Quarit, male sheep and old aged sheep were superior in weight than Yilmanadensa sheep, female sheep and young aged sheep (with dentition <2 PPI), respectively. The effect of district may be because of the differences in the management of sheep between the districts. The superiority in the weight of males over females could be because of the hormonal differences in their endocrinological and physiological functions

(Ebangi *et al.*, 1996). Tibbo *et al.* (2004) also reported the effect of sex on the weight of Horro and Menz sheep. The interaction effect of sex with dentition significantly ($p < 0.01$) affected body weight where male and old aged (dentition 2, 3, 4) sheep were heavier than other groups of sheep.

Height at wither (68.96 ± 0.36 cm) was significantly ($p < 0.001$) affected by district, sex, dentition and the interaction between sex and dentition. Yilmanadensa sheep were superior in height at wither over their Quarit counterparts. Males with dentition above 1 PPI were taller than other sex and dentition groups. This might be because growth continues to a certain age until bone growth stops. The value obtained is in comparison with the value reported Sisay (2002) for mature western highland sheep. However, it is greater than that of Horro and Menz sheep at 12 and 24 months of age (Tibbo *et al.*, 2004).

Sex, dentition and the interaction effect of sex with dentition were important sources of variation in body length. Females and sheep with dentition 0 were shorter ($p < 0.05$) in body length than males and sheep with higher dentition groups.

Sheep at Quarit were superior ($p < 0.01$) in heart girth than Yilmanadensa sheep. Sex also affected heart girth that males had higher ($p < 0.01$) heart girth than their female counterparts. With respect to the effect of age, sheep with dentition 4 were superior ($p < 0.001$) over their dentition 0 counterparts. Similarly, the interaction effect of sex with dentition was highly significant ($p < 0.001$) where females with four PPI and males with four, three and two PPI were superior over other sex and dentition interaction groups. Pelvic width was also variable among districts. Quarit sheep had wider ($p < 0.001$) pelvis than Yilmanadensa sheep. Dentition group significantly influenced pelvic width where pelvic width increased with age of sheep.

Prediction of body weight

The Pearson's correlation of linear body measurements with weight and with each other is presented in Table 3. The observed positive and significant ($p < 0.01$) correlations between weight and other body measurements were in agreement with literature (Kassahun, 2000;

Thiruvenkadan, 2005; Afolayan *et al.*, 2006; Sowande and Sobola, 2007; Hamayun *et al.*, 2006).

Table 3. Phenotypic correlations between body weight and other body measurements in Washera sheep.

Dentition ¹		BW ²	WH	BL	HG	PW
0 PPI	WH	0.672**				
	BL	0.775**	0.761**			
	HG	0.857**	0.786**	0.791**		
	PW	0.690*	0.695**	0.689*	0.803*	
	EL	0.065 ^{NS}	0.239**	0.155 ^{NS}	0.175*	0.309**
1 PPI	WH	0.494**				
	BL	0.585**	0.641**			
	HG	0.783**	0.523**	0.617**		
	PW	0.486**	0.281**	0.473**	0.527**	
	EL	0.197*	0.334**	0.171 ^{NS}	0.201*	0.231*
2 PPI	WH	0.518**				
	BL	0.653**	0.498**			
	HG	0.754**	0.543**	0.462**		
	PW	0.515**	0.192 ^{NS}	0.493**	0.311**	
	EL	-0.084 ^{NS}	0.052 ^{NS}	0.135 ^{NS}	-0.077 ^{NS}	0.207*
3 PPI	WH	0.581**				
	BL	0.453**	0.403**			
	HG	0.828**	0.628**	0.323*		
	PW	0.513**	0.391**	0.110	0.548**	
	EL	-0.129 ^{NS}	-0.047 ^{NS}	0.059 ^{NS}	-0.092 ^{NS}	0.010 ^{NS}
4 PPI	WH	0.421**				
	BL	0.492**	0.372**			
	HG	0.798**	0.445**	0.399**		
	PW	0.448**	0.353**	0.300**	0.501**	
	EL	0.103 ^{NS}	0.127*	0.149*	0.125*	0.200**

¹Dentition is same as in Table 1. ²BW = Body weight, HG = Heart girth, PW = Pelvic width, BL = Body length, WH = Height at wither, EL = Ear length. NS, *, and ** denot non significant difference and significant difference at $p < 0.05$ and $p < 0.01$, respectively.

Among the body measurements heart girth had the highest correlation coefficient with weight at all dentition groups. The correlation coefficient between weight and heart girth was highest at dentition group 0 PPI. Similarly, the highest correlation between weight and wither height, body length and pelvic width was found at dentition group 0 PPI. The high correlation coefficients observed between body weight and heart girth for all dentition groups suggest that heart girth alone or in combination with other body measurements could provide a good estimate of predicting live weight of Washera sheep at different dentition groups.

Parameter estimates of linear and multiple linear regression equations predicting live weight from body measurements of Washera sheep are presented in Table 4. It was found that all the fitted equations were good at estimating weight from body measurements ($R^2 = 0.58$ to 0.82). Heart girth alone was better in estimating weight ($R^2 = 0.58$ to 0.73).

Table 4. Regression models for predicting body weight of Washera sheep at different age groups.

Dentition ¹	Model ²	<i>a</i>	<i>b</i> ₁	<i>b</i> ₂	<i>b</i> ₃	<i>R</i> ²	<i>R</i> ² Change	Std error
0	$a \pm b_1 \text{HG}^*$	-23.160	0.646			0.735	0.000	1.913
	$a \pm b_1 \text{HG} \pm b_2 \text{BL}$	-27.620	0.492	0.278		0.759	0.025	1.828
1	$a \pm b_1 \text{HG}$	-30.493	0.756			0.613	0.000	2.305
	$a \pm b_1 \text{HG} \pm b_2 \text{BL}$	-36.071	0.658	0.224		0.629	0.017	2.266
	$a \pm b_1 \text{HG}$	-31.405	0.771			0.578	0.000	2.368
2	$a \pm b_1 \text{HG} \pm b_2 \text{BL}$	-47.734	0.592	0.513		0.694	0.116	2.028
	$a \pm b_1 \text{HG} \pm b_2 \text{BL} \pm b_3 \text{PW}$	-52.066	0.571	0.398	0.855	0.722	0.028	1.944
3	$a \pm b_1 \text{HG}$	-33.091	0.803			0.685	0.000	2.371
	$a \pm b_1 \text{HG} \pm b_2 \text{BL}$	-49.267	0.738	0.360		0.723	0.038	2.243
4	$a \pm b_1 \text{HG}$	-35.183	0.824			0.637	0.637	2.415
	$a \pm b_1 \text{HG} \pm b_2 \text{BL}$	-48.468	0.738	0.334		0.673	0.036	2.297
Overall	$a \pm b_1 \text{HG}$	-32.264	0.784			0.798	0.798	2.305
	$a \pm b_1 \text{HG} \pm b_2 \text{BL}$	-38.027	0.643	0.282		0.815	0.018	2.204

¹Dentition is same as in Table 1. *HG = Heart girth, PW = Pelvic width, BL = Body length, WH = Height at wither. ²Dependent Variable: Wt (Body weight).

Kassahun (2000) found out that heart girth alone explained 83% and 81% of weight of Menz and Horro ram lambs. The higher association of body weight with heart girth was possibly due to relatively larger contribution in body weight by heart girth (Thiruvankadan, 2005). The highest coefficient of determination ($R^2 = 0.82$) was obtained when the equations were fitted for the pool (for all dentition groups). Comparing for dentition groups, the highest coefficient of determination was depicted at age group 0 (75.9% of the variation in weight was explained by the equation). The differences in the coefficient of determination of equations between different dentition groups indicated that weight can be estimated using different equations for different age groups with different accuracies. Kassahun (2000) estimated different fitted models for different age groups. Within dentition groups, the coefficient of determination (it increases) revealed that weight was better predicted when two or more measurements were included in the equation.

Conclusion

The agricultural production system in the study area is mixed crop-livestock which complement each other in such a way that livestock are used as a source for draft and manure for crop production and from crop production the crop residues, straws and aftermath serve as main components of livestock feeds in the study areas.

Due to the increasing attention given to sheep production, because of the decreasing grazing land as a result of increasing population pressure, land slide and gully erosion and because of their suitability to produce and reproduce under feed shortage and the current increasing market value, production problems identified needs to be improved. The traditional management practices such as the weaning, docking and use of traditional herbal medications need to be encouraged and supported by scientific knowledge. The flock composition identified is within the range of many studies in Ethiopia. The higher proportion of old breeding ewes in the flock indicates that farmers in study area maintain breeding ewes for long period of time and the importance of culling.

The fixed effects of district, sex, dentition and the interaction between sex and dentition were sources of variation for the most of the response variables (linear body measurements). The high correlation coefficients observed between body weight and heart girth for all dentition groups suggest that heart girth alone or in combination with other body measurements could provide a good estimate of predicting live weight of Washera sheep at different dentition groups. The differences in the coefficient of determination of the equations fitted between different dentition groups indicated that weight can be estimated using different equations for different age groups with different accuracies. For ease of use and higher coefficient of determination, equations fitted for the pool (all age groups) or heart girth alone could be used in the field.

Acknowledgment

We are indebted to the Amhara Regional Agricultural Research Institute (ARARI) for fully financing the field research. We are also grateful to the International Livestock Research Institute (ILRI) for providing graduate fellowship to the first author while undertaking his MSc research thesis. The authors are greatly indebted to Mr Zerihun Taddese for his meticulous biometrics support during analyzing the data. We are grateful to the staff of Andassa Research Centre, particularly to Asresu Yitayew and Habtemariam Assefa for their support during the field work.

References

- Abebe Mekoya. 1999. Husbandry practice and productivity of sheep in Lalo-Mama Midir woreda of central Ethiopia. M.Sc Thesis. Alemaya University of Agriculture, Dire Dawa, Ethiopia. 91p.
- Aden Tekle. 2003. Evaluation of local sheep under traditional management around rural area of Dire Dawa. M.Sc Thesis. Alemaya University, Dire Dawa, Ethiopia. 128p.
- Afolayan, R.A., Adeyinka, I.A. and Lakpini, C.A.M.. 2006. The estimation of live weight from body measurements in Yankasa sheep. Czech J. Anim. Sci. 51(8): 343–348.

- CSA (Central Statistical Agency of Ethiopia). 2006. The 2006 National Statistics-Agriculture. http://www.csa.gov.et/text_files/2006_national_statistics.htm (accessed on Oct., 2007).
- Chipman, J. 2003. Observations on the potential of Dangila sheep for improved food security around Quarit and Adet, West Gojjam, northwestern Ethiopia. A Field Study Hosted by International Livestock Research Institute (ILRI), Addis Ababa, Ethiopia. 17 p.
- Ebangi, A.L., Nwakalor, L.N., Mbah, D.A and Abba, D. 1996. Factors affecting the birth weight and neonatal mortality of Massa and Fulbe sheep breeds in a hot and dry environment, Cameroon. *Revue d'Élevage et de Médecine Vétérinaire des Pays Tropicaux*. 49, 349–353.
- Field, A.P. 2005. *Discovering statistics using SPSS*. 2nd ed. Sage. London.
- Getahun Legesse. 2008. Productive and economic performance of Small ruminants in two production systems of the highlands of Ethiopia. PhD Dissertation, Stuttgart-Hohenheim. 160 p.
- Girma Abebe. 2008. Reproduction in sheep and goats. In: Alemu and Merkel (eds). *Sheep and Goat production hand book for Ethiopia*. Ethiopia sheep and goat productivity improvement program. Pp 57-77.
- Hamayun, K., Fida, M., Riaz, A., Rahimullah, G.N. and Muhammad, Z. 2006. Relationship of body weight with linear body measurements in goats. *J. Agric. and Biol. Sc.* 1 (3): 51-54.
- Ibrahim, H. 1998. *Small ruminant production technique*. ILRI manual 3. ILRI (International Livestock Research Institute), Nairobi, Kenya. 207 p.
- Kassahun Awgichew. 2000. Comparative performance evaluation of Horro and Menz sheep of Ethiopia under grazing and intensive feeding conditions. Ph.D Dissertation. Humboldt University, Berlin. 173 p.
- Mengistie Taye. 2008. On-Farm Performances of Washera Sheep at Yilmanadensa and Quarit Districts of the Amhara National Regional State. M. Sc. Thesis. Hawassa University, Hawassa. 133 p.
- Mukasa-Mugerwa, E., Lahlou-Kassi, A., Anindo, D., Rege, J.E.O., Tembely, S., Markos Tibbo, and Baker, R.L. 2000. Between and within breed variation in lamb survival

- and the risk factors associated with major causes of mortality in indigenous Horro and Menz sheep in Ethiopia. *Small Ruminant Res.* 37:1-12.
- SAS. 2003. SAS User's Guide: Statistics. Ver. 9.1. Cary, NC: Statistical Analysis System Inc.
- Sisay Lemma. 2002. Phenotypic classification and description of indigenous sheep type in the Amhara National Regional State of Ethiopia. MSc. Thesis. University of Natal, Pietermaritzburg. 104p.
- Solomon Abegaz. 2007. In-situ characterization of Gumuz sheep under farmers' management in north-western lowlands of Amhara region. MSc. Thesis, Haramaya University, Ethiopia. 108 p.
- Sowande, O.S. and Sobola, O.S. 2007. Body measurements of West African dwarf sheep as parameters for estimation of live weight. *Trop. Anim. Health Prod.* DOI 10.1007/s11250-007-9116-z.
- SPSS. 2003. Statistical Package for Social Sciences for Window. Version 12.0.
- Tesfaye Ashagre. 2008. Performance of Menz sheep under Traditional Management System in Dessie Zuria District of South Wollo, Amhara Region. MSc Thesis. Mekele University, Mekele. 169 p.
- Thiruvankadan, A.K. 2005. Determination of best-fitted regression model for estimation of body weight in Kanni Adu Kids under farmer's management system. *Livestock research for Rural development* 17(7). 11p.
- Tibbo, M., Ayalew, W., Awgichew, K., Ermias, E. and Rege, J.E.O. 2004. On-station characterization of indigenous Menz and Horro sheep breeds in the central highlands of Ethiopia. *FAO/UNEP Animal Genetic Resources Information.* 35, 61-74.
- Tibbo, M. 2006. Productivity and health of indigenous sheep breeds and crossbreds in the central Ethiopian highlands. PhD dissertation. Department of Animal Breeding and Genetics, Faculty for Veterinary Medicine and Animal Sciences, Swedish University of Agricultural Sciences (SLU), Uppsala, Sweden. 76p.
- Tsedeke Kocho. 2007. Production and Marketing Systems of Sheep and Goats in Alaba, Southern Ethiopia. Msc Thesis. University of Hawassa, Awassa. 172 p.

Current fish status of Koga River and dam in West Gojjam, Ethiopia

Miheret Endalew

Email: miheretendalew@yahoo.com

Amhara Region Agricultural Research Institute, Bahir Dar Fish & Other Aquatic Life Research Center

Abstract

The pre-feasibility and feasibility study for the development of Koga River dam located in West Gojjam zone of Amhara region in Ethiopia lack adequate fishery information. The objectives of the current study were to assess the current fish status of Koga River, characterize the fishery, assess the impact of the reservoir constructed upstream of the River, create awareness and propose measures to develop and sustain the fishery. Assessment of the fishery was carried out for eight sampling periods (three samplings in 2006, four samplings in 2007 and one sampling in 2008) at four sampling sites starting from the confluence of Koga and Gilgel Abay Rivers upstream to the Koga reservoir. Characterization of the fishery included identification of fish species, composition, size, and abundance during the dry and the wet seasons using gillnets of different mesh size for fish sampling. Ten species belonging to three genera and two families were identified from the four sampling sites. The highest species diversity was recorded from Gilgel Abay and Koga confluence (ten species) followed by Abay Gulit (six species) and the fish diversity decreased upstream towards the reservoir with two species being identified in each of Dengia ber and Koga dam, respectively. This decline in fish diversity could be due to natural factors and upstream damming. Assessment of the river flow showed that the base flow immediately below the reservoir is highly reduced which could negatively affect the biodiversity, particularly the fish diversity. Furthermore, the local community's subsistence fishing activity is not regulated. The unregulated open access resource use and uncoordinated water resources development activities will cause degradation of fish resources in particular and other natural resources in general. It is highly important that stakeholders involved in the development of Koga reservoir and other reservoirs in the future should consider the development, management and utilization of Koga River and reservoir fishery and other living resources for posterity.

Key words: Diversity, fishery, Koga dam, Koga River, migration

Introduction

Natural water bodies such as rivers and lakes are primarily the natural habitats for fish and other aquatic life forms. Such water bodies also have other uses for mankind, among which harnessing these resources for irrigated crop production is the major activity in Ethiopia

currently. Harmonizing the various uses of these water resources is essential for their sustained utilization.

The Koga watershed (Figure 1) falls in Woina Dega and Dega climatic zones, the majority being Woina Dega with distinct dry (November to April) and wet season ((May to October). The major river in the watershed is Koga River which is located in Mecha Woreda, West Gojjam Zone in Amhara National Regional State. Koga River is one of the tributaries of Gilgel Abay which flows into Lake Tana and used as spawning ground for the migrating *Labeobarbus* fish species. The upstream part of Koga River is under construction for dam that conserves the rainy season Koga river discharge for later irrigation in the dry season. The dam is 21.5 m high and 1860 m long with a storage capacity of 77 Mm³. The dam was well designed with spillway for discharge of 336 m³ sec⁻¹ at a reservoir level of 2016.8 m, provision of low-level outlet to release the dry season compensation flow rate at 1 m³ sec⁻¹ to the Koga River, and irrigation off take of 9.1 m³/s, bottom outlet of 31 m sec⁻¹. However, there is no designed structure of any fish path for upstream and downstream movement of fish.

Considering the effect of the dam construction on fish and other aquatic life, the Bahir Dar Fishery & Other Aquatic Life Research Center planned to conduct assessment of the current fish status at Koga River and the reservoir. The objectives of the assessment were to identify the fish species, composition, size, abundance; characterize the fishery and assess impacts of the reservoir construction upstream and create awareness among the different stakeholders to sustain and enhance the fishery resources in the Koga River basin.

Materials and methods

The study area

Koga River is located at N 11.58913° and E 37.37975° in Mecha woreda West Gojjam Zone of the Amhara National Regional State. From its source in the hills north of the Wezem Mountains, Koga river flows a distance of some 49 km to join Gilgel Abay which flows into Lake Tana. Gilgel Abay is considered as spawning ground for the migrating

Labeobarbus fish species. A reservoir is constructed in the upstream part of the river. The fish status assessment was carried out at the confluence of Koga and Gilgel Abay Rivers (N 11.37 54, E 37.03 21), Abay Gulite (N 11.21 28, E 37. 04 32), Dengia ber below the dam, with pools and rifles having >2 meters depth and confluence of Koga and Burka Rivers (N 11. 20 31, E 37. 08 39) at the dam site.

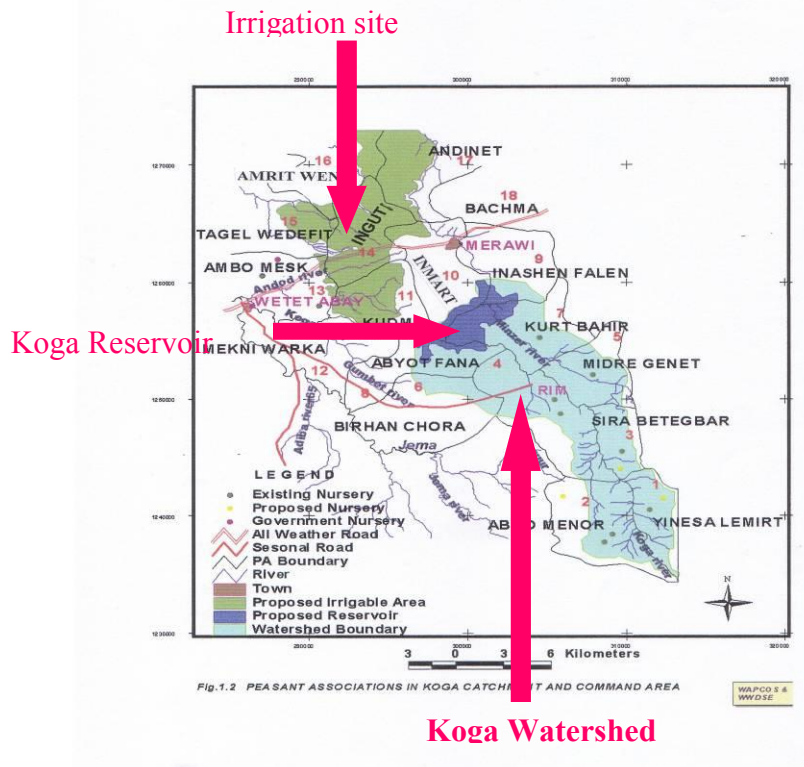

Figure 1. Koga watershed site map

Data collection and analysis

Gillnets (6, 8, 10 & 12 cm stretched mesh size) with 25 m length and 2 m width were used and set for 12 hours during the night and lifted in the morning. All of the fishes caught were identified to species level with immediate inspection with the help of identification key. Measurements of Fork length and total weight were taken using measuring board and sensitive balances. Each fish was sexed and dissected and the gonad maturity stage was determined and recorded.

Environmental parameters were also recorded using GPS, oxygen meter, pH meter and conductivity. Water transparency was measured with Secchi Disk and measuring rope. Survey of fishery activity on the river was conducted through interviewing the livestock and extension experts from the Mecha Woreda Office of Agriculture.

Results and discussion

Fish species diversity

A total of 674 fish sample consisting of 293 male, 371 female and 10 with unidentified sex was collected. Ten species belonging to three genera and two families were identified from the four sampling sites (Table 1). Among the identified ten species, eight species belonged to the genus *Labeobarbus* and the remaining two species belong to genera *Varicorhinus* and *Clarias*. *Labeobarbus* was the most abundant genus. However, when abundance is considered in terms of the size of the fish population (deduced from the number of fish sampled), the genus is less abundant compared to the non-*Labeobarbus* genera. The *Labeobarbus* genus, with 270 fish sampled, accounted for only 40% of the total fish sampled.

Table 1. Species of fish identified from Koga River and dam.

Family	Genus	Species
Cyprinidae	<i>Labeobarbus</i>	<i>acutirostris</i>
Cyprinidae	<i>Varicorhinus</i>	<i>besso</i>
Cyprinidae	<i>Labeobarbus</i>	<i>brevicephalus</i>
Clariidae	<i>Clarias</i>	<i>garipienus</i>
Cyprinidae	<i>Labeobarbus</i>	<i>crassibarbis</i>
Cyprinidae	<i>Labeobarbus</i>	<i>gorguarir</i>
Cyprinidae	<i>Labeobarbus</i>	<i>intermedius</i>
Cyprinidae	<i>Labeobarbus</i>	<i>megastoma</i>
Cyprinidae	<i>Labeobarbus</i>	<i>nedgia</i>
Cyprinidae	<i>Labeobarbus</i>	<i>tsanensis</i>

Spatial distribution of fish species

The spatial distribution of fish species is presented in Table 2. The number of fish species identified in the four sampling sites (Gilgel Abay and Koga confluence, Abay Gulit, Dengia ber and Koga dam) ranged from two to ten. A higher number of species was found in Gilgel Abay and Koga confluence and Abay Gulit. Dengia ber and Koga dam sites had very low species diversity.

Table 2. Spatial distribution of fish species at the four sampling sites.

Species	G. Abay & Koga			
	Confluence	Abay Gulit	Dengia Ber	Koga Dam
<i>Labeobarbus acutirostris</i>	✓			
<i>Varicorhinus beso</i>	✓	✓	✓	✓
<i>Labeobarbus brevicephalus</i>	✓			
<i>Clarias garipienus</i>	✓	✓	✓	✓
<i>Labeobarbus crassibarbis</i>	✓	✓		
<i>Labeobarbus gorguarir</i>	✓			
<i>Labeobarbus intermedius</i>	✓	✓		
<i>Labeobarbus megastoma</i>	✓			
<i>Labeobarbus nedgia</i>	✓	✓		
<i>Labeobarbus tsanensis</i>	✓	✓		

This assessment work indicated that fish diversity increases towards Gilgel Abay River which is considered as spawning ground for *Labeobarbus* species. It seems reasonable to find higher diversity in sites that are closer to the spawning ground of Gilgel Abay. However, it should be emphasized that the level of diversity could depend on the magnitude of sampling, the gear type applied in sampling and the time of sampling.

Spatial distribution of the fish population

Table 3 shows distribution of the fish population in Koga River and dam across the four sampling sites. Considering the number of fish captured in the four sites, Gilgel Abay and Koga confluence, Abay Gulit, Dengia ber and Koga dam, respectively accounted for 41.5%, 15%, 5% and 37.7% of the total fish population. The species and the fish population spatial distribution show that these two parameters may not necessarily correlate positively.

This is exemplified by Koga dam sampling site where the fish population size is considerably high despite the low species diversity in the site.

Table 3. Spatial distribution of fish population at the four sampling sites.

Sampling sites	Number of species	Number of fish sampled	Percentage of total fish sampled
G. Abay & Koga confluence	10	279	41.45
Abay Gulit	6	106	15
Dengia ber	2	35	5
Koga dam	2	254	37.74

Overall species abundance

The most abundant species were *Clarias gariepinus*, *Labeobarbus intermedius*, *Varicorhinus beso* and *Labeobarbus nedgia* in order of abundance (Table 4). The most abundant *Labeobarbus* species were *Labeobarbus intermedius*, *Labeobarbus nedgia*, *Labeobarbus crassibarbis* and *Labeobarbus brevisephalus* in order of abundance. *Clarias gariepinus* and *Varicorhinus beso* species were caught together with the *Labeobarbus* species. *Clarias gariepinus* and *V. beso* were common across all sampling sites.

The *Labeobarbus* species number increases downstream for the reason that *Labeobarbus* species migrate towards Gilgel Abay River. *Labeobarbus Intermedius* and *Labeobarbus nedgia* species collected in the Koga River are most probably dwelling in the river. This riverine dwelling behavior of this species was also reported from Megech River basin (Wassie Anteneh, 2005; Abebe Getahun *et al.*, 2008) in Ribb River but this requires further research and verification. The current fishery resource status in the Koga River is not well studied and the inadequacy of the information on the fish resources has been stated in the pre-feasibility and feasibility study of Koga dam.

The highest proportion of *Clarias gariepinus* sample (223 fish) was collected from the upper most sampling site, i.e. the reservoir/dam. This is because of the dam's proximity to two important sources of *Clarias gariepinus*. The dam completely encloses Burka River and is connected with Kurt Bahir through Gibit River although it is far from the reservoir.

As expressed by the local people, peak *C. gariepinus* migration occurs at the beginning of July where the Kurt Bahir and Koga flood plain are connected through the Gibit River. This movement may be related to spawning period for *C. gariepinus*. The *Labeobarbus* species was not found in the upper two sampling sites namely Dengia Ber immediately below damming site and Koga dam.

Table 4. Total abundance of fish species in Koga River and Koga dam.

Species	Number of fish sampled
<i>Labeobarbus acutirostris</i>	1
<i>Varicorhinus beso</i>	99
<i>Labeobarbus brevicephalus</i>	12
<i>Clarias gariepinus</i>	305
<i>Labeobarbus crassibarbis</i>	13
<i>Labeobarbus gorguarir</i>	4
<i>Labeobarbus intermedius</i>	189
<i>Labeobarbus megastoma</i>	1
<i>Labeobarbus nedgia</i>	45
<i>Labeobarbus tsanensis</i>	3

Community fishing activity

The fish resource in Koga River has been utilized by the local community at subsistence level of production and without adequate information on the fish resource and regulatory mechanism. According to the community, the fishing activity is relatively higher during the wet season which could result in more *Labeobarbus* fish migration in the future. Presently the most frequently used fishing gears in Koga River and other nearby rivers and tributaries in the local communities are gill nets, scoop nets, traps, and hooks that are not controlled and managed. Illegally poisoning with *Birbira* (*Milletia ferruginia*) is also used during the dry season when the river water flow level is at its lowest and poisoning with *Birbira* during the dry season plays a very significant role in devastation of the fish indiscriminately in the river course. Scoop nets are mainly used during the rainy season because gillnets are difficult to set at flooding period where the river is at its maximum

water level and with strong velocity. Traps, hooks, and scoop nets contribute little to the total catch in the local community fishing activities.

The gill nets used in the local communities are either nylon monofilament gillnets (7 to 9 cm stretched mesh size, 20 to 30 m long) made locally by the fishers themselves and called traditional nets. Multi-filament nets (10 to 12 cm stretched mesh sizes, 50 m long) called modern nets are sometimes purchased at Bahir Dar (personal Communication). The traditional fishers use the above stated fishing gears in the Koga River mostly during the end of the wet season where flooding is minimized. The engagement of the local community in fishing on the river contributes to ensuring food security, supply of cheap source of protein, job creation for the local community.

Effects of reservoir construction on fish diversity

A river system plays a vital role in the life cycle of migratory species of fish. It is a route up or downstream that spawners reach their spawning grounds, and fish in their young stage of life reach their feeding, shelter and refugee grounds. For such species an obstruction like Koga reservoir can spell their fate. Koga reservoir not only prevents migration upstream, but also affects fish migrating downstream. Fish migrating downstream can be led into irrigation ditches, stranded and die. Such situation may not be avoided due to lack of fish passage structure and screening mechanism in Koga dam construction design. The diversity decreased upstream towards the Koga reservoir. This decline could be due to natural environmental effects or upstream damming effects. The environmental parameters (Table 5) did not show significant difference among the sampling sites which could rule out the effect of environmental factors on the observed variation in fish diversity across locations. On the other hand, the base flow has been highly reduced from the reservoir downstream to Dengia Ber sampling site without considering the requirements for survival of the fish genetic resource.

Dam building generally has a major impact on fish and biodiversity. The major effects include upstream and downstream migrations and inaccessibility to suitable habitats. Factors that contribute to the effects include changes in water discharge, possible fish

damage in irrigation canals and by hydraulic turbines, over spillways and increased upstream and downstream predation resulting from fish being restrained by the dam and the habitat becoming more favorable to certain predatory species including fishers. The negative effects of these obstructions which prevent migration between feeding and breeding zones have been much more significant than water pollution, over fishing and habitat destruction in the main rivers.

Table 5. Physico-chemical characteristics of the four sampling sites.

Sampling site	Temperature	Oxygen mg/l	pH	Conductivity
G. Abay and Koga confluence	18.73	6.73	7.63	109.74
Abay Gulit	18.7	6.2	7.8	140.53
Dengia Ber	20.1	6.87	7.8	166.5
Koga Dam	20.14	6.95	7.63	190.7

Conclusion and Recommendation

According to the current study, ten species belonging to three genera and two families were identified in the Koga River system. *Labeobarbus* is the most abundant genus, but the most abundant species is *Clarias gariepinus*. The study also confirms that the negative effects of reservoir construction on fish diversity as Koga dam has very low species diversity compared to the other sampling sites. However, the fish population in Koga dam is considerably high. Unregulated fishing activity by the local community also affects the fish species diversity.

Results of the present study provide information towards mitigating the negative effects of water resource development on aquatic life resources in Koga river system. Despite the large aquatic resources in the region, the research and development efforts for conservation, development and management of these resources so far can be considered inadequate and uncoordinated. As a result there is virtually inadequate scientific information on the aquatic ecosystem and wetland resource base used by different stakeholders for different purposes.

The aquatic ecosystem and wetland use policy has not yet been implemented effectively. If captured fishery and aquaculture should contribute to food security and poverty reduction, the aquatic ecosystems that support these resources need to be managed and maintained.

Acknowledgements

I am thankful to the Bahir Dar Fisheries and Other Living Aquatic Resources Research Center, the Amhara Regional Agricultural Research Institute, Amhara Region BoWRD, West Gojjam Zone Administration, Mecha Woreda oARD. I also thank Belay Abdissa, Goraw Goshu, Wondie Zelalem, Beniam Hailu, Birhan Mohamed, Temesgen Minaye, Ayenew Gediff, Tiruneh Atanaw, Asnake Aynekulu, Habtamu Muche and Habtamu Degu for their assistance in doing the research. I am very thankful to Ato Mulat Workineh at Abay and Koga confluence, Qeise Degu Worku at Abay Gulit, and Ato Bekel Meles and Ato Genanew for their fishing service and guarding our nets during the night setting.

References

- Abebe Getahun, Eshete Dejen and Wassie Anteneh. 2008. Fishery Studies of Ribb River, Lake Tana Basin, Ethiopia. Final Report Vol. 2, Presented to the World Bank-financed Ethiopian-Nile Irrigation and Drainage Project Coordination Office, Ministry of Water Resources.
- Wassie Anteneh. 2005. Spawning migration and Reproductive biology of labeobarbus (cyprinidae: teleostei) of Lake Tana to Dirma and Megech Rivers, Ethiopia. M.Sc.Thesis, School of Graduate Studies, Addis Ababa University.

Goat marketing in northern highlands of Ethiopia: The case of *Wag-Hämera- Mekelle* supply shed

Leulseged Kasa

Email: leulseged1979@gmail.com

Sekota Dry land Agricultural Research Centre, Amhara Regional Agricultural Research Institute

Abstract

A rapid assessment of goat marketing was conducted in 2009 in Wag-Hämera-Mekelle supply shed, Ethiopia. The survey was aimed at generating information on the characteristics, constraints, and opportunities of goat marketing. Amdework, Kedamit, and Nyere Aqu (primary), Sekota (secondary) and Mekelle (terminal) markets were studied. Findings revealed that suppliers were smallholder farmers and the gross and net off-take rates during 2008 were estimated at 23.7% and 12.9%, respectively. The prevailing marketing system is characterized by involvement of large number of illegal farmer traders across the market chains with traditional marketing way of conduct. The dominant market outlet was found to be towards Mekelle. Taking producer prices at Sekota and retail prices at Mekelle, producers' share of the retail price for castrated, uncastrated, and adult female goats were estimated to range from 23 to 50%, 28 to 36%, and 23 to 50%, respectively. The corresponding gross profit ranges were 135-185, 25-35, and 75-120 ETB head⁻¹, respectively. Absence of coping strategies against the frequent drought, underdeveloped market infrastructures, and involvement of many informal actors were the major marketing constraints. Hence, appropriate research and development interventions must be undertaken to have continuous and quality product in the required amount for the growing domestic and international livestock markets.

Key words: Goat, marketing, Wag-Hämera.

Introduction

In Wag-Hämera, given their relative low input requirement, goat production has been felt as more rewarding enterprise under the prevailing ecological niches (Adefris *et al.*, 2000; Ephrem *et al.*, 2006). As a result, currently more than 60% of farm households in the area have been engaged in goat raising parallel to other farm activities (CSA, 2008).

Even though there have been considerable number of goat population in the nationality administration, its economic contribution to smallholder producers is very low. This is

attributed to, among many other things, the poor marketing system prevailing in the area. In a condition where there are very few and poor marketing services, research in agricultural marketing is of paramount importance. It can contribute in the establishment of facts and description of the existing marketing systems that may be necessary for developing appropriate marketing policies and strategies (Adefris *et al.*, 2000).

An efficient marketing system stimulates increased farm production and leads to proportionate increases in the level of real income of the farmers. Hence, to promote efficient goat marketing system in the area, the existing marketing characteristics should be well understood, potentials and constraints should be identified. Therefore, this survey was conducted to characterize live goat marketing system of the area, identify major marketing constraints, and explore opportunities for goat marketing.

Methodology

The study area

The study was conducted in Wag-Hämera nationality administration of ANRS, where more than 93% of the population lives in rural areas (PCC, 2008). The farming system of the area can be characterized by crop-livestock mixed farming, and agro pastoral in some parts of Tekez, Tirari, and Tella river basins. Currently, the total goat population found in the area was estimated at 560 528 (CSA, 2008). Abergelle and Central highland goats are the dominant breeds reared in the area (Belay, 2006; Mohamed *et al.*, 2007). The goat production system of the area can best be described as free grazing and browsing under traditional management practice (Adefris *et al.*, 2000; Ephrem *et al.*, 2006).

Data collection and analysis

In this survey, commodity approach was adopted to assess live goat marketing system. This approach helps to examine the entire marketing chain of a single product in an integrated manner (Drummond and Goodwin, 2001). A rapid market appraisal technique was employed for gathering the required data and information. Accordingly, primary information on the overall marketing characteristics, consumer preferences, marketing

constraints, and opportunities were collected from primary and supportive marketing actors in the primary (Dehana, Kedamit, and Nyere Aqu) and secondary (Sekota) markets, and in the terminal market (Mekelle). In addition, secondary data were also taken from the institutions contacted and CSA reports.

The gross and net off-take rate estimation methods used by Asfaw Negassa and Mohammad Jabbar (2007) were employed.

$$\text{Gross commercial offtake rate} = \left(\frac{\text{Sales}}{0.5(\text{Opening Stock} + \text{Ending Stock})} \right) * 100$$

$$\text{Market off - take rate} = \left(\frac{\text{Sales} - \text{Purchases}}{0.5(\text{Opening Stock} + \text{Ending Stock})} \right) * 100$$

Results and discussion

Off-take rates

The gross and net commercial off-take rates of the area were computed based on data obtained from the 2008/09 agricultural sample survey of CSA (2008). Accordingly, the gross and net off-take rates were 23.7% and 12.9%, respectively (Table 1). These figures were lower than the national and regional figures, which were 26.5% and 32.3% for gross off-take rates and 15.9% and 15.7% for net off-take rates, respectively.

Table 1. Gross and net off-take rates of goat in Wag-Hämera nationality administration, 2008.

Geographic area	Opening Stock	Ending Stock	Average Stock	Sales	Purchase	Gross	Net
						Commercial off-take rate	Commercial off-take rate
Ethiopia	10,765,609	21,884,222	16324916	4,328,136	1,729,980	26.51246	15.91528
ANRS	2,452,193	6,022,105	4237149	1,371,051	705,244	32.35787	15.71356
Wag-Hämera	300,325	560,528	430426.5	102,172	46,558	23.73739	12.92067

Goat marketing structure

The structure of goat marketing in the area can be characterized by dominance of primary markets (Sekota was the sole secondary market), which were not distributed fairly in all weredas of the nationality administration, and nearly 47% were inaccessible for vehicles (Table 2).

Table 2. Market centers in Wag-Hämera nationality administration, 2008.

		<i>Woredas</i>					
		<i>Abergelle</i>	<i>Sehala</i>	<i>Ziqualla</i>	<i>Dehana</i>	<i>Gazgibla</i>	<i>Sekota</i>
		Nyere Aqu ^{AWR*}	-	Tsitsika ^{AWR}	Amdework ^{AWR}	Taba ^{AWR}	<i>Sekota</i> ^{AWR}
		Dihirgiba ^{NA}	-	Kedamit ^{DWR}	Chilla ^{AWR}	<i>Asketema</i> ^{AWR}	Hamusit ^{AWR}
				Mishira ^{NA}	Koziba ^{AWR}	Iksa ^{NA}	Dable ^{AWR}
				Kamariam ^{NA}	Azilla ^{NA}	Nobogela ^{NA}	Tsemera ^{AWR}
				Telaje	Silda Hamusit	Sella ^{NA}	Siriel ^{AWR}
Market				Hamusit ^{DWR}	NA		
Site					Arbit ^{NA}	Hamusit ^{NA}	Jerba ^{DWR}
							Itsa ^{NA}
							Bad
							Georgis ^{NA}
							Tsata ^{DWR}
							Mukun ^{NA}

^{AWR} = all weather road, ^{DWR} = dry weather road, ^{NA} = not accessible for vehicles.

Source: From administrative map of Wag-Hämera developed by COOPI, 2007.

All, except Sekota market, were open markets. There were about six outlets, which link these primary and secondary markets to other neighboring zones in the Amhara and Tigray regions. However, the Mekelle root was the dominant one and the shares of others were minimal and seasonal (Figure 1).

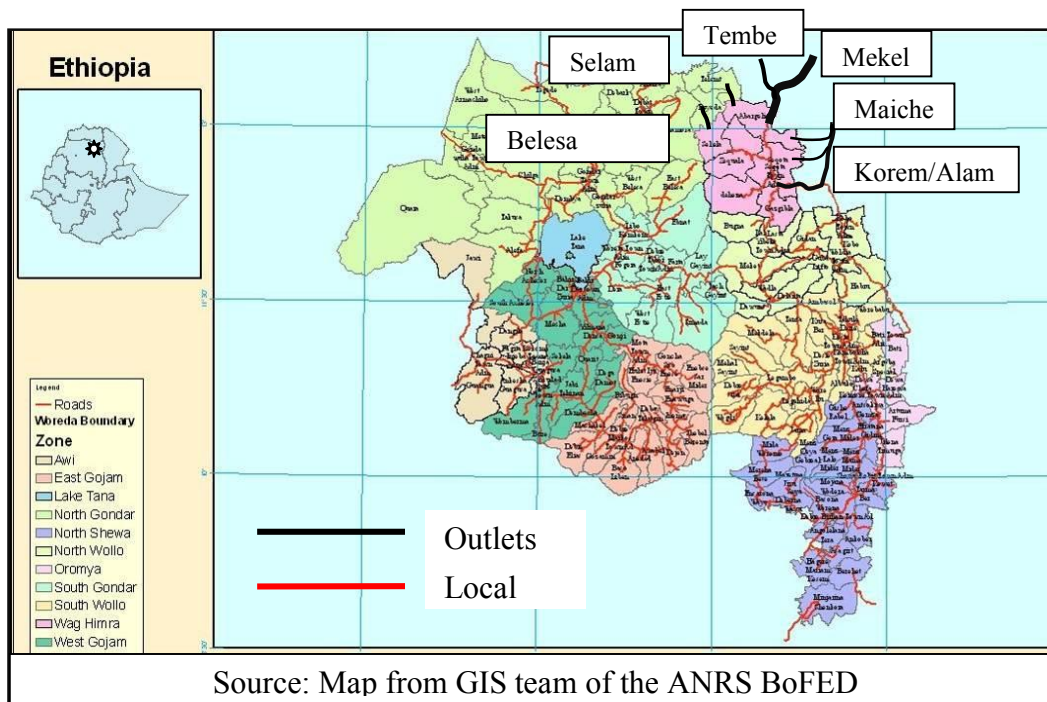

Figure 1. Goat marketing roots in Wag-Hämera nationality administration.

The chain/level of goat marketing in the area was very short/direct (Figure 2). The main marketing actors were local collectors, wholesalers, and retailers. Most local collectors were farmers, who perform as part time. They have place and time value addition functions. In the other ways, wholesalers, mostly come from Tigray, purchase either directly from producers in retail bases or from local collectors as a block (in Amharic ‘*Jamla*’). However, most wholesalers visit only those market centers, which have road and transport access, and found along main roads. These have place and time value additions too. Within the nationality administration level, retailers have dual function, collection and retailing. However, in *Mekelle* there were retailers who primarily engaged on retailing activities. Some of them had their own or rented in holding centers and use supplemental feeding.

Goat marketing conduct

Regarding the market *conduct* of the area, major actors of goat marketing need to have either registration or licenses. Traders coming from outside the nationality administration,

whether they have licenses from their origin or not, must have short-term registrations by micro and small-scale trade and industry promotion office in the respective woredas. They will only be charged ETB 10 as registration fee. Actors within the geographic territory must also be registered if their capital is less than ETB 3000, or need to have licenses if their capital is greater than ETB 3000. However, the number of legally registered traders in both cases was few when compared with illegal actors. There were about 21 formally registered and licensed traders for livestock retail in Sekota town, as of June 2009. Out of whom 10 were from Tigray region and registered, 8 were from Sekota town and registered, and the remaining 3 were also from *Sekota* town and only licensed. However, the number of illegal traders was believed to exceed than legal traders.

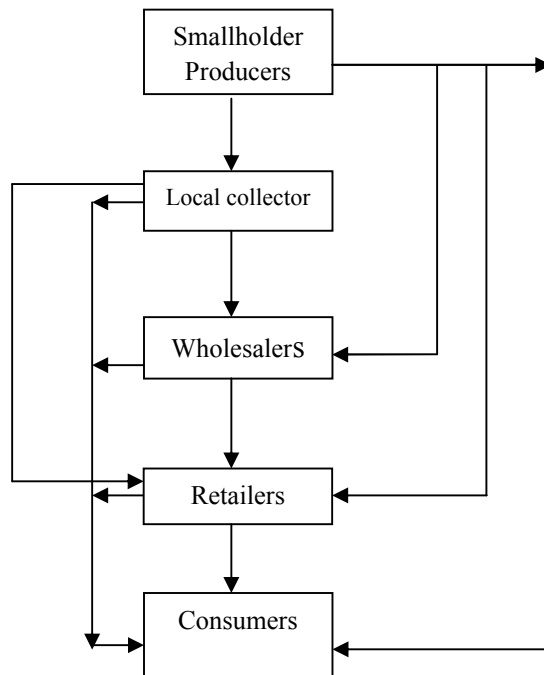

Figure 2. Goat marketing channels in Wag-Hämera

The other feature of goat marketing actors was their multiple functions. There was no clear distinction of work among actors, collectors from wholesalers, wholesalers from retailers, and local collectors from retailers. In addition, they involve in other livestock marketing too. In relation to supportive marketing facilities, traders use traditional market information

system, operate in the absence of grading and standardizing systems, and both trekking and trucking transportation mechanisms were used.

Goat marketing performance

Concerning the performance of live goat marketing of the area consumer preferences, price analysis, and gross margins were considered. Accordingly, given their better fat content, meat softness, better shelf life, and weight, highland goat breads were preferred for home consumption. In the other ways, due to poor fat content, hard meat, short shelf life, lesser weight of Abergelle breads, only institutional consumers were preferred them. These breads are also preferred for export markets. During transactions, buyers consider their purpose of purchase, bread, sex, age, season, body condition, and place of purchase to set prices and pass purchase decisions.

Depending on their interest, prices are set based on negotiations between the seller and buyer. As indicated in Figure 3 prices vary across seasons of the year for different age and sex classes. For instance, during fasting season, like February to March all goat prices tends to lower and for Easter season, it raises. From June to July the price of adult female goat and yearling kids was raising due to less supply due to other farm activities and high purchase demand for fattening by Save the Children (Non Governmental organization Working in the Area). However, the price of castrated male goat was declining due to the supply of poor body conditioned and less demanders. The demand for castrated goats is mostly for Christmases and Easters. As a result, there may not be supply of it in some seasons. The price of uncastrated goat was somehow constant throughout due to its stable demand for institutional consumers and constant supply.

Taking the prices of castrated goat, uncastrated goat, and adult female goat at Sekota and Mekelle, producers' share of the retail price ranges from 23-50%, 28-36%, and 23-50%, respectively, the balance percentages retained by retailers (Table 3). The major marketing costs in the area per head were cost of trekking (ETB 2 from Koziba to Sekota), trucking (for those who use ISUZU, from Sekota to Mekelle ETB 6-10), service charge (ETB 1 at Sekota), and transfer tax (ETB 1 at Koziba and Nyere Aqu/Abergelle), supplemental feed at

Mekelle (ETB 2.5 Kg⁻¹), and rent for holding centers at Mekelle (ETB 0.25 per day). Overall, the total marketing costs from Sekota to Mekelle were estimated to be ETB ≤15 per head. Considering this, the gross profit per head for castrated, uncastrated, and adult female goats ranges from ETB 135-185, 25-35, and 75-120, respectively (Table 3).

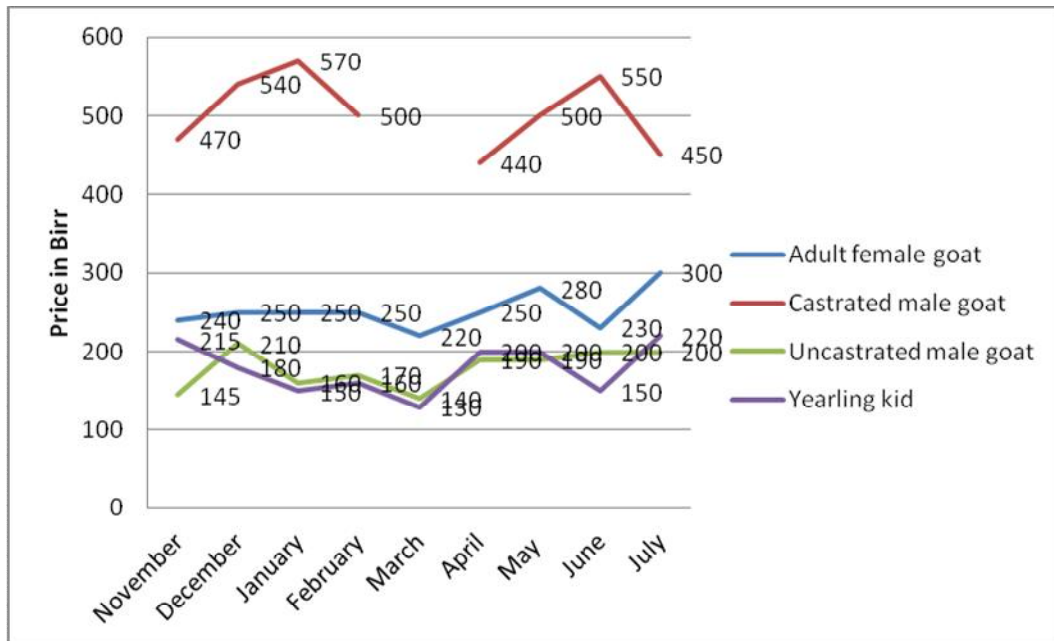

Figure 3. Nominal goat price trends in Sekota market 2008/09 (Source: data from Marketing process of Sekota WARDO).

Table 3. Farmers' share of retail price and gross profit (September-May 2009).

Characteristics	Farmers' selling											
	price at Sekota in ETB			Retail price at Mekelle in ETB			Gross/Marketing Margin/%			Gross profit/ETB		
	Exp	Cheap	Normal	Exp	Cheap	Normal	Exp	Cheap	Normal	Exp	Cheap	Normal
Castrated	650	400	450	800	600	650	0.23	0.50	0.44	135	185	185
Uncastrated	180	125	140	230	170	180	0.28	0.36	0.28	35	30	25
Adult female	300	200	230	370	300	320	0.23	0.50	0.39	120	85	75

Marketing constraints

- Supply of poor body condition goats to markets – given the prevailing recurrent drought in the area, shortage of feed and water have been occurring in many years. In addition, disease outbreaks in these seasons contribute to poor body condition for the remaining animals from death. For these problems, when we compare the goat population of the area, either farmers or supportive organizations have no strategically devised development and/or other drought coping mechanisms, which can reduce drought hazards. As a result, goats supplied to markets were poor in their body condition. According to wholesalers' explanation, this problem was particularly important in dry seasons.
- Absence of market centres and road access in some goat potential area - as stated before market centres in all woredas of the nationality administration were not distributed evenly. The existing market centres were concentrated along the main roads of Sekota, Gazgibla, and Dehana woredas. Apart these about 47% of the market centres in the nationality administration were not accessible for vehicles and most potential kebeles in these and other woredas do not have nearby market centres at all.
- Seasonality in supply – the prevailing goat supply was seasonal and this may be considered as a constraint to exporters, which can be the potential buyer to the area. These exporters require sustainable supply of exportable commodities to the international markets.
- Involvement of informal actors – though not actual estimates have been made, the number of informal actors were believed to exceed than formal marketing actors. This is because most traders in local markets were farmers who involves in par time terms and act seasonally. As a result, they do not believe that the income earned from this activity will cover their livelihoods and they do not tend to be legally registered.
- Absence of well-developed market information system - In some woreda town market centres, market information has been collected by different organization though not in a continuous way. The efforts to disseminate this information were not as to data collections. The information in general either not communicated to end users or the communication Medias were backwards. Even they were not interlinked with regional,

national, and international information. As a result, sellers and buyers use their traditional information communication means.

- Small-scale production – producers are smallholders. No organized producers groups or cooperatives exist to promote large-scale production to enjoy economies of scale.

Market opportunities

From infrastructure point of view, the geographical location of the nationality administration by itself has location advantage for the newly established slaughtering houses at Mekelle, and Kombolcha. Even it can potentially benefit from Bahir Dar and Gondar Slaughtering houses too. Further, there are Mekelle and Lalibela airports within 175 and 130 km radius, respectively for exports. In addition, from demand side, there has been increasing consumption of goat meat and as a result a growing demand for goat meat from Ethiopia (Desta *et al.*, date not specified). The other basic opportunity is the possibility of developing goat production at large scale/commercial goat production. For this, the large goat population, vast grazing land for rangeland development, and many perennial rivers would help a lot. The other opportunity is the sector has been identified as development priority area for intervention.

Conclusion and Recommendations

Supply of quality goat in sufficient quantity has not yet attained when considered with its potential. Even the gross and net off take rates were lower than national and regional figures. The marketing system for live goat is very traditional and not interlinked with alternative potential domestic and international markets. Given limited access of producers to markets, they are getting lowest share of retail prices. In the other ways, intermediate marketing actors are enjoying rewarding gross profits. To have efficient and effective marketing system in the area the following points need to be considered.

- Undertake a regular review of terminal markets in domestic and international markets to benchmark market prices in local markets (primary and secondary markets).

- Develop Market Information System and networking - The respective marketing promotion offices should establish strong marketing information system and work with other similar organizations like Abergelle International Livestock Development and regional and national media.
- Improve the capacity of producers—organizing producers in to goat marketing cooperatives will help producer to strengthen their negotiation power, have better information access, and get access to credit facilities.
- The extension system must be strategically geared towards bringing market oriented production system. For that supportive organizations should revise their structure and human resource.

References

- Adefris TekleWold, Agajie Tesfaye, Aster Yohannes, Birhane Kidane, Dereje Gorfu, Elias Zerfu, Mengistu Alemayehu, and Worku Atlabachew. 2000. Participatory farming systems characterization and intervention options for Sekota woreda, Wag himra zone (amhara region). Holetta Agricultural Research Centre, EARO.
- Asfaw Negassa and Mohammad Jabbar. 2007. Livestock ownership, commercial determinants in Ethiopia. ILRI. Nairobi, Kenya.
- Belay Deribe. 2008. Growth, Reproductive Performance and Carcass Characteristics of Abergelle and Central Highland Goat Types under Traditional and Slightly Improved Management in Sekota Woreda. MSc. Thesis, Haramaya University.73p.
- CSA (Central Statistical Agency). 2008. Agricultural Sample Survey 2008/2009 [2001 E.C]. Volume II. Report on Livestock and Livestock Characteristics (Private Holdings). Statistical Bulletin No. 446. FDRE: Addis Ababa, Ethiopia.
- Drummond, H. E. and Goodwin, J.W. 2001. Agricultural Economics. Prentice Hall, Inc., New Jersey.
- Ephrem Fufa, Belay Deribe, Haile Adamu, and Temesgen Alene. 2006. Characterization and Analysis of the Farming Systems of Dahina Woreda, Wag-Himra zone.

- Ephrem Fufa, Belay Deribe, Haile Adamu, and Temesgen Alene. 2005. Characterization and analysis of the farming system of Ziqualla Woreda, Wag Himra zone.
- FAO (Food and Agricultural Organization of the United Nation). 2004. Livestock Sector Brief: Ethiopia.
- Mohamed Jabbar, Asfaw Negassa and Taye Gidyalew. 2007. Geographic distribution of cattle and shoat populations and their market supply sheds in Ethiopia. Discussion paper No. 2. Improving Market Opportunities. ILRI (International Livestock Research Institute), Nairobi, Kenya. 54pp
- PCC (Population Census Commission). 2008. Summary and Statistical Report of the 2007 Population and Housing Census. Population Size by Age and Sex. December 2008. FDRE: Addis Ababa, Ethiopia.

On-farm verification of improved feeding systems for highland sheep in North Shewa zone of Amhara region

Nake Ziku, Beneberu Teferra, Aschalew Tsegahun, Tesfaye Getachew, Ayele Abebe
Debre Birhan Agricultural Research Center, P.O.Box 112, Debre Birhan, Ethiopia

Abstract

The study was conducted on-farm at Syadebrena Wayu district from end of January to mid April 2008 to verify alternative dry season sheep supplementation under farmers' management. Sixty highland yearling ram lambs were used in the study. Animals were grouped into four feeding treatments: T₁ (grazing alone), T₂ (grazing + 500 g mixed concentrate (30.75% noug cake (*Guizotia abyssinica*), 50% wheat bran, 18% oat grain, 1% limestone, and 0.25% salt)), T₃ (grazing + 150 g oat grain + 150 g noug cake), and T₄ (grazing + teff straw adlib + 300 g noug cake + multi-nutrient block adlib). All the supplemented groups (T₂, T₃ and T₄) gained significantly more weight than the control (T₁). Among the supplemented groups, sheep in T₂ attained the highest final weight (23.88±0.23 kg) and average daily weight gain (50.85±3.06 g head⁻¹ day⁻¹). However, there were no significant differences between T₂ and T₃ and between T₃ and T₄ in weight gain. Economic analysis of the feeding packages showed that T₂ was the most economical feed ration with a net return of ETB 99.81. It is recommended that 500 g h⁻¹ d⁻¹ mixed concentrate can be used to finish grazing sheep for market in North Shewa zone by farmers who have access to commercial concentrates.

Key words: Dry season supplement, highland sheep, noug cake, oat grain.

Introduction

Grain and crop residue as well as locally produced liquor residue (*atela*) are used as livestock fattening ration in the central highlands of North Shewa zone of Amhara region. Farmers of Inewari, Deneba, Angolelana Tera, and Minjar Shenkora districts practice market-oriented livestock fattening, which focus on draught oxen, aged cows and castrate rams.

The expansion of arable farming resulted in shortage of grazing lands which led to an increased utilization of crop residues as animal feed. Grazing is in short supply at Deneba and hence animals depend mainly on crop residues and left over. Farmers usually feed crop

residues mostly without any treatment to enhance the nutritive value. However, numbers of studies suggested the advantage of supplementation and multi nutrient blocks in improving intake and digestibility of crop residues. A study conducted at Debre Zeit Agricultural Research Center showed that urea molasses block improved the performance of Arsi Balemale lambs by 41.3 g daily gain (unpublished).

A previous on-farm fattening study at Deneba indicated that supplementation with a high plane diet prepared from locally available feeds (1000 g oat straw, 100 g faba bean, 50 g *Lathyrus sativa* grain, and 450 g oat grain) supported a weight gain of 44.9 g day⁻¹ than a low plane diet (100 g oat straw, 100 g faba bean, 50 g *Lathyrus sativa* grain) which gave 14.5 g day⁻¹ over a 36 week fattening period. A subsequent fattening study at Debre Birhan research center (ILCA, 1989) indicated that adult male highland Menz sheep can be successfully fattened during the dry season if supplemented with a moderate amount of concentrate at a level of 500 g head⁻¹ day⁻¹ (ILCA, 1988). A lower rate of supplement would not produce quality carcasses required by the market (Gautsch and Peters, 1989).

The traditional sheep and oxen fattening practice in North Shewa, particularly in Deneba and Inewari districts, is based on grain supplementation (Anteneh *et al.*, 2006). Farmers in the area can thus adopt grain-concentrate-based feeding packages. Previous studies showed that sheep could be finished within 120 days of concentrate supplementation. However, the traditional fattening practice in the area takes longer period (Anteneh *et al.*, 2006). Development and demonstration of efficient and economical concentrate-based feedlot packages for a market-oriented production system would be especially valuable for areas with limited grazing opportunities and having access to market. The objective of this study was, therefore, to verify three alternative dry season sheep fattening packages suitable to Syadeberna Wayu district.

Materials and methods

The study area

The experiment was conducted at Syadeberena Wayu district at Dawa Kombolcha peasant association. Dawa Kombolcha is located 57 km West of Debre Birhan town at an altitude of 2600 m above sea level. The temperature ranges from a mean minimum of 6 °C to a mean maximum of 18 °C. The annual average rainfall is 880 mm with main (July to October) and short (February to April) rainy seasons. The bimodal rainy season corresponds with two cropping seasons in the area with major crops of wheat, teff, faba bean and check pea.

Experimental design and management

An on-farm feeding trial was carried out for a period of 83 days from end of January to mid April 2008. Sixty yearling ram lambs collected from 19 selected farmers were used for the study. The experimental design was a completely randomized design (CRD) with four experimental groups each with 15 sheep.

1. Free grazing (Farmers practice)
2. Free grazing + 500 g mixed concentrate
3. Free grazing + 150 g noug cake +150 g oat grain.
4. Free grazing + *teff straw* adlib + 300 g noug cake + multi-nutrient block (MNB) adlib.

The concentrate mix (treatment 2) was formulated from 30.75% noug cake (*Guizotia abyssinica*), 50% wheat bran, 18% oat grain, 1% limestone, and 0.25% salt. Each MNB weighed 7 kg and was prepared from 30% molasses, 10% urea, 20% wheat bran, 20% noug cake, 15% cement and 5% salt.

The experimental sheep were vaccinated and dewormed against common diseases and parasites in the area before the start of the experiment. Sick animals were treated during the course of the experiment. All animals were grazed together on the same natural pasture from 8:00-17:30 hrs local time. They were separated into their respective treatment groups every day at 10:30 to receive their daily ration. Then after, all the lambs stayed on pasture

together with the exception of group 4 animals that were offered with MNB indoors. The MNB was introduced gradually but was provided *adlib* after the animals were accustomed to it. All animals were watered once a day. The experiment lasted only for 83 days, which was shorter than the recommended 90-120 days, since the farmers sold the sheep for Easter market.

Data collection and analysis

All animals were weighted at the beginning of the trial. Then after, the animals in the supplemented groups (treatments 2-4) were weighed fortnightly, while those in the control group (treatment 1) were weighed every month. All animals, except those in MNB group, were weighed in the morning after overnight fasting. The amounts of feed offered and refused were recorded daily, except for teff straw and MNB. The data were analyzed using the GLM procedure in SAS (2001). The model included feeding treatment as independent and initial weight, final weight and average daily gain as dependent variables. In order to account for initial differences in body weight among the experimental animals, final weight was adjusted in the analysis by including initial weight as covariate in the analysis model.

Economic data collected included the actual costs of feed (oat grain, noug cake, wheat bran, molasses, salt, limestone, and teff straw) and lambs, and estimated sale price of the lambs by local live animal dealers at the end of the trial. Partial budget analysis was employed to evaluate the economics of the different feeding packages.

Results and discussion

Body weight and dry matter (DM) intake

Results on initial weight, total weight gain, average daily weight gain and final weight are presented in Table 1. There were no statistically significant differences ($P \leq 0.05$) in initial weights among the four treatment groups. All the supplemented groups (T_2 , T_3 and T_4) gained significantly more weight and thus attained higher final weights than the control group (T_1). The supplemented groups gained from 286% to 208% more weight than the control group at the end of the feeding period. Among the supplemented groups, the sheep

in T₂ attained the highest final weight (23.88±0.23 kg) and average daily weight gain (50.85±3.06 g head⁻¹ day⁻¹). However, there were no significant differences between T₂ and T₃ and between T₃ and T₄ in weight gains. All the supplementary feed that was offered to each sheep was completely consumed. Thus the DM feed intake was 100%.

Table 1. Effect of supplemental feeding on the final weight, total weight gain and average daily gains of highland ram lambs at Syadeberena Wayu (Least square means ±SE).

Treatments	Number of sheep	Initial weight (kg)	Final weight (kg)	Total weight gain (kg)	Average daily weight gain (g)
T ₁ -Grazing(G)	15	21.10±0.97	21.11±0.24a	1.49±0.24a	17.23±3.13a
T ₂ -G + 500 g mixed concentrate	15	19±0.97	23.88±0.23b	4.26±0.23b	50.85±3.06b
T ₃ -G +150g oat grain +150g Noug cake	15	18.96±0.97	23.42±0.24bc	3.80±0.24bc	42.63±3.06bc
T ₄ -G + teff straw + 300 g noug cake + MNB	15	18.96±0.97	22.72±0.23c	3.10±0.23c	37.07±3.06c
Over all mean		19.51±0.49	22.77±0.65	3.16±0.65	36.94±1.57
R ² (%)		6	95	57	49
CV (%)		19.35	3.94	28.76	33

Economics of fattening

Economic analysis of the different feeding treatments was conducted to identify a recommended fattening ration for Syadeberena Wayu district and elsewhere with similar conditions. In all economic analyses, labor cost was not considered since there was no specific labor allocated for the feeding practice. Results of the partial budget analysis indicate that T₂ (500 g head⁻¹ day⁻¹ concentrate mix) was the most economical feed ration with a net return of ETB 99.81 (Table 2).

Sensitivity analysis was done to confirm to what extent the result will sustain changes in cost of feeding and animal sale prices assuming a bad expectation. That is, assuming changes towards the worse in input and output prices or in some aspects of the enterprise

that lead to a decrease in the volume of the production. The result showed that profitability of the fattening practice would result in a positive net benefit for the study area up to 10% output price reduction and input price increment from current estimated average output price and input price levels.

Table 2. Partial budgeting and sensitivity analysis for fattening practice at Syadeberena Wayu.

Description	Treatments			
	T1*	T2	T3	T4
Average selling price of fattened animal (ETB head ⁻¹)	114.33	260.71	253	230.67
Average feed cost (ETB head ⁻¹)	0	72.97	76.11	95.32
Average initial animal cost (ETB head ⁻¹)	100.53	87.53	87.2	89.46
Average medical cost (ETB head ⁻¹)	0.4	0.4	0.4	0.4
Total fattening cost (ETB head ⁻¹)	100.93	160.9	163.71	185.18
Net benefit (ETB head ⁻¹)	13.4	99.81	89.29	45.49
Sensitivity analysis				
+ 5% fattening cost (ETB head ⁻¹)	106.00	168.955	171.89	194.44
-5% selling Price of fattened animal (ETB head ⁻¹)	108.61	247.67	240.35	219.14
Net benefit (ETB head ⁻¹)	2.64	78.73	68.45	24.70
+ 10% fattening cost (ETB head ⁻¹)	111.02	176.99	180.08	203.70
-10% selling Price of fattened animal (ETB head ⁻¹)	102.90	234.64	227.70	207.60
Net benefit (ETB head ⁻¹)	-8.13	57.65	47.62	3.91

* $T_1 = \text{Grazing (G)}$, $T_2 = G + 500 \text{ g mixed concentrate}$, $T_3 = G + 150 \text{ g oat grain} + 150 \text{ g Noug cake}$, $T_4 = G + \text{teff straw} + 300 \text{ g noug cake} + \text{MNB}$

Conclusions and Recommendation

Short-term strategic fattening packages based on concentrate supplementation could be feasible in areas where there is shortage of grazing land for extensive livestock production like in Syadeberena Wayu district. Based on our results, it can be recommended that 500 g head⁻¹ day⁻¹ mixed concentrate can be used in the dry season to finish grazing sheep for market in areas similar to Syadeberena Wayu district by farmers who have access to commercial concentrates. An alternative feeding practice, which is also economically competitive to concentrate supplementation, is the feeding of 150 g oat grain and 150 g noug

cake head⁻¹ day⁻¹. Farmers could benefit from these feeding practices with a net benefit of ETB 99.8–89.3 per sheep fattened. The results of the study may have to be verified under wet season condition.

Acknowledgment

We would like to extend our thanks to the Debre Birhan Agricultural Research Center for facilitating in every aspect and extend our deepest gratitude to Ato Tameru Kebret for helping us in many ways during conducting the experiment.

References

- Anteneh, G., Beneberu, T., Likawent, Y. 2006. Economic evaluation of traditional livestock fattening practices under smallholder farmers condition in north Shewa. Proceedings of the first annual regional conference on completed livestock research activities 14 to 17 August 2006. pp. 40-58.
- Getahun Kebede. 2006. Evaluation of the replacement effect of poultry urea molasses block on the performance of growing Arsi–Bale male lambs (Unpublished).
- Shapiro, B., Mohamed–Salim, M.A. and Reynolds, L.1994. Socio–economic constraints to strategic sheep fattening: Evidence from the Ethiopian highlands. Pp. 11-14.

On-farm demonstration of splitting queen rearing technique in Meket woreda, Eastern Amhara

Tessema Aynalem and Wondimagegne Bekele

Abstract

Queen splitting technique was demonstrated in Meket woreda, North Wollo zone where beekeeping is a major farming activity. Farmers participating in the project obtained on average 1.09 new daughter colonies per hive by using the queen splitting technique. Sixty-seven percent of the new daughter colonies have adapted, but 33% of the colonies have absconded due to long lasted severe drought in the area during the experimentation period. The queen splitting technique has been highly accepted by the beekeepers. It is recommended that to encourage farmers and scale up the technique, the extension department need to focus on creating marketing opportunity and links for bee colonies produced by the beekeepers.

Key words: Abscond, beekeeping, daughter colonies, queen splitting.

Introduction

The diversified agroclimatic condition in Ethiopia has created conducive environment for the existence of over 700 species of flowering plants. The high proportions of Ethiopian plants are endemic to the country (Edwards, 1976). The ideal climatic conditions and diversified floral resources allow the country to sustain around 10 million honey bee colonies of which 7 million are kept by farmers and the remaining exist in the forest as wild colonies (EMA, 1981). Beekeeping is the long standing practice in the rural communities of Ethiopia. However, the type of beekeeping practiced in the country is largely traditional using traditional hives of different types which vary depending on the ecology and behaviors of the bees (Nuru, 2007). At present the populations of honey bee colonies are certainly in the state of continuous decline due to various factors. As a result, it has become more difficult to obtain adequate swarms every year to expand the apiary (Nuru, 2007).

In the highlands and mountainous areas of Ethiopia the swarming tendency of the honey bee colonies is very low. As a result, the price of the colony is very high and becoming a

good source of income to beekeepers (Nuru, 2007). In these areas where reproductive swarming tendency is low, one of the major problems of apiculture is obtaining swarms either to start or to increase the existing stock. Thus, in these areas developing simple ways of colony multiplication skills such as splitting queen rearing would be very important. The technique has been proven to be efficient for local honey bee colonies (Nuru and Dereje, 1999). It has been also proven and become effective in Western Amhara and recommended to be done in different potential beekeeping districts of the region where there is promising bee forages and scarcity of the honey bee colonies (Adebabay, 2007). Thus, the objective of the current study was to demonstrate splitting queen rearing technique in Eastern Amhara under farmers' management condition.

Materials and methods

Location and sampling technique

The study was conducted in one purposively selected kebele in Meket woreda of North Wollo zone. Meket woreda is selected for its potential for beekeeping. Nine farmers owning strong honey bee colonies in Kenyan top bar hives were purposively selected. Intensive training on splitting queen rearing technique and standard top bar nucleus hives and protecting clothes were given for participants.

Queen rearing

Nucleus hives were cleaned and smoked with wax and aromatic plants traditionally known and available for farmers. Then the actual splitting of the mother honey bee colonies was undertaken at night using strong torch consecutively by coaching the farmers on checking the presence of eggs and day old larvae, which is potential queen and absence of mother queen during transferring into nucleus hives. The nucleus colonies splitted were put at 100 m to 1 km far from the mother colony to avoid the risk of reuniting. At the 9th to 10th days after splitting the nucleus hive, colonies were checked whether they have been constructed and sealed queen cells. Hence, by leaving the best queen cell, others were harvested and destroyed to control swarming. In order to check the safety of honey bee colonies, internal and external inspection was carried out in both mother and daughter colonies. At 12th to

13th days after the emerging, the queen was checked for starting to lay eggs and the colony was returned to the normal backyard apiary site. When the colonies in the nucleus hives become populous, they were transferred in to the standard Kenyan top bar hives.

Data collection and statistical analysis

The data collected included number of hives multiplied, queens developed/hive, nucleus colonies produced from each parent hive, colonies adapted after splitting, and colonies absconded after splitting. Farmers’ and extension workers’ views on splitting queen rearing technique was also collected through interviews. The collected data was analyzed and interpreted using descriptive statistics. The SPSS (2003) software was used for data analysis.

Results and discussion

Number of honey bee colonies split, adapted and absconded is presented in Table1. Twelve mother honey bee colonies were split by nine beekeepers. Eleven of the mother colonies gave one extra daughter colony each and one gave two daughter colonies.

Table1. Number of honey bee colonies split, adapted and absconded.

	Number of mother colonies split	Number of daughter queens developed	Number of daughter colonies adapted	Number of daughter colonies absconded
Total	11	12	8	4
Mean per hive		1.09	0.67	0.33
Std. Error of mean		0.091	0.141	0.152

Out of the honey bee colonies that gave one daughter colony, 70% of them have adapted and 30% have absconded. In the case of mother colony that gave two daughter colonies, one has adapted and the second has absconded. Out of the total twelve daughter queens that were developed from the eleven mother colonies, 67% have adapted and 33% have absconded due to severe draught that lasted for a long period in the area during the

experimental period. The mean number of queens developed per hive was 1.0 and the mean number of nucleus colonies developed from parent hive was 1.09.

Upon completion of the experiment, field day was organized at the kebele in Meket woreda where the demonstration was conducted. The participants in the field day were the target beekeepers, other invited beekeepers, interested farmers, and development agents from the woreda, and socioeconomics and livestock researchers from Sirinka Agricultural Research Center.

Farmers reflected their view on the new bee colony multiplication technique. They expressed that splitting queen rearing technique is of significant importance to expand existing and establish new apiaries compared to their traditional practice. The traditional method of acquiring new bee colonies has been to wait for wild natural swarms coming from elsewhere to settle in their traditional hives which they hang on very tall trees in the forest, around the farm or homestead. The traditional practice is not convenient, requires climbing up tall trees and not suitable to women beekeepers. Farmers are convinced that the new technique will solve their problem of acquiring new honey bee colonies. The traditional bee keeping practice where new colonies are obtained by catching the swarmed colony during flowering period coincides and thus competes with peak agricultural activities such as weeding, harvesting, and livestock keeping. Besides, the traditional practice is very laborious. Furthermore, the colony takes a longer time to build combs, develop and become strong as the colony obtained is kept in traditional hives. As a result, it is rarely possible to harvest honey from the new colony in the first year of its establishment.

The new queen rearing technique demonstrated in this study also has some drawbacks, but the drawbacks can be compensated. The technique involves splitting a strong colony (either transitional or modern hive) containing seven to ten top bar or frames having a comb with egg, day old larvae and small amount of worker bees to cover the brood comb during the onset of flowering season. Participating farmers complained that this technique reduced the honey yield at the first year of splitting. However, they were convinced that the loss can be compensated by the new colony produced which can be sold as a breeding material or

maintained as a potential honey producer for the coming year. Furthermore, it is also possible to harvest some honey at second cropping period of the first year. The bee keepers thus have a choice in this new technology, either for production of colony or honey. The advantage of the new queen rearing method is that queen rearing depends on the will of the bee keeper not by the natural process of swarming and it also alleviates the problem of pinching the queen abdomen to kill her and helps to produce queen free of damage.

According to farmers, the splitting queen rearing technique can be undertaken in both high and low honey production potential areas. The strategy for low potential areas could be to produce and sell honey bee colonies using the new queen rearing technique to supplement their income. Currently, honey bee colonies worth more than ETB 600. In high honey production potential areas, beekeepers can benefit from selling both colony and honey. The technology uptake is already encouraging as some follower beekeepers which did not participate in the study have already applied the technology by constructing nucleus hives from locally available materials.

Conclusion and Recommendation

Our results strongly indicate that it is feasible to rear queens by splitting the colony under farmers' condition. The demonstrations also showed that the technique is acceptable and very easy to apply by smallholder bee keepers. The work needs further scaling up across different honey bee production potential areas of the region by using strong mother colonies during the onset of flowering season. The focus by the extension department should be on creating marketing opportunity and market links for honeybee colony producers adopting the new technology.

References

Adebabay Kebede, Keralem Ejigu and Assaminew Tassew. 2007. Onfarm evaluation of colony splitting technique in Amhara region. In proceeding of the 2nd annual regional conference on completed livestock research activities 14 to 16

- September 2007. pp 64-70, Amhara agricultural research institute, Bahir Dar, Ethiopia.
- Edwards, S. 1976. Some wild flowering plants of Ethiopia. Addis Ababa university press, Addis Ababa, Ethiopia.
- EMA (Ethiopian Mapping Agency). 1981. National Atlas of Ethiopia. EMA, Addis Ababa, Ethiopia.
- Nuru Aadgaba and Dereje Wolteji. 1999. Response of Ethiopian honey bee colonies to different queen rearing techniques. In proceeding of 7th Annual conference of Ethiopian society of animal production. Addis Ababa, Ethiopia. pp 125-133,
- Nuru Aadgaba. 2007. Atlas of pollen grains of major honey bee flora of Ethiopia. Holleta Bee Research Center, Holleta, Ethiopia.
- SPSS (Statistical package for social science). 2003. SPSS user's Guide 12.0, SAS institute inc.

Demonstration of maize and noug cake mixture supplementation for women-focused small scale sheep fattening in Yilmana Densa woreda

Simegnew Tamir, Habtemariam Assefa, Shigdaf Mekuriaw and Wude Tsega

Andassa Livestock Research Center, P.O.Box 27, Bahir Dar, Ethiopia

Abstract

The study was conducted in 2009 at Adet zuria kebele of Yilmana Densa woreda, Amhara Regional State. The fattening project was conducted with six women participants. Each participant bought three yearling Washera sheep from Adet market. The sheep were maintained on grazing for five hours a day and supplemented with 400 g concentrate head⁻¹ day⁻¹ before and after grazing for a fattening period of three months. The concentrate mixture was composed of 24.75% maize grain, 74.25% noug cake and 1% salt. Supplementation with 400 g concentrate increased the average weight of the sheep from 26.88 kg to 33.56 kg. The average daily weight gain was 80.5 g, ranging from 21.7 g to 125.3 g. A simple financial analysis indicated that fattening of sheep using 400 g noug cake and maize mixture was economical with a gross profit of ETB 96.74 per sheep. The fattening technology was demonstrated to invited farmers and experts from the woreda office of agriculture. It is recommended that the technology should be scaled out for wider use by farmers targeting festival markets.

Key words: Fattening, maize, noug cake, Washera sheep.

Introduction

Women in developing countries have greater role in agriculture production activities. However, the roles of women in agriculture have not been appreciably recognized by the society. Research findings indicated that women's role in agriculture account for more than 50% of the agricultural activities, particularly in developing countries (African Farmer, 1993). Empowering women in sheep fattening can develop their self-esteem in decision making and can increase their livelihood income.

In most parts of the Amhara region, the available feed resources during the dry season are degraded natural pasture and low quality crop residues which cannot meet the maintenance requirement of the animals, let alone their fattening requirements. As a result, farmers

commonly market animals that are in poor body condition. This results in low income to farmers from animal sales and supply of low quality and quantity of meat to consumers. Hence, introducing and demonstrating promising fattening practices using alternative available feed resources can improve body condition of marketed animals, thereby increasing meat yield and consequently income of the farmers, particularly for the women.

Previous studies on fattening of a similar sheep breed (Horro sheep) indicated that concentrate supplementation of yearling Horro rams with 400 g head⁻¹ day⁻¹ and grazing for about three months was economical. Solomon *et al.* (2005) reported that supplementation of 400 g head⁻¹ day⁻¹ maize and noug cake mixture resulted in good and economical growth response in Horo sheep. The objectives of the current study were, therefore, to demonstrate maize and noug cake mixture supplementation for washera sheep fattening and to empower women in sheep fattening practice and its marketing system.

Materials and methods

The study area

The study was conducted at Adet Hana (Zuria) Kebele, Yilamana Densa woreda in the Amhara Regional State. The kebele was selected based on accessibility to market and participant women interest by development agents and researchers.

Participating farmers and experimental animal management

The study was conducted between February and April, 2009 with women participants. Six women were selected and trained together with the kebele development agent on sheep production, marketing, management, fattening and health management and prevention methods. Following training and discussion, farmers agreed to avail sheep for the study and to fatten the animals individually in their own farm.

Each participant bought three yearling Washera sheep from Adet market with the assistance of experts during season of low market price. Before starting the fattening, the animals were dewormed against internal parasites and vaccinated against sheep pox and

pasteurellosis. Feeding was done using troughs. Supplemental feed and medicaments were provided by Andassa Livestock Research Center. The sheep were maintained on grazing for five hours a day and supplemented with 400 g concentrate head⁻¹ day⁻¹. The concentrate mixture was composed of 24.75% maize grain, 74.25% noug cake and 1% salt. Provision of the concentrate supplement was split into two feeding time, 200 g before grazing and 200 g after grazing. The fattening period lasted for three months. The fattened animals were sold for Easter at Adet market.

Data collection and analysis

Data collected included initial body weight, final body weight, cost of fattening (feed cost, animal purchasing and medicament cost), and animal sale prices. Farmers' and experts' opinions were gathered during field day organized to demonstrate results of the fattening study. The body weight data was analyzed using GLM model using SPSS software version 16. The economic benefit of the fattening practice was estimated using a simple financial analysis.

Results and discussion

Body weight change

Results showed that grazing sheep supplemented with 400 g concentrate increased the average final body weight from 26.88 kg to 33.56 kg (Table 1). The average daily weight gain was 80.5 g day⁻¹, ranging from 21.7 g to 125.3 g. The weight gain achieved in the current on-farm demonstration was close to but lower than reported by Solomon *et al.* (this proceeding) for Washera sheep fattening under on-station condition which resulted in average daily weight gain of 101 g with a range of 38 to 126 g head⁻¹ day⁻¹. The difference could be due to differences in the supplement feed used in the on-station study, which was a mix of grass pea (*Lathyrus sativus*) and maize grain (*Zea mays*) at the ratio of 4:1, and a more controlled feeding under on-station conditions.

Table 1. Washera sheep body weight change in a feeding trial at Adet.

Parameters	No of animals	Mean body weight	Standard Error
Initial body weight (kg)	18	26.88	0.67604
Final body weight (kg)	18	33.56	0.56152
Daily body weight gain (g)	18	80.52	6.72512

Farmers and experts perception

At the end of the fattening period, field day was organized to demonstrate the results to non-participating farmers and woreda agricultural experts. The feedback from the participants of the field day was positive. Participants appreciated the fattening technology and commented that the new technology is superior to the traditional fattening practice in terms of reducing cost, time of fattening, and labor. They also commented that future research should focus on fattening castrated sheep which are highly preferred by the market.

Financial benefits

Results of the financial analysis showed that the gross profit per sheep fattened was ETB 96.74 (Table 2). The marginal revenue indicated that one ETB investment on inputs for fattening sheep provided gross profit of ETB 1.30. This result is in agreement with the results of the Horro sheep fattening study (Solomon *et al.*, 2005).

In order to test the profitability of the current fattening package in the future, a sensitivity analysis was conducted varying the cost of inputs and outputs. Profitability was assessed assuming a rise in input costs and a decline in output prices 10%. The result of sensitivity analysis indicated that fattening of sheep with 400 g noug cake and maize mixed supplementation was still profitable with gross profit of ETB 23.30 and marginal revenue of ETB 1.07.

A sensitivity analysis was conducted varying the cost of inputs and outputs in order to test the profitability of the current fattening package in future. Profitability was assessed

assuming a rise in input costs and a decline in output prices by 10%. The result of the sensitivity analysis indicated that fattening of sheep with 400 g noug cake and maize mixed supplementation was still profitable with a gross profit of ETB 23.30 and marginal revenue of ETB 1.07 (Table 2).

Table 2. Financial benefits per fattened sheep.

Items	Amount in ETB per sheep
1. Benefits from sheep fattening	
• Sheep sale	415.56
Total gross benefit (A)	415.56
2. Input Cost	
• Sheep purchase	239.44
• Feed cost	62.37
• Medication cost	17.00
Total Input cost (B)	318.81
3. Gross Profit (A-B)	96.74
4. Marginal Revenue(A/B)	1.30
5. Sensitivity Analysis (10%)	
• Total Gross Benefit	374.00
• Total Cost of Fattening	350.70
• Gross Profit	23.30
• Marginal Revenue	1.07

Conclusion and Recommendations

The study indicated that fattening of yearling Washera sheep with supplementation of 400 g concentrate composed of 74.25% noug cake, 24.75% maize grain and 1% salt is profitable with an average gross profit of ETB 96.74. According to farmers' opinions, the Ethiopian traditional market prefers castrated fattened rams related to social customs and values. Therefore, future research should focus on castrated ram fattening technologies. It is recommended that the current technology can be adopted by the extension department and scaled up to other similar woredas targeting festival markets.

References

- Shapiro, B.I., Mohamed-Saleem, M.A., and Reynolds, L. 2006. Socio-economic constraints to strategic sheep fattening: Evidence from the Ethiopia highlands. International livestock Center for Africa. Ethiopia.
- Devendra, C. and Mcleroy, G.B. 1982. Goat and sheep production in the tropics. Intermediate tropical Agricultural series.
- Margarit, S., Mulenga and Lawerence.1993. African Farmer. The Hunger project. New York.
- Solomon Gizaw, Solomon Abegaze and Asfaw Negassa. 1991. Growth response of Horo sheep to different levels maize and noug cake Supplements. P 113-117. In: Proceedings of 4th National Livestock Improvement Conference, 13-15 November 1991, Addis Abeba, Ethiopia.
- Solomon Abegaz, Gameda Duguma, Takele Kumsa, Birhanu Soboka, Dereje Bacha, Bizunesh Mideksa, Fayo Dubiso, Ulfina Galmessa and Birhan Feleke. 2005. On-farm verification of sheep finishing technology in Eastern Wollega zone. Proceedings of the 12th Annual conference of the Ethiopian Society of Animal Production (ESAP) Addis Ababa, Ethiopia, August 12-14, 2004. ESAP 410.pp.

Characterization of Gumuz sheep under traditional farmer practice in Metema woreda of Amhara Regional State

Solomon Abegaz¹ and B.P. Hegde²

¹Gondar Agricultural Research Center, P.O.Box 1337, Gondar:

²Haremaya University, P.O.Box 287, Haramaya

Abstract

The objective of this study was to describe the physical, reproductive and growth characteristics of Gumuz sheep breed. The study was conducted at Metema Woreda of the Amhara National Regional State in Ethiopia. The coat color patterns of Gumuz sheep are plain (50.5%) including white, reddish brown, black, brown or grey, patchy (29.5%) and spotted (20%) with above color combinations. The tail is thin, having convex head profile and wattle is absent in both sexes. In 86% of males the horn is rudimentary or absent and females are polled. In mature females and males, the average body length was 66.95 cm and 68.31cm, height at wither was 63.59 cm and 67.31 cm and chest girth was 76.07 cm and 77.94 cm, respectively. In the 27 monitored flocks, breeding male to female ratio was 1:6.7 and females of breedable age formed 47.8% of the flock with average litter size of 1.17. The average birth weight was 2.79 ± 0.028 kg and males, single born lambs and lambs born to later parity ewes were significantly heavier than females, twin born lambs and lambs born in first or second parity. The average weight of lambs at one, two and three months, one and one and a half years were $6.61 \pm .15$ kg, $7.74 \pm .22$ kg, $12.64 \pm .24$, 05 ± 6.53 , and 29.5 kg, respectively. The average weight at one and half years was statistically similar to weights at the later age groups. The average marketing age was less than one year. Comparing to other breeds, the Gumuz ewe produce large number of progeny in her lifetime and males grow fast, which indicated that the breed has good potential for meat production.

Key words: Birth weight, body measurement, coat color, Gumuz sheep, lamb, twin.

Introduction

Ethiopia is known for its large population of livestock and diverse agro-ecology. The population of livestock is estimated as 41,527,142 cattle, 14,655,565 sheep, 13,661,562 goats, 1,504,208 horse and 3,962,969 asses (CSA, 2003). Sheep in particular have a great role in the economy of the farming population of Ethiopia. Sheep and sheep products are the major source of cash income for the farming community. In addition, sheep are raised

mostly to safeguard against crop failure and unfavorable crop prices in intensive cropping areas.

Despite the large size of the country's sheep population, the productivity per unit of animal and the contribution of this sector to the national economy is relatively low. This may be due to different factors such as poor nutrition, prevalence of diseases, lack of appropriate breed and breeding strategies. However, the indigenous sheep breeds of Ethiopia have relative advantage in their natural habitat to which they are well adapted. Sheep types in Ethiopia have been identified (Sisay, 2002; Solomon and Gemedo, 2004; Workneh *et al.*, 2004; Solomon, 2008). However, many of the recognized breed types including Gumuz breed have no population estimates and description of physical, physiological and functional characters and their status as a breed is not known. On-farm and on-station characterization of the merits and demerits of the identified breed types is indispensable to design sustainable genetic improvement, conservation and management strategies. The objectives of this study were, therefore, to characterize the physical feature and to evaluate some of the reproductive and production performance of Gumuz sheep under on-farm condition.

Materials and methods

The study area

The study was conducted in Metema woreda of the Amhara National Regional State. It is located about 900 km Northwest of Addis Ababa and about 180 km West of Gondar town. The altitude of Metema ranges between 550 and 1608 meters above sea level, while the minimum annual temperature ranges between 22 °C and 28 °C. Daily temperature is very high during the months of March to May, where it might reach as high as 43 °C. The mean annual rainfall of the area ranges between 850 to around 1100 mm.

Physical features

Based on the typical breed character as recognized by farmers, 114 female and 58 male Gumuz sheep were selected to characterize the physical features of the breed. Based on

FAO (1986) physical descriptors list; color, head profile, ears, wattle, horns, beard, tail and ruff were observed. Linear body measurements including chest girth (CG), body length (BL), height at wither (HW), ear length (EL), tail length (TL) and horn length (HL) were measured.

Growth and reproductive characters

Twenty-seven Gumuz sheep flocks with a total of 249 animals were selected, ear tagged and monitored for a detailed characterization of growth and reproductive performances. Birth weight and fortnightly weight of lambs were measured during a four month study period (end of September to end of January).

Statistical analysis

Physical features were analyzed using descriptive statistics. The General Linear Model (GLM) procedure of SAS (1999) was used to analyze the growth traits where sex, parity and type of birth were taken as fixed effects. Duncan's multiple range tests was used to establish the statistical significance of differences between means following Gomez and Gomez (1984).

Results and discussion

Qualitative characters of Gumuz ewes and rams

Gumuz breed is a thin tailed breed with varying coat color (Figure 1). The coat patterns of female sheep were 41.2% plain, 32.5% spotted and 26.3% patchy. Reddish brown and white (30.7%), black and white (20.2%) and reddish brown (16.6%) were the most frequent colors among the female sample population. All females were without horn and ruff. Head profile was mostly convex (93%). They have long and semi pendulous ears and wattles are generally absent.

The coat color patterns in males include 60.3% plain, 25.9% patchy and 13.8% spotted coat pattern (Figure 1). Plain white (27.6%), reddish brown and white (19 %) and black and white (17%) coat color patterns were dominant. Reddish brown, black, brown and grey coat

were also observed in plain pattern and mixed in patchy or spotted patterns. In males, 13.8% and 20.7% of the sample population have horn and rudimentary horn, respectively and the rest (65.5%) had no horns. Ruff was present in 63.8% of male population. Wattle was rarely observed and head profile was mostly convex.



Figure 1. Gumuz ewe (left) and ram (right).

Body measurement and weight of Gumuz ewes

The results of the linear body measurements and body weights of Gumuz ewes indicated that the average body weight, body length, height at wither and chest girth were 31.41 kg, 65.95 cm, 63.59 cm and 76.07 cm, respectively (Table 1). Tail length and ear length were 34.46 cm and 11.59 cm, respectively (Table 1).

Table 1. Average body measurements and weight of Gumuz ewes.

Traits	N	Minimum	Maximum	Mean	SD.
Body weight (kg)	114	22	42	31.4	3.935
Body length (cm)	114	61	72	65.95	2.456
Height at wither (cm)	114	55	70	63.59	2.831
Chest girth (cm)	114	67	84	76.07	4.004
Tail length (cm)	114	25	44	34.66	3.165
Ear length (cm)	114	7	14	11.59	1.055

The average body weight, body length, height at withers and chest girth of this sheep breed are higher than the values obtained for other breeds of central highland and Rift Valley of the Amhara Region by Sisay (2002) and Menz sheep by Markos *et al.* (2004). But, they are

almost equal to the measurement obtained for Washera sheep of Northwestern highlands by Sisay (2002) and comparable to the measurement obtained for Horro sheep by Markos *et al.* (2004).

Body measurement and weight of Gumuz rams

The results of the linear body measurements and body weights of Gumuz rams are presented in Table 2. The average body weight of Gumuz ram (34.63 kg) is heavier than the average body weight of central highland sheep breeds (29.43 kg), Rift valley sheep (27.46 kg), Northwestern highland sheep (31.4 kg) and Menz sheep (25.3 kg) (Sisay, 2002; Markos *et al.*, 2004). The average chest girth height at withers of Gumuz rams are also higher compared to the central highland and Rift Valley sheep. The central highland and Rift valley sheep are 64.72 cm and 60.4 cm height at wither where as the Gumuz had 67.31 cm height. The Gumuz breed was also longer (68.31cm) in body length compared to the central highland (61.3 cm), Rift valley (55.78 cm) and northwestern highland sheep (65.16)(Sisay, 2002).

Table 2. Average body weight and body measurement of Gumuz rams.

Traits	N	Minimum	Maximum	Mean	SD
Body weight(kg)	35	26	50	34.63	6.765
Body Length (cm)	35	60	77	68.31	3.771
Chest Girth (cm)	35	66	87	77.94	4.911
Height at Wither (cm)	35	59	77	67.31	4.143
Tail length (cm)	35	23	48	35.23	5.253
Ear length (cm)	35	9	16	11.93	1.441
Horn length (cm)	5	12	16	14.40	1.817

Litter size

Forty-one male and 45 female lambs were born during the four month monitoring of the sample Gumuz sheep population. Twenty-six lambs were born as twins, which is equivalent to a litter size of 1.17 per ewe. The observed litter size in Gumuz sheep is higher than the litter sizes of 1.02 (Niftalem, 1990) and 1.03 (Abebe, 1999) reported for Menz sheep.

Birth weight

The observed average birth weight for Gumuz breed (Table 3) is higher than the reported values of 2.5 kg for Horro (Rege *et al.*, 1996), 1.76 kg for Menz (Abebe, 1999) and 2.33 kg for another local breed (Aden, 2003). However, average birth weight of Adal and Black Head Somali lambs (Beniam, 1992) were slightly heavier than the average obtained for Gumuz sheep in the present study.

Table 3. Least square means (\pm SE) for birth weight of Gumuz lambs.

Variable	N	Birth weight (kg)
		Mean \pm SE
Overall	86	2.79 \pm 0.028
Parity		***
1	19	2.49 \pm .043 ^{a†}
2	18	2.66 \pm 0.039 ^a
3	28	2.87 \pm 0.031 ^b
4	14	2.94 \pm 0.045 ^b
5	7	2.80 \pm 0.073 ^b
Sex		***
Male	41	2.86 \pm 0.036 ^a
Female	45	2.67 \pm 0.031 ^b
Type of birth		***
Single	60	2.88 \pm 0.028 ^a
Twin	26	2.64 \pm 0.041 ^b

[†]Means within each sub-class with different superscripts differ significantly. *** denotes significant difference at $P \leq 0.001$.

The results of the analysis of variance revealed that male lambs were heavier than females at birth ($P \leq 0.001$) and this is consistent with numerous earlier reports (Niftalem 1990; Kassahun, 2000; Gameda *et al.*, 2003). Lambs born of young ewes in their first and second parity were significantly ($P \leq 0.001$) lighter than lambs born of older ewes. This result is in agreement with earlier findings for other breeds (Gameda *et al.*, 2003; Kassahun, 2000; Aden, 2003). Single born lambs were significantly ($P \leq 0.001$) heavier than twin born lambs.

Pre-weaning growth

Body weights at one, two and three months (weaning) of age are given in Table 4. During the first 30 days lambs gained around 4 kg and during the second and the third 30 days the gain was about 3 kg each. Analysis of variance showed that the effect of parity on lamb weights after birth is insignificant. Similarly, the effect of type of birth remained only up to one month of age.

Table 4. Least squares means (\pm SE) of pre-weaning lamb weight (kg) at specified age.

Variable	Age (month)					
	One month		Two months		Three months	
	N	Mean \pm S.E	N	Mean \pm S.E	N	Mean \pm S.E
Overall	70	6.61 \pm .154	63	9.74 \pm .22	44	12.64 \pm .24
Parity		NS		NS		NS
1	15	6.18 \pm 0.29	13	9.16 \pm .44	7	12.54 \pm .54
2	14	6.04 \pm 0.34	14	9.48 \pm .41	10	12.41 \pm .41
3	23	6.75 \pm 0.22	19	10.02 \pm .35	17	12.67 \pm .32
4	10	6.72 \pm 0.33	9	9.95 \pm .51	5	13.44 \pm .61
5	8	6.7 \pm 0.36	5	9.58 \pm .53	5	11.84 \pm .58
Sex		**		*		*
Male	32	6.86 \pm .21 ^{a*}	28	10.19 \pm .32 ^a	22	13.23 \pm .31 ^a
Female	38	6.10 \pm .19 ^b	35	9.08 \pm .27 ^b	22	12.04 \pm .32 ^b
Type of birth		*		NS		NS
Single	52	6.82 \pm 0.15 ^a	47	9.93 \pm .22	32	12.81 \pm .24
Twin	18	6.13 \pm .26 ^b	16	9.34 \pm .38	12	12.18 \pm .41

*Means Within each sub-class with different superscript letter differ significantly. NS, * and ** denot non significant difference and significant difference at $P \leq 0.05$ and $P \leq 0.01$, respectively.

Post weaning growth

Based on ages estimated from dentition classes, weights of different age classes beyond three months of age are given in Table 5. The mean weight for lambs <6 months is roughly equal to the adjusted three month weight (Table 5). Lambs <6 months and 6-12 months old were significantly lighter than older animals ($P \leq 0.001$). However, there were no significant differences among the older age groups. Thus, it can be estimated that Gumuz sheep attain

their mature weight around 13-18 months of age. This finding draws support from a report that the thin tailed sheep attain mature weight starting from two permanent teeth (Sisay, 2002).

Table 5. Least square means (\pm SE) weight (kg) of Gumuz sheep at different age category.

Variable	N	Mean \pm SE
Category		
<6 month	67	12.3 \pm .798 ^a *
6-12 month	40	23.05 \pm .645 ^b
13-18 month	36	29.5 \pm .923 ^c
19-24 months	41	32.39 \pm .571 ^c
25-48 months	35	34.14 \pm .776 ^c
>48 months	28	33.96 \pm .603 ^c

*Means with different superscript letters differ significantly at $P < 0.001$.

Conclusion and Recommendations

Gumuz sheep breed is one of the thin tailed sheep breeds of Ethiopia. The coat color pattern of the breed varies and includes plain, patchy or spotted patterns with white, reddish brown, black, brown or grey hair. The head profile is convex, without wattles. The males have rudimentary horns or polled while the females are polled. The ewes have better mothering ability in terms of birth weight, rate of gain up to weaning and the animals attain high market weight at an early age. All these evidences demonstrate that Gumuz sheep breed has good potential for meat production under the prevailing harsh environmental condition of Metema.

It is recommended that to validate the conclusions drawn from the current preliminary on-farm study, it is important to undertake a well planned and controlled on-station study to evaluate the genetic potential of Gumuz breed for meat production. Secondly, in order to improve Gumuz sheep farmers' income and to conserve the breed, it is important to design and implement appropriate community-based genetic improvement program for Gumuz sheep breed.

References

- Abebe Mekoya. 1999. Husbandry practice and productivity of sheep in Lalo-Mama Midir woreda of central Ethiopia. M.Sc Thesis presented to the School of Graduate Studies of Alemaya University of Agriculture, Dire Dawa, Ethiopia. 91p.
- Aden Tekle. 2003. Evaluation of local sheep under traditional management around rural area of Dire Dawa. M.Sc Thesis presented to the School of Graduate Studies of Alemaya University, Dire Dawa, Ethiopia. 128p.
- Beniam Akalu. 1992. Production performance of Adal and Black Head Somali sheep under irrigated conditions at Melka Werer. M.Sc Thesis presented to the School of Graduate Studies of Alemaya University of Agriculture, Dire Dawa, Ethiopia. 90p.
- CSA (Central Statistic Authority). 2003. Statistical report on farm management practice, livestock and Implements. Part II, CSA, Addis Ababa, Ethiopia.
- FAO (Food and Agriculture Organization of United Nation). 1986. Sheep descriptors. pp. 58-95. In: Animal Genetic Resource Data Banks. 2. Descriptor Lists for Cattle, Buffalo, Sheep and Goats. Animal Production and Health paper N.50/2. FAO, Rome, Italy.
- Gemeda Duguma, Schoeman, S.T., Cloete, S.W.P. and Jordan, G.F. 2002. The effect of non- genetic factors on pre-weaning survival rate in the Tygerhoek Marine lambs. *Eth. J. Anim. Prod.* 2 (1): 141-148.
- Gomez, K.A. and Gomez, A.A. 1984. *Statistical Procedures for Agricultural Research*. John Willey and sons, Inc., Singapore. 680p.
- ILCA (International Livestock Center for Africa). 1990. *Livestock Research System Manual*. ILCA, Addis Ababa, Ethiopia. Part I. 287p.
- IPMS (Improving Productivity and Market Success). 2005. *Metema Learning Site Diagnosis and Program Design*. (unpublished), ILRI (International Livestock Research Institute), Addis Ababa, Ethiopia.
- Kassahun Awgichew. 2000. Comparative performance evaluation of Horro and Menz sheep of Ethiopia under grazing and intensive feeding condition. PhD Dissertation Humboldt-University. 129p.

- Markos Tibbo, Workneh Ayalew, Kassahun Awgichew, Ewnetu Ermias and Rege, J.E.O. 2004. On-station characterization of indigenous Menz and Horro sheep breeds in the central highlands of Ethiopia. *AGRI*, 35: 61-74.
- Niftalem Dibessa. 1990. On farm study of the reproduction and growth performance of Menz Sheep around Debre Brihan area. M.Sc Thesis presented to the School of Graduate Studies of Alemaya University of Agriculture, Dire Dawa, Ethiopia. 103p.
- Rege, J.E.O., Tembely, S., Mukasa-Mugerwa, E., Sovani, S., Anindo, D., Lahlou-Kassi, A. and Baker, R.L. 1996. Preliminary evidence for genetic resistance to endoparasites in Menz and Horro lambs in the highlands of Ethiopia. pp. 37-41. In: Lebbie, S.H.B. and Kagwini, E. (ed.). *Small Ruminant Research and Development in Africa. Proceedings of the Third Biennial Conference of the African Small Ruminant Research Network, UICC, Kampala, Uganda, 5-6 December 1994.* ILRI (International Livestock Research Institute) Nairobi. Kenya.
- SAS. 1999. SAS user Guide, statistic. SAS Institute Inc. Cary. North Carolina, USA.
- Sisay Lemma. 2002. Phenotypic classification and description of indigenous sheep type in the Amhara National Regional State of Ethiopia. M.Sc. Thesis, University of Natal, Pietermarizburg. 104p.
- Solomon Gizaw. 2008. Sheep resources of Ethiopia: genetic diversity and breeding strategy. PhD Thesis, Wageningen University.
- Solomon Abegaz and Gemedo Duguma. 2004. Status and strategies for genetic improvement programs on sheep in Ethiopia. pp. 73-80. In: *Proceeding of the 11th Annual Conference of Ethiopian Society of Animal Production (ESAP).* August 28-30, 2004. Addis Ababa, Ethiopia
- Workneh Ayalew, Ephrem Getahun, Markos Tibbo, Yetnayyet Mamo and Rege, J.E.O. 2004. Current states of knowledge on characterization of farm Animal Genetic Resource in Ethiopia. pp. 1-21. In: *Proceeding of the 11th Annual conference of Ethiopian Society of Animal Production (ESAP).* August 28-30, 2004. Addis Ababa, Ethiopia.

Feedlot weight gain and carcass production efficiency of Washer sheep under concentrate supplementation

Solomon Gizaw¹, Tesfaye Getachew¹, Sisay Lemma¹, Mengiste Taye², Ayele Abebe², Beneberu Tefera²

¹Debre Birhan Agricultural Research Center

²Andassa Agricultural Research Center

Abstract

The objective of this study was to evaluate the fattening potential of Washera ram lambs and to determine economic level of concentrate feed for fattening. Sixty nine month old ram lambs were used for the experiment. Animals were allocated to six feeding treatment groups: a control group maintained on grazing alone and five groups supplemented with 300, 400, 500, 600 and 700 g day⁻¹ of concentrate feed in addition to grazing. Two feeding durations (3 and 4 months of feeding) were considered. Extending the feeding period to 4 months resulted in a decline of 12.6% in overall average daily gain (ADG) and an insignificant increase of 2.8% in final weight (FW) compared to 3 month feeding. Over a 3 month feeding period, FW and ADG varied from 24.9 to 32.9 kg and from 38 to 126 g day⁻¹, respectively. Supplementation of 500 g day⁻¹ resulted in higher ADG and FW compared to lower levels of concentrate feeding. However, there was no difference among groups supplemented with 500 g day⁻¹ and above. Similarly, the supplemented groups had significantly higher carcass weight, dressing percentage, fat thickness and rib eye muscle area compared to the non-supplemented group, though differences among the different levels of supplementation were not consistent. The highest net economic benefit (ETB 151.6 per sheep) was obtained from sheep fattening based on 500 g day⁻¹ concentrate feeding for 3 months. Sensitivity analysis indicated that profitability of this treatment would remain positive up to 20% output price reduction and input price increment. The current results show that Washera sheep has a high feedlot performance and meets an export market demand of around 30 kg at yearling age. Supplementation of 500 g day⁻¹ concentrate feed for 93 days during the dry season for an economic feedlot operation targeting local markets is recommended. The proportion of the tail to the total carcass weight was significantly higher in the supplemented groups than in the non-supplemented group indicating wastage of energy on the less edible portion of the carcass. Thus future research could focus on diverting the energy expenditure in fat deposition in the tail region to the leg and shoulder region. Ration formulation based on locally available forage and/or cheaper feed resources to replace the concentrate feed recommended here could result in a more profitable feedlot operation. Demonstration to Washera sheep farmers and commercial feedlot operators is recommended in order to promote these feeding technologies.

Key words: Carcass, concentrate feeding, economic ration, Washera sheep, weight gain.

Introduction

Washera, also known as Agew or Dangla, is a short-fat-tailed, short-haired, predominantly brown, and polled sheep breed indigenous to Ethiopia. It is one of the most productive sheep breeds in the country with large body size (Solomon *et al.*, 2008) and litter size of 1.11 (Mengistie, 2008). The breed mainly inhabits the wet, warmer mid-highlands (1600-2000 m. a.s.l.) of the Amhara Regional State (W. Gojjam, E. Gojjam, and Awi zones, and Alefa Takusa district in N. Gondar zone) and Benishangul-Gumuz Regional state (Dangur and Madura districts), in northwestern highlands of Ethiopia (Solomon *et al.*, 2008; Sisay 2009). The sheep are an important source of livelihoods for the local farmers with a potential to support the national economy because of its fast growth potential.

Though Washera sheep is known for its fast growth and large body size, the feedlot performance of the breed has not been studied. Under traditional smallholder management system yearling weight of Washera sheep is reported to be 24 kg (Mengiste, 2008). The predominant fattening practice followed in the area is to castrate the lambs at 8-12 months of age and supplement with grass pea (*Lathyrus sativus*) and maize grain. However, the daily amount and frequency of supplementation is inadequate resulting in a longer period of fattening that might render the activity less economical. Moreover, the potential of the breed might be under exploited. Thus management interventions such as improved feeding practices need to be devised to exploit the breed potential. The objectives of this study were to assess the feedlot performance, carcass production efficiency and potential of Washera sheep to meet export sale weight of requirement of 30 kg around yearling age and to identify optimum concentrate feed level for feedlot operators.

Material and methods

Animals and their management

The experiment was conducted at Andassa Livestock Research Center. Sixty ram lambs of about 9 months old bought from the local markets were used for the experiment. The experimental animals were allocated into six feed treatment groups randomly after

stratifying by their initial body weight. The first treatment group was control which was maintained with grazing only while the rest 5 groups were supplemented with 300, 400, 500, 600 and 700 g head⁻¹ day⁻¹ concentrate feed, respectively in addition to grazing. All animals were grazed together during the day and the supplementary concentrate feed was provided individually twice a day before and after grazing. The concentrate mix was grass pea (*Lathyrus sativus*) and maize grain (*Zea mays*) at a ratio of 4:1. The concentrate feed had 21% crude protein and 14 MJ kg⁻¹ metabolizable energy on dry matter basis.

Body weight and carcass measurements

Initial live weight and fortnightly weights were recorded for each animal. Weights recorded at the 93rd (3 month feeding period) and 121st (4 month feeding period) day of feeding were used for analysis of weight gains. Body condition score was recorded for each animal at the end of the experiment. At 121 days, 5 sheep from each treatment were randomly selected for carcass evaluation. Carcass dissection was done as follows. After bleeding and removal of digestive tract and non-carcass components, hot carcass weight was recorded. The whole carcass was separated into two halves (fore and hind quarters) between 12th and 13th rib. Then the whole carcass was divided into five commercial cuts (shoulder, ribs, loin, leg and tail) after removal of the flank part and weighed separately. Tail was removed from the hind quarter. The loin and legs are separated just in front of the hip bones by cutting through the back where the curve of the leg muscles blends into the loin. Finally foreleg, shoulder and neck separated from the ribs. Fore leg, shoulder and neck was measured together and considered as shoulder. Dressing percentage was calculated on hot carcass weight basis and expressed as proportion of final weight before slaughter. Fat thickness and rib eye muscle area were measured at the longissimus between 11th and 12th rib using plastic ruler and planimeter, respectively.

Data analysis

The data were analyzed fitting a general linear model using SAS (2003), with concentrate level as main effect and final weight, average daily gain, carcass weight and dressing percentage as response variables and initial live weight as covariable. The covariate was kept in the model only when significant. Least square means were separated using adjusted

Tukey-Kramer test. Partial budget and sensitivity analysis was employed to assess profitability and sensitivity of the recommendations with fluctuations in feed cost and sheep price. Carcass weight gain at 93 and 121 days for cost benefit analysis was estimated based on the dressing percentage obtained for each feed level. The carcass price used in this analysis was ETB 45 kg⁻¹ for the non-supplemented and ETB 50 kg⁻¹ for supplemented group considering the current sheep mutton price. Only feed cost was considered as a variable cost in the analysis since the other costs (like labor and medicine costs) were similar for all treatment groups.

Results and discussion

Feedlot weight gain

The effect of concentrate supplement for 93 and 121 days on weight gain of Washera sheep is presented in Table 1. There were no difference between feeding for 93 and 121 days in final body weight and average daily gain. In both feeding durations, final body weight and average daily gain significantly increased ($P<0.05$) as feed amount increased from 0 to 500 g. There was no difference in final live weight and average daily gain among groups supplemented 500 g and above. Final weight and average daily gain of the control group was 3 folds lower than the 500 g supplemented group. Thus 500 g concentrate day⁻¹ head⁻¹ was the optimum level of supplement for fattening of Washera sheep. At this level of supplement, final weight and average daily gain at 93 days were 32.0kg and 119 g day⁻¹, respectively. Improvement of live weight, average daily gain and body condition through concentrate supplement is in agreement with other studies in sheep (Solomon *et al.*, 2006; Archimede *et al.*, 2008). Final weight and average daily weight gain attained by Washera sheep in this study is higher than the result for yearling Menz sheep (26.1 kg and 70 g day⁻¹, respectively) fed on 500 g day⁻¹ of concentrate supplement (Solomon *et al.*, 2006). The daily weight gain by Washera sheep in the current study is comparable with the gain by Awassi x Menz crossbred sheep (101.4 g) supplemented with a similar amount of 500 g concentrate day⁻¹ (Solomon *et al.*, 2006).

Table 1. Performance of Washera sheep supplemented with different feed levels of concentrate mix

Trait	R ²	CV (%)	Feeding level (g head ⁻¹ day ⁻¹)					
			0	300	400	500	600	700
INWT*	0.60	14.8	20.5(0.98) ^{ae}	20.7(0.98) ^a	21.2(0.98) ^a	20.0(1.04) ^a	21.2(1.04) ^a	22.4(1.04) ^a
WT93	0.90	4.7	24.9(0.45) ^a	29.1(0.45) ^b	30.7(0.45) ^c	32.0(0.48) ^d	32.8(0.48) ^d	32.9(0.49) ^d
WT121	0.88	5.9	24.4(0.57) ^a	29.2(0.57) ^b	31.0(0.57) ^c	32.9(0.61) ^d	33.8(0.61) ^d	34.7(0.62) ^d
ADG 93	0.79	17.1	38.0(5.3) ^a	88.0(5.3) ^b	101.0(5.30) ^b	119.0(5.60) ^c	126.0(5.60) ^c	126.0(5.60) ^c
ADG121	0.77	17.8	34.0(5.1) ^a	74.0(5.1) ^b	86.0(5.10) ^b	104.0(5.40) ^c	112.0(5.40) ^c	113.0(5.40) ^c
BC	0.67	18.1	1.2(0.13) ^a	1.9(0.12) ^b	1.9(0.12) ^b	2.4(0.13) ^c	2.6(0.13) ^c	2.9(0.13) ^c

*INWT = Initial live weight, WT93 and WT121 = Live weight at 93 and 121 days of feeding and ADG93 and ADG 121 = Average daily gain at 93 and 121 days of feeding. ^eMeans within the same row followed by different letters are different at $p < 0.05$. Numbers in parenthesis are standard errors.

Carcass weight and characteristics

Results indicated that generally, supplementation resulted in increased carcass weight, dressing percentage, fat thickness and rib eye muscle area with increasing level of concentrate supplementation (Table 2). However, trends were not consistent with weight gains regarding feeding levels as carcass weights are expected to correlate well with body weights. This could be due to differences between animals in the different groups in non-carcass components (such as skin and lower leg part) and gut fill. On average the supplemented groups produced 15.7 kg of carcass as compared to 10.6 kg for the control group. Supplementation of 500 g concentrate gave a carcass weight of 15.6 kg with a dressing percentage of 48.5%. Washera sheep appeared to be more efficient in carcass production with dressing percentage of 47.8 to 51.5% in this study as compared to Menz sheep with a dressing percentage of 37 to 47% (Abebe *et al.*, 2006) under different similar levels of concentrate supplementation and slaughter age. The current results are comparable with findings on different fat-tailed Turkey sheep breeds with dressing percentage of 43.1% to 50.6% (Esenbuga *et al.*, 2001) and Moroccan Sardi and D'man sheep breeds with dressing percentage of 46.9% to 47.1% (Boujenane *et al.*, 2003). However, Washera sheep seemed to be less efficient in carcass production compared to specialized European meat breeds with dressing percentage of 52 to 59% (Perez *et al.*, 2002). However, these differences in efficiency could be due to differences in feed type and feeding level.

Table 2. Least square mean (standard error) of carcass characteristics and retail cuts of Washera sheep supplemented different feed levels of concentrate.

Trait	R ²	CV (%)	Feed level (g head ⁻¹ day ⁻¹)					
			0	300	400	500	600	700
Carcass (kg)	0.94	5.22	10.6(0.35) ^{af}	13.5(0.35) ^b	14.7(0.35) ^c	15.6(0.35) ^c	16.9(0.32) ^d	17.6(0.75) ^d
DP (%)	0.60	4.96	44.2(1.08) ^a	47.8(1.08) ^b	48.6(1.08) ^{b,c}	48.5(1.08) ^{b,c}	51.5(1.22) ^c	51.0(1.09) ^{b,c}
Shoulder (kg)	0.93	4.99	3.6(0.10) ^a	4.1(0.10) ^b	4.4(0.10) ^b	4.7(0.10) ^c	4.9(0.10) ^d	5.0(0.10) ^d
Rib (kg)	0.82	8.73	2.0(0.11) ^a	2.6(0.11) ^b	2.6(0.11) ^b	3.0(0.11) ^{c,d}	2.9(0.10) ^{b,c}	3.2(0.10) ^d
Loin (kg)	0.70	12.8	1.7(0.12) ^a	1.9(0.12) ^{a,b}	2.2(0.12) ^{b,c}	2.3(0.12) ^{c,d}	2.4(0.11) ^d	2.5(0.13) ^d
Leg (kg)	0.83	8.33	2.6(0.12) ^a	3.0(0.12) ^b	3.3(0.12) ^{b,c}	3.5(0.12) ^{c,d}	3.8(0.11) ^d	3.7(0.13) ^d
Tail (kg)	0.77	23.6	0.6(0.19) ^a	1.6(0.19) ^b	1.8(0.19) ^b	1.8(0.19) ^b	2.4(0.17) ^c	2.6(0.19) ^c
FT (mm)	0.69	27.2	3.6(0.94) ^a	5.8(1.05) ^{a,b}	6.3(1.05) ^{a,b}	8.6(1.05) ^{b,c}	10.9(0.94) ^c	10.6(0.94) ^c
REM cm ²	0.69	10.1	10.9(0.56) ^a	10.9(0.64) ^a	11.6(0.64) ^{a,c}	14.0(0.78) ^b	14.2(0.57) ^b	12.9(0.63) ^{b,c}

DP = Dressing percentage, FT = Fat thickness, REM = Rib eye muscle. ^fMeans within the same row followed by different letters are different at $p < 0.05$.

Table 3 presents the proportion of the different commercial cuts as percentage of the total carcass. Leg and shoulder proportion of the supplemented groups was significantly ($p < 0.05$) lower than the non-supplemented group. In contrast, tail proportion of in the supplemented groups was significantly ($p < 0.05$) higher than in the non-supplemented group. The leg part represented 21.1 to 24.6 % of the total carcass in Washera sheep in this study, which is comparable with different fat-tailed breeds of Turkey (Esenbuga *et al.*, 2001), but lower than reported for the meat breeds of European and crosses of fat-tailed and thin-tailed breeds of Iran with leg proportion of 28 to 35% (Archimede *et al.*, 2008; Titi *et al.*, 2007; Kashan *et al.*, 2005; Pena *et al.*, 2005; Perez *et al.*, 2002). Proportions of leg and shoulder cuts represent an important character of meat production potential of specialized meat breeds. The current results suggest that Washera sheep tends to expend proportionally much energy in fat deposition in the tail region under high supplementation. Given the higher tail proportion in the supplemented group compared to the non-supplemented group in the current study which is comparable with other fat-tailed breeds but lower than the thin-tailed European breeds as discussed above, it can be hypothesized that fat-tailed sheep tend to deposit fat in the tail rather than the leg/shoulder region under high level of supplementation. This seems waste of energy (although large fat tail fetches higher price in local markets). Selection against fat tail or crossbreeding or tail docking of feedlot animals may be considered to further improve the meat production potential of Washera sheep depending on the target market.

Economics analysis

Results of the economic analysis of Washera sheep fattening are presented in Table 4. Treatment 4 (grazing + 500g concentrate mix) gave the highest net return and marginal rate of return to investment in both 93 and 121 days of feeding. Feeding for 93 was found to be more economical than feeding for a prolonged period of 121 days.

Table 3. Least square mean (standard error) of proportion of different commercial cuts.

Trait	R ²	CV (%)	Feed level					
			0	300	400	500	600	700
Tail (%)	0.51	21.00	6.3(0.01) ^{aE}	11.6(0.01) ^b	12.3(0.11) ^b	11.6(0.11) ^b	14.2(0.01) ^b	14.4(0.11) ^b
Shoulder (%)	0.65	4.35	33.6(0.01) ^a	30.2(0.01) ^b	29.6(0.01) ^{b,c}	29.8(0.01) ^{b,c}	29.2(0.01) ^{b,c}	28.4(0.01) ^c
Rib (%)	0.42	6.27	19.4(0.01) ^a	19.1(0.01) ^{a,b}	17.9(0.01) ^{b,c,d}	19.3(0.01) ^{a,d}	17.0(0.005) ^{c,d}	18.4(0.01) ^{a,d}
Loin (%)	0.21	7.99	15.8(0.01) ^a	14.4(0.01) ^a	14.9(0.01) ^a	14.5(0.01) ^a	14.1(0.005) ^a	14.4(0.01) ^a
Leg (%)	0.38	6.58	24.6(0.01) ^a	21.9(0.01) ^b	22.3(0.01) ^b	22.4(0.01) ^b	22.2(0.01) ^b	21.1(0.01) ^b

^EMeans within the same row followed by different letters are different at $p < 0.05$.

Table 4. Cost benefit analysis of Washera sheep fattening under different level of concentrate supplement and two fattening durations.

Description	Feeding level (g head ⁻¹ day ⁻¹)											
	93 days of feeding						121 days of feeding					
	0	300	400	500	600	700	0	300	400	500	600	700
FWT (kg)	24.9	29.1	30.7	32.0	32.8	32.9	24.4	29.2	31.0	32.9	33.8	34.7
INWT (kg)	20.5	20.7	21.2	20.0	21.2	22.4	20.5	20.7	21.2	20.0	21.2	22.4
TWG (kg)	4.4	8.4	9.5	12.0	11.6	10.5	3.9	8.5	9.8	12.9	12.6	12.3
TCG (kg)	1.9	4.1	4.5	5.8	5.6	5.1	0.0	3.7	4.7	6.1	6.1	5.9
CSP (Birr kg ⁻¹)	45.0	50.0	50.0	50.0	50.0	50.0	45.0	50.0	50.0	50.0	50.0	50.0
GR (Birr head ⁻¹)	86.1	202.6	223.3	291.1	278.4	254.8	0.0	184.9	236.4	303.2	305.6	295.2
FC (Birr head ⁻¹)	0.0	83.7	111.6	139.5	167.4	195.3	0.0	108.9	145.2	181.5	217.8	254.1
NB (Birr head ⁻¹)	86.1	118.9	111.7	151.6	111.0	59.5	0.0	76.0	91.2	121.7	87.8	41.1
MRR (%)		39.2	-25.8	142.9	-145.4	-184.5	30.5	69.8	41.9	84.1	-93.4	-128.7

FWT = Final weight, INWT = Initial weight, TWG = Total weight gain, TCG = Total carcass gain, CSP = Carcass sell price, GR = Gross return, FC = Feed cost, NB = Net benefit, MRR = Marginal rate of return.

Sensitivity analysis (Table 5) showed that profitability of the current fattening practice holds under varying input and output prices of up to 20% variation. However, the marginal rates of return to investment decline from 119.7% when the expectation for input price increase and output price decrease is 5% to 61.9% when the expected price variations are 20%.

Table 5. Sensitivity analysis of Washera sheep fattening based on concentrate supplements for a fattening duration of 93 days.

Description	Feed level (g head ⁻¹ day ⁻¹)					
	0	300	400	500	600	700
+ 5% fattening cost (ETB head ⁻¹)	0.0	87.9	117.2	146.5	175.8	205.1
-5% selling Price (ETB kg ⁻¹)	42.8	47.5	47.5	47.5	47.5	47.5
Gross return (ETB head ⁻¹)	81.8	192.5	212.1	276.5	264.5	242.1
Net benefit (ETB head ⁻¹)	81.8	104.6	95.0	130.0	88.7	37.0
MRR		25.9	-32.9	119.7	-141.1	-176.4
+ 10% fattening cost (ETB head ⁻¹)	0.0	92.1	122.8	153.5	184.1	214.8
-10% selling Price (ETB kg ⁻¹)	40.5	45.0	45.0	45.0	45.0	45.0
Gross benefit (ETB head ⁻¹)	77.5	182.3	201.0	262.0	250.6	229.4
Net benefit (ETB head ⁻¹)	77.5	90.3	78.2	108.5	66.4	14.5
MRR		13.9	-39.3	98.7	-137.1	-169.1
+ 20% fattening cost (ETB head ⁻¹)	0.0	100.4	133.9	167.4	200.9	234.4
-20% selling Price (ETB kg ⁻¹)	36.0	40.0	40.0	40.0	40.0	40.0
Gross benefit (ETB head ⁻¹)	68.9	162.1	178.6	232.8	222.7	203.9
Net benefit (ETB head ⁻¹)	68.9	61.6	44.7	65.4	21.8	-30.5
MRR		-7.2	-50.6	61.9	-130.3	-156.3

MRR = Marginal rate of return.

Conclusion and Recommendations

Feedlot performance of Washera sheep is higher than some other local breeds studied and is comparable with Awassi X Menz crossbred sheep. Supplementation of 500 g day⁻¹ concentrate feed for 93 days would be both biologically and economically the optimum level for feedlot operation. Further research could focus on diverting the energy expenditure in fat deposition in the tail region to the leg and shoulder region. Ration

formulation based on locally available forage and/or cheaper feed resources to replace the concentrate feed recommended here could result in a more profitable feedlot operation. Demonstration to Washera sheep farmers and commercial feedlot operators is recommended in order to promote these feeding technologies.

Acknowledgements

The authors would like to acknowledge the staffs of Animal Science Department at Andassa Livestock Research Center and Debre Birhan Agricultural research Center who participated in animal handling, data collection and recording.

References

- Abebe Mokoya, Dereje Tadesse, Sisay Lemma, Tesfaye Getachew and Solomon Gizaw. 2006. Evaluation of the potential of oat grain and forage legume mixtures for fattening Menz sheep. In proceedings of the first annual regional conference of completed livestock research activities, 14 to 17 August 2006. Amhara regional Agricultural Research institute (ARARI), Bahir Dar, Ethiopia. Pp 1-6.
- Archimède, H., Pellonde, P., Despois, P., and Etienne, A.T.G. 2008. Growth performances and carcass traits of Ovin Martinik lambs fed various ratios of tropical forage to concentrate under intensive conditions. *Small Rumin. Res.* 75: 162–170.
- Boujenane, I., Roudies, N., Benmira, A., El Idrissi, Z., and Ei Aouni, M. 2003. On-station assessment of performance of the DS synthetic and parental sheep breeds, D'man and Sardi. *Small Rumin. Res.* 49: 125-133.
- Esenbuga, N., Yanar, M., and Dayioglu, H. 2001. Physical, chemical and organoleptic properties of ram lamb carcasses from four fat-tailed genotypes. *Small Rumin. Res.* 39: 99-105.
- Kashan, N.E.J., Manafi Azar, G.H., Afzalzadeh, A., and Salehi, A. 2005. Growth performance and carcass quality of fattening lambs from fat-tailed and tailed sheep breeds. *Small Rumin. Res.* 60: 267-271.

- Mengiste Taye, Girma Abebe, Solomon Gizaw, Sisay lemma, Abebe Mekoya, and Markos Tibbo. 2009. Growth performance of washera sheep under smallholder management system Ethiopia. *Trop. Anim. Health Prod.*, DOI 10.1007/s11250-009-9473-x.
- Pena, F., Cano, T., Domenech, V., Alcalde, M.J., Martos, J., Garc'ia-Martinez, A., Herrera, M., and Rodero, E. 2005. Influence of sex, slaughter weight and carcass weight on "non-carcass" and carcass quality in segurena lambs. *Small Rumin. Res.* 60: 247-254.
- Perez, P., Maino, M., Tomic, G., Mardones, E., and Pokniak, J. 2002. Carcass characteristics and meat quality of Suffolk Down Suckling lambs. *Small Rumin. Res.* 40: 233-240.
- SAS (Statistical Analysis System). 2003. SAS for windows, Release 9.1. SAS Institute, Inc., Cary, NC, USA.
- Sisay Lemma. 2009. Phenotypic characterization of indigenous sheep type in the Amhara National Regional State of Ethiopia. M.Sc. Thesis. Haramaya University, Ethiopia, 91p.
- Solomon Gizaw, Tesfaye Getachew, Sisay Lemma, Dereje Tadesse and Abebe Mekoya. 2006. Study on the response to improved feeding of Menz sheep selected high yearling weight. In proceedings of the first annual regional conference of completed livestock research activities, 14 to 17 August 2006. Amhara regional Agricultural Research institute (ARARI), Bahir Dar, Ethiopia. Pp 7-13.
- Solomon Gizaw, Komen, H., Hanotte, O., van Arendonk, J.A.M. 2008. Indigenous sheep resources of Ethiopia: types, production systems and farmers preferences. *Animal Genetic Resources Information* 43:25-40.
- Titi, H.H., Dmour, R.O., Abdullah, A.Y. 2008. Growth performance and carcass characteristics of Awassi lambs and Shami goat kids fed yeast culture in their finishing diet, *Animal Feed Science and Technology* 142: 33-43.



SOIL AND WATER MANAGEMENT

Double cropping and supplementary irrigation potential of harvested drainage water on Vertisols at Enewari district in North Shewa

Tegenu Ashagrie^{1‡}, Adamu Molla¹ and Gizaw Desta²

[‡]Email: tegenu@gmail.com

¹Debre Birhan Agricultural Research Centre, P.O.Box 112, Debre Birhan, Ethiopia

²Amhara Region Agricultural Research Institute, P.O.Box 527, Bahir Dar

Abstract

It is common to get high surface runoff from drained Vertisols in rainfall seasons. There is a great move in Ethiopia towards harvesting and using this runoff for double cropping in every Vertisols without assessing their practical potentials. In this experiment, runoff water drained from wheat field growing on broad bed and furrows (BBF) in 'meher' season was collected in a trapezoidal water harvesting structure. Water balance of the pond and soil erosion losses from the runoff-areas of wheat field was estimated. The potential of collected drained water was assessed for supplementary irrigation of wheat and lentil arranged in Randomized Complete Block design replicated four times. Monitoring of seasonal drainage water balance showed that there was excess water that can be harvested for further use, but storing the water for double cropping or supplemental irrigation was found difficult because of evaporation and seepage losses. Seepage and evaporation losses were enhanced by increased surface area of the structure which was done to compensate for the shallow depth of the pond limited by the depth of soil in the area. As a result, the stored water in the pond was empty on November 29 (first year) and on November 12 (second year). Hence, the study proved runoff collected in such scenarios of the study area cannot support either full (for double cropping) or supplementary irrigation. Based on the findings, the potential of reuse of drained water was hindered due to the environmental losses, as a potential option shallow to deep ground water sources were considered in the study area.

Keywords: Double cropping, drainage water, supplemental irrigation, water harvesting.

Introduction

Since agriculture in Ethiopia is mainly dependant on rainfall, farmers usually wait with anxiety for its timely onset. But, the rain may not usually start at the right time and the unpredicted rainfall may be so heavy that the runoffs produced erode the most fertile land. Annually 112,450 million m³ runoff water is lost into rivers from 12 highland watersheds in

Ethiopia (MWR, 1998). On the other hand, the excess rain causes water logging on heavy clay soils.

Regardless of the huge coverage of Vertisols in the Ethiopian highlands, 7.6 million ha, the productivity of these soils is below their potential mainly due to water logging in the main rain fall season. In the main rainy season, sowing usually starts late and continues to the end so as to grow on the residual soil moisture (Astatke *et al.*, 1991), as a result crop productivity is low. In the Ethiopian highlands, a very high percentage of the land area is drained by some form of indigenous artificial drainage networks in addition to the natural streams and channels. These indigenous drainage practices take many different forms such as broad bed and furrows (BBF), ridge and furrows (RF), and simple open ditches in the moderate to flat slope lands on Vertisols. The primary aim of the drainage is to reduce the level of excess soil-water and improve conditions for cultivation.

Enewari plane, where this study was conducted, is the Vertisols areas having water logging problem. Farmers in this area practice BBF to avoid water logging and improve crop yield. The work of Jutzi *et al.* (1986) also showed that the construction of BBF aids in draining excess water and improves productivity of Vertisols. It has also been suggested that if drained water can be harvested in ponds, there can be various cropping options to utilize the entire growing period. The early sowing of main season crops, such as wheat, could allow an early harvest thereby making the second crop possible. Harvested water can be used to irrigate a second crop during dry season (Astatke *et al.*, 1986). Experiences also showed that at the end of the rainy season the surface layer of the highland Vertisols is frequently quite dry while there is plenty of available soil moisture in the deeper soil layers. This seriously impairs the possibility of crop sowing in the post-rainy season; if sown in such scenarios, the plant stands become poor (Astatke and Saleem, 1998).

Selamyihun (2003) showed that tef-based cropping system of highland Vertisols transformed 23-41% of the seasonal rainfall (July-September) into runoff, which is equivalent to 102-307 mm runoff water per hectare annually. This amount of runoff water would be more than enough to raise a second crop on one hectare of land in the post rainy

season (Kamara and Haque, 1988). This suggests that water harvesting from the Vertisol drainage system can be promoted by harmonizing the local system with small farm ponds. Wheat and lentil are the major crops being produced on separate fields of Vertisols at Enewari. Ample amount of drainable water has been wasted unused for supplementary irrigation for crops grown under rainfed condition or to support double cropping system. It is time to reuse the drainage water for double cropping of wheat with lentil in such a way that wheat is to be grown under rainfed condition as usual whereas lentil is to be grown following the harvest of wheat under full irrigation. However, the amount of water required for lentil production under full irrigation condition must be determined to estimate whether the amount of drainable water collected and stored in shallow ponds could be enough to support this production system.

Therefore, this study was conducted with the objectives of estimating drainage runoff water and associated soil loss from BBF based crop land, and evaluating the potential of trapezoidal storage structure to store and conserve enough water for double cropping and supplementary irrigation so as to improve crop productivity of the area.

Materials and methods

The study area

The experiment was conducted in the District of Moretina Jiru at Enewari research testing site, North Shewa zone of Amhara national regional state. Geographically, Enewari testing site is located at 9^o 52' N, 39^o 10' E and an altitude of 2680 m above sea level. The area is characterized by a unimodal rainfall, receiving annual average of 929 mm. The annual average maximum and minimum air temperatures are 21.4 and 9.0 °C, respectively. Vertisols are dominant in the area, hosting production of wheat, teff, faba bean, and lentil whereas chickpea and grass pea have low area coverage.

Pond construction and water balance data collection

A trapezoidal shape of runoff water storage structure having respective top and bottom width of 10 m and 8 m, depth limited to the Vertisols depth (1 meter), and 1:1 side slopes

was constructed when the soil had enough moisture to compact the side walls and bed of the structure. After compaction, the floor and all sides of the pond were plastered with 5 cm thick layer of selected pellic soil and of mud prepared by mixing soil and chopped teff straw during the first year and second year, respectively, to reduce the seepage loss that could be caused by the cracking of the Vertisols. The runoff drained from BBF on a specific delineated area cultivated with wheat was diverted by main channel into the storage structure. A small silt trap of 1 x 0.5 x 0.5 m size was dug at the inlet to the main pond so that debris and suspended sediment along with overland runoff could settle down. Relatively filtered runoff water would enter to the pond.

Daily stored volume of water in the pond was determined by measuring the water depth at different corners of the pond in the morning (8-8:30 am) every day. The average water depth multiplied by wetted area of the pond gives volume of daily stored water in the pond. Runoff amount entering the pond was calculated using the following water balance equation.

$$dRo = Rf + Ro - E - Sp \dots \dots \dots Eq. 1$$

$$Ro = dRo - Rf + E + Sp \dots \dots \dots Eq. 2$$

Where: Ro is Runoff entering the pond, Rf is Rainfall directly falling in the pond, E = Evaporation loss from the pond, Sp = Seepage loss from the pond, and dRo = Change in runoff volume of the pond.

Soil loss from the total experimental area was determined by summing up of the soil deposit in the storage pond and in the silt trap. Amount of soil loss in the stored water was determined by filtering and oven drying the sediment from one litre runoff sample taken from the pond immediately after heavy storms. Multiplying sediment concentration obtained from one litre runoff water sample by the total stored volume of water gave the total suspended sediment loss in the stored runoff water. Soil loss from the silt trap was determined by weighing the deposited sediment directly from the silt trap at regular interval. Daily rainfall was recorded from the nearby rain gauge. At same time daily

evaporation was recorded from standard evaporation pan, assuming there is equal potential evaporation from the pond and pan.

Experiment setup and data analysis

The area delineated for runoff harvesting was sown to wheat during the main rainy season. In the first year, water balance of the pond was computed to evaluate whether the harvested water has the potential to produce the second crop after harvesting wheat. Thus the water balance analysis showed that the stored water was not enough to support double cropping (Figure 1) as the pond was empty before the harvest of the main rainy season crop, wheat. Consequently, the experiment was modified for supplemental irrigation during the second year of the project life. The source of water for the supplemental irrigation was from another non experimental pond so that the water balance data of the experimental pond would not be disturbed.

Based on the modifications, two independent supplemental irrigation experiments were conducted one for wheat and the other for lentil arranged in RCBD with four replications at Enewari testing site in 2006. Bread wheat (HAR 604 variety) and lentil (Var.: Alemaya) were sown on 13 July and 30 August 2006, respectively, using broad-bed and furrows to drain excess soil water. The experimental plot size was 3.6 by 2.6 m for lentil, and 4.8 by 3 m for wheat. The recommended fertilize levels of 87/20 kg N/P ha⁻¹ for wheat and 18/20 kg N/P ha⁻¹ for lentil were applied while other management practices were also done as per the recommendations of the area. The experimental treatments were: T₁ = No supplementary irrigation (control), T₂ = Irrigated at eight days interval starting from 03 October to 24 November for lentil while only one irrigation at 50% booting stage for wheat, T₃ = One irrigation at 50% flowering for lentil while at 50% heading for wheat and T₄ = One irrigation at 50% pod stage for lentil while one irrigation at 50% heading and one irrigation 15 days later at grain filling stage for wheat.

Irrigation was applied to the level that the soil moisture content reaches to field capacity based on the soil moisture level determined to the depth of 40 cm prior to watering. Field capacity and bulk density of the testing site was determined to be 55% by volume and 1.22

g cm⁻³ using field method procedures. Wheat and lentil were harvested on 15 December and 29 December 2006, respectively. Statistical analysis of variance for yield was done using procedure of mixed model of SAS Version 8 of 1999-2000. Of the four treatments, T₃ (one irrigation at 50% flowering) for lentil was excluded in the analysis for its performance was very low due to its poor establishment that was not related to the treatment effect.

Results and discussion

Pond water balance and potential of harvested water for double cropping

Since water balance is highly sensitive to temporal climatic variation, the two years water balance data were analyzed and presented separately. In both cases similar trend of water stored in the pond and loss from it were observed during the monitoring seasons. In the first year, of the total 81 m³ storage capacity of the pond, about 38.18 m³ (47% of the pond storage capacity), 42.26 m³ (52%), and 11.68 m³ water was accounted to direct rainfall, lost by evaporation, and removed from the pond for it was beyond the pond capacity, respectively, during mid July up to end of November. Regardless of the plenty of runoff and rainfall water entering the pond, the pond was totally empty just on November 29/2005 (Figure 1). In a similar case, during the second year, 70.94 m³ (87.60% of the total storage capacity), 59.6 m³, and 46.9 m³ water was from direct rainfall, removed from the pond to avoid overflow, and lost through evaporation, respectively. Again, the pond was empty just on November 12/2006 (Figure 1). Just on the offset of rainfall, nearly between September 15 and 20, there was only 49.59 m³ stored water in the pond. As compared to the first year, significantly higher amount of water was received from direct rainfall and subsequently discharged from the pond in the second year because of comparatively high rainfall.

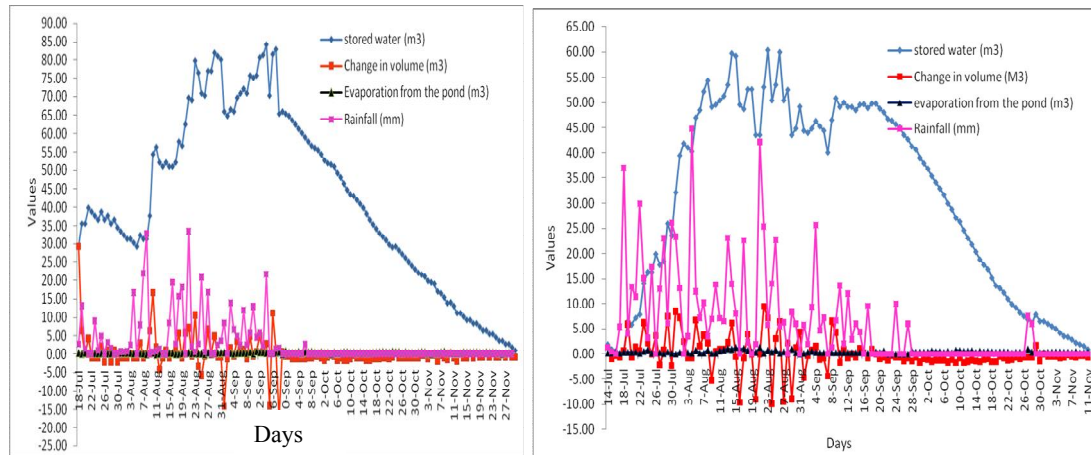

Figure 1. Pond water balance (m³) in 2005 (left) and in 2006 (right).

Generally, results of the two-year study show the same trend. Regardless of large amount of water entering the pond, all the water was lost from the pond before the harvest of the first crop. The amount of runoff water entering the pond from the drained area and from direct rainfall was more than the storage capacity of the pond. This shows that there is very high amount of water for harvesting, but the major challenge was storing it for few months. In Enewari and other similar Vertisol areas where the soil depth is shallow (<1.5 m), the storage capacity of ponds could be increased by increasing pond area rather than the depth. However, this exposes the water for high surface area contact which increases seepage loss to the ground and evaporation loss from the water surface. Hence, the dual loss of evaporation from the top surface of the pond and seepage from the bottom and sides caused early drying of the pond. Similarly, Ahmad (1993) reported that this dual loss in shallow ponds is the main reason why the ponds often dry just at the time when water is most needed to keep crops more productive. In such heavy Vertisols areas of Enewari, the soil dried and cracked immediately after the rainfall ceases. This affected the sidewalls of the pond regardless of the efforts done to compact and line it, and led to high seepage loss. Cracking of the land also increases the water demand for land preparation for the next crop. The suspended and eroded soil sediment channeled through the traditional broad bed furrows was estimated to be 3.67 ton ha⁻¹ per year in the first year and 8.5 ton ha⁻¹ per year second year.

Evaluation of supplementary irrigation

Application of supplementary irrigation at every eight days interval gave significantly ($p < 0.05$) high grain and straw yield of lentil compared to the un-supplemented lentil plot. However, there was no significant yield difference between supplementary irrigation at every eight days and once application at 50% pod stage. Supplementing irrigation at 50% pod stage did not provide significant yield advantage over the un-supplemented one (Table 1). The yield increment obtained from eight days irrigation application was about 38 % for seed yield and 45% for straw yield over the control.

Table 1. Mean yield and supplementary irrigation data for lentil at Enewari, 2006.

Treatment	Grain yield (kg ha ⁻¹)	Straw yield (kg ha ⁻¹)	Amount of irrigation		Irrigation frequency
			Litre plot-1	(m ³ ha ⁻¹)	
Without supplemental irrigation (T ₁)	959 ^{B*}	1445 ^B	0	0	0
Irrigation at every eight days interval (T ₂)	1326 ^A	2095 ^A	1232	1316.24	8 days interval
One irrigation at 50% flowering stage (T ₃)			200	213.68	One irrigation
One irrigation at 50% pod stage (T ₄)	1204 ^{AB}	1574 ^{AB}	224	239.32	One irrigation

*Means in a column followed by the same letters are not significantly different at $P < 0.05$.

All supplementary irrigation treatments did not significantly ($p < 0.05$) improved grain and straw yield of wheat as compared to the control (Table 2). However, the supplemental irrigation application at 50% flowering stage increased the grain yield by 33%; similarly supplemental irrigation application at 50% pod stage increased the straw yield by 28% over the control. The variety HAR604 used in this experiment did not perform well and appeared to be low yielder as compared to its past history when its resistance to yellow rust was intact. Moreover, the recommended sowing date, i.e., early planting immediately after the onset of rainfall, had shown low performance of bread wheat as opposed to the farmers' usual practice, late-sowing (24-30 July). The recent research work also shows that late

sowing gives significantly higher yield of bread wheat on heavy Vertisols areas of Enewari (Adamu Molla, Personal communication).

Table 2. Mean yield and supplementary irrigation data for bread wheat at Enewari in 2006.

Treatment	Grain yield (kg ha ⁻¹)	Straw yield (kg ha ⁻¹)	Amount of irrigation		Irrigation frequency
			water supplemented (Litre plot ⁻¹)	(m ³ ha ⁻¹)	
without supplemental irrigation (T ₁)	1240	2066	0	0	0
One irrigation at 50% booting stage (T ₂)	1511	2517	372	258.33	One irrigation
One irrigation at 80-85% heading stage (T ₃)	1651	2613	360	250	One irrigation
Two irrigations: one at 50% heading and one at grain filling stage (T ₄)	1496	2643	780	541.66	Two irrigations
LSD (5%)	197	355			

The yield increment level obtained from supplementary irrigation seems not attractive as compared to the land lost for pond construction and the laborious irrigation practice. As the clay soil depth was only 1.3 m on the testing site (it was also less than 1.5 m in most of the sampled farmers' fields), it was only possible to prepare a pond of 10 m wide at the top and 8 m wide at the bottom having the depth of 1 m that was able to store 81 m³ of water. If we consider supplementary irrigation every eight days interval for lentil, 81 m³ of the stored water (with the assumption of no seepage and evaporation loss) can only irrigate about 615 m² of lentil field. This is discouraging compared to the yield results obtained without supplementary irrigation (Million, 1994). It is also more challenging when we realize that the pond had only about 50 m³ of water in the beginning of October at which the first supplementary irrigation was about to start. Again, due to seepage and evaporation loss, the pond became empty on the last week of November, at which only about half the supplementary irrigation water requirement could be met. From the wheat yield data, it is implied that no significant advantage of supplementary irrigation was obtained for early sown wheat. This needs further investigation to see whether late sown wheat needs

supplementary irrigation. Therefore, under the present experimental condition when the harvest of first crop is beyond November and December, potential of double cropping as well as supplementary irrigation of field crops using runoff water from Vertisols drainage systems is difficult. Runoff stored in ponds is not enough to satisfy the water demand for both land preparation and growing crops starting from late November at which soil cracks are too many. Under such scenarios, both supplementary irrigation and double cropping needs sufficient water sources like deep wells to guarantee continuous water supply during the application period in the dry season.

Ground water assessment

Besides the potential evaluation of water harvesting systems on Vertisols, assessment of ground water potential was also one of the activities of the study. Around Enewari, many farmers have practiced shallow hand dug wells for domestic water consumption. Stored water depths were measured in May at which maximum ground water depletion is usually expected low (Table 3).

Table 3. Assessment results of farmers' hand dug wells in Enewari areas in 2006.

Well #	Number of users	Depth of well	Stored	Total well
		without water (m)	water depth (m)	
1	Three villages for livestock	2.9	0.6	3.5
2	Three villages for drinking	2.33	0.5	2.83
3	8-10 household (HH) for drinking	3.9	0.4	4.3
4	2-3 HH for drinking	3.56	0.4	3.96
5	6-8 HH for drinking and onion growing	2.6	0.8	3.4
6	1 HH for drinking	2.1	0.25	2.35
7	10-12 HH for drinking and livestock	5.25	1	6.25
8	10-12 HH drinking + livestock	1.95	1	2.95
9	Unknown HH	5	1.27	6.27
10	Unknown HH	5.4	1	6.4

Despite the high domestic consumption during the assessment time and very shallow depth, most wells had good water potential. In addition to the surveyed hand dug wells, an

observation made on 3.2 m depth hand dug well at Bollo village in Enewari had a discharge rate of 0.26 l sec^{-1} , indicating a promising potential if properly utilized and managed. In general, the assessment of hand dug wells indicates there is high potential of deep wells as an alternative in the study area.

Conclusion and Recommendations

Most of the soil depth of Vertisols at Enewari was less than 1.5 m. Consequently, more land is required to increase the surface area of the pond as a compensation for reduced soil depth, which affects the water storage and losses from the pond. First, the shallow farm pond has high surface area in relation to its volume and hence enhances excessive evaporation. Second, the increased surface area contact increased the probability of soil cracking that resulted in high seepage loss. The dual losses of evaporation and seepage are the main causes why the ponds often go dry just at the time when water is most needed. Hence, though there is no problem of runoff water for harvesting, storing the water for later use is challenging because of the mentioned losses. Runoff collected in such practices cannot support supplementary irrigation or even cannot satisfy the wide and deep cracks of Vertisols occurred in November let alone supporting double cropping of field crops. Therefore, it is better to think of deep wells that can continuously supply water for double cropping or supplementary irrigation on Vertisols while runoff collection ponds can serve in recharging ground water so as to keep deep wells as sustainable source for irrigation water.

References

- Abiye Astatke and Saleem, M.A. 1998. Effect of different cropping options on plant available water of surface drained Vertisols in the Ethiopian highlands. *Agricultural Water Management* 36: 111-120.
- Abiye Astatke, Airaksinen, H., and Saleem, M.A. 1991. Supplementary irrigation for sequential cropping in the Ethiopian highland Vertisols using broadbed and furrow land management system. *Agricultural Water Management* 20: 173-184.

- Abiye Astatke, Bunning, S., and Anderson, F. 1986. Pond construction with animal power in the Ethiopian highlands: A manual ILCA, Addis Ababa, Ethiopia, 38 pp.
- Ahmad, S. 1993. Integrated agricultural production and resource management systems. APARMS Handbook, Pakistan Agricultural Research Council and FAO, 48 pp.
- Jutzi, S.C. and Mesfin Abebe. 1986. Improved agriculture utilization of Vertisols in Ethiopian highlands. An inter-institutional approach to research and development. Paper presented at IBSRAM Network Conference in Africa on Improved Vertisol Management, 1-6 December 1986, Nairobi, Kenya.
- Kamara, C.S. and Haque, I. 1988. Soil moisture storage along a top sequence in Ethiopian Vertisols. In: S.C. Jutzi, I. Haque, J. McIntire and J.E.S. Stares (eds). Management of Vertisols in Sub-Saharan Africa. Proceedings of a conference held at ILCA, 31 August-4 September 1987, Addis Ababa, Ethiopia.
- MWR (Ministry of Water Resources). 1998. Country-wide water resources master plan. Addis Ababa, Ethiopia.
- Selamyihun Kidanu. 2003. Water harvesting predictions for small farm ponds in Ethiopian highland Vertisols. Ethiopian Journal of Natural Resources (EJNR), Vol. 5 (2). Ethiopian Society of Soil Science, Addis Ababa, Ethiopia

Evaluation of double cropping and supplementary irrigation of chickpea using drainage water on Vertisols at Dembia district in North Gondar

Yirga Alemu[‡] and Hanibal Lemma

[‡]Email: yirgale@yahoo.com

Gondar Agricultural Research Centre, P.O.Box 1337, Gondar, Ethiopia.

Abstract

An experiment was carried out in 2006 and 2008 to evaluate double cropping and supplementary irrigation of chickpea using harvested drainage water on pellic Vertisols at Kola Diba research station in Dembia district. The study was aimed to investigate the effect of time of supplementary irrigation on the grain yield and supplementary water productivity of chickpea after the harvest of barley produced in the main season. Six supplemental water application periods (2 mm before planting and 11 mm at flowering; 13 mm at vegetative stage; 13 mm at flowering; 13 mm at pod filling stage; 6.5 mm at vegetative stage and 6.5 mm early pod filling; and without supplemental irrigation (control)) were evaluated in RCDB with three replications. Treatments received the same amount of water (13 mm). Result showed that applying 13 mm at vegetative stage, applying 2 mm before planting and 11mm at flowering stage, and applying 6.5 mm at vegetative stage and 6.5 mm at early pod filling stage gave significantly higher yield and water productivity compared to the control. Supplementing chickpea once at vegetative stage (one month after planting), when the chickpea forms branches, gave the highest yield of 1136 kg ha⁻¹. From the economical point of view, frequent irrigation however requires huge labour and time hence irrigating once at vegetative stage had paramount importance. It is concluded that supplementary irrigation particularly at time of planting and/or vegetative stage is recommended on Vertisols in Dembia plain to improve the productivity of chickpea under residual rainfed production system.

Keywords: Chickpea, supplementary irrigation, water harvesting, Vertisols.

Introduction

Chickpea (*Cicer arietinum L.*) meets its high water requirement from residual soil moisture in deep soil, which have been properly restored, with available soil moisture during the preceding rainy season. Chickpea is capable of drawing water from depths greater than 150 cm, but a major proportion of total extractable water comes from the top 60 cm of the soil profile that have the main concentration of active roots. Although chickpea is considered to

be better adapted to low moisture supply condition than many cool season cereals, Leather (1979) reported that its water requirement is higher than that of wheat. The consumptive use of water (ET) for chickpea depends on the soil moisture supply and the yield level. Singh and Bhushan (1979) reported that ET ranged from 110 to 204 mm to produce seed yield of between 900 and 3000 kg ha⁻¹. Within this range, there was a close correlation ($r = 0.85$) between the amount of water and the yield. Information on optimal scheduling of limited amounts of water to maximize yields is essential if irrigation water is to be used most efficiently. The various crop development stages possess different sensitivities to moisture stress (FAO, 1979; Ghahraman and Sepaskhah, 1997).

Drought tolerance is a desirable characteristic for some crops such as chickpea, which grows mainly on residual moisture. Ethiopia in general and Amhara region in particular has a good potential for chickpea production. One reason for this is presence of large coverage of Vertisols, which is about 10.38% of the total area of the region. The Amhara regional bureau of Agriculture and Rural Development (BoARD) is intending to exploit this untouched resource to its maximum by using different drainage, water harvesting and agronomic technologies. Currently chickpea is highly demanded in the international market. Due to this BoARD is pushing the local farmers to enter into production of quality chickpea so as to use the available market to increase the income source to the poor farmer and generate foreign currency for the country. The purpose of this research was to determine rational irrigation scheduling for chickpea with limited availability of water to obtain optimum yields. Therefore, this experiment was conducted to assess the reuse of drained water and double cropping potential from Vertisols for optimum supplementary irrigation of chickpea.

Materials and methods

Description of the study area

Dembia district is located in North Gondar zone of Amhara National Regional State. The district shares borders with Gondar town and Lay Armachiho in the North, Gondar Zuria in the East, Chilga and Alefa districts in the West and part of Lake Tana in the South. The

agro-ecology of Dembia is traditionally classified as Woina Dega. According to MoARD (1998) Dembia plain is classified as Tepid to cool moist plains. Dembia district characterized by mono-modal rainfall season extends from beginning of June to the mid of September with average annual rainfall of about 1095 mm. On an average, the length of the growing season (LGS) of crops is about 146 days. The mean annual potential evapotranspiration is about 1560 mm. Mean maximum and minimum annual temperatures are 27 °C and 13 °C, respectively and the mean annual temperature is 19 °C.

Experimental setup

The trial was conducted at Koladiba research site during 2006 to 2008. The average rainfall during the growing season, from end of September to the end of January, ranges from approximately 80-180 mm and the mean rainfall is 112 mm. The source of water for supplemental irrigation was drained from the Vertisol plot, using Broad Bed Maker (BBM), planted to barley during the main rainy season. The drainage water was collected in an earthen pond with surface area of 25 m², depth of 1 m, side slope of 2:1 and bottom area of 1 m². The pond has a storage capacity of 10.3 m³. The harvested water was applied to supplement chickpea at different growth stages. Using a measuring can, 13 mm of drained water was applied at different growth stages. The different irrigation regimes were: applying 2 mm before planting and 11 mm at flowering stage, applying 13mm at vegetative stage, applying 13 mm at flowering stage, applying 6.5 mm at vegetative stage and 6.5 mm at early pod filling stage, and the traditional practice that is without supplementary irrigation was used as a control. The experimental design was randomized complete block design with three replications.

The data collected were grain yield of chickpea. The seasonal water use (rainfall and supplemental irrigation) was used to calculate water productivity of crops. The yield data were subjected to statistical analysis using SAS statistical package to assess effects of supplemental irrigation regimes on chickpea production. Whenever the variance analysis reveals significant treatment effect means were separated using LSD test at 5% probability level.

Results and discussion

Results showed that supplementary irrigation had significant effect on the grain yield of chickpea (Table 1). Supplementing chickpea applying 13 mm at vegetative stage, applying 2 mm before planting and 11mm at flowering stage, and applying 6.5 mm at vegetative stage and 6.5 mm at early pod filling stage gave significantly higher yield compared to the control (Table 1). However, since frequent irrigation requires high labour and time, irrigating once at vegetative stage is more economical and recommendable. Farmers, who have access to irrigation water from Megech River, used to irrigate chickpea twice at planting and vegetative stage. Hence, the result of this research, which is irrigating once at vegetative stage, is in a good conformity with farmers practice. Since the heavy clay soil holds adequate residual soil water until beginning of October, supplementary irrigation at planting is not necessary unless the farmers plant late in October and beyond.

Table 1. Effect of supplementary irrigation on the grain yield of chickpea on Vertisols at Dembia combined over years (2006 and 2008).

Treatment	Grain yield (t ha ⁻¹)	Yield increase (%)
Applying 13 mm at vegetative stage	1.14 ^a	183
Applying 2 mm before planting & 11mm at flowering stage	1.02 ^a	155
Applying 6.5 mm at vegetative stage & 6.5 mm at early pod filling stage	1.01 ^a	152
Applying 13 mm at flowering stage	0.82 ^{ab}	104
Applying 13 mm at early pod filling stage	0.94 ^{ab}	134
Without supplementary irrigation (control)	0.40 ^b	
CV (%)	46	

*Significantly different at probability level of 10%.

The combined result showed that there was significance difference in water productivity between treatments (Table 2). The respective rainfall during the chickpea growing season was 176 and 107 mm in 2006 and 2008. The 2008 growing season rainfall was close to the last 20 years mean rainfall of 112 mm. Results showed that similar to the grain yield applying 13 mm at vegetative, applying 2 mm before planting and 11mm at flowering, and

applying 6.5 mm at vegetative and 6.5 mm early pod filling stage gave significantly higher water productivity compared to the control (Table 2).

The soil of the experimental field was deep black clay soil which forms wide cracks during dry season. Hence, irrigating early before the formation of cracks is very essential; otherwise the irrigated water could be lost through the deep and wide cracks. This was observed when irrigation was done late at flowering and pod filling stages. Similar to our result, the research conducted in India indicated that supplementary irrigation early during the vegetative growth stage and early pod filling stage on heavier and deep soils gave an increased yield (Sexenal, 1980). Supplemental irrigation to relieve the crop from moisture stress at critical growth stages has resulted in substantial yield increase in chickpea (Sexenal, 1980). Frequent low volume irrigation, in areas where temperature rise beyond the optimum during the development stage, has an advantage of lowering the soil and crop canopy temperature with favourable effect on nodulation and nitrogen fixation, and crop yield.

Table 2. Effect of supplementary irrigation on water productivity of chickpea on Vertisols at Dembia combined over years (2006 and 2008).

Treatment	Applied irrigation & rainfall water (m ³ ha ⁻¹), 2006	Applied irrigation & rainfall water (m ³ ha ⁻¹), 2008	Average water productivity (kg m ⁻³)
Applying 13 mm at vegetative	1890	1200	0.73 ^A
Applying 2mm before planting and 11mm at flowering	1890	1200	0.71 ^A
Applying 6.5 mm at vegetative and 6.5 mm early pod filling stage	1890	1200	0.66 ^A
Applying 13 mm at flowering stage	1890	1200	0.51 ^{AB}
Applying 13 mm at early pod filling stage	1890	1200	0.62 ^{AB}
Without supplementary irrigation (control)	1760	1070	0.28 ^B
CV (%)			29

*Significantly different at probability level of 10%.

Conclusion and Recommendations

Most farmers in Dembia plain grow chickpea on residual moisture after harvesting early maturing tef, barley or in a fallow land. Generally, they did not supplement irrigation water as they do not have access to irrigation water. However, due to the nature of Vertisols and plain topography draining excess soil water is a must for better rainfed crop production. Harvesting and reusing the drained water for double or supplementary irrigation is, therefore, considered to maximize the potential of Vertisol production.

Chickpea production in Dembia area requires 388 mm of water throughout the growing season. However, the mean rainfall in the growing season is 112 mm. However, both the residual soil water and rainfall could not meet the water requirement of chickpea. Therefore, supplemental irrigation is essential. Supplementary irrigation of chickpea showed significant difference on yield of chickpea compared to the usual un-supplemented chickpea production in the locality. Supplementing chickpea with 13 mm of water once at vegetative stage (nearly one month after planting) gave the highest yield. Hence it is advised that farmers in Dembia should use supplementary irrigation once at vegetative stage for maximum productivity of chickpea. Since we used fixed amount of irrigation it is not possible to show water yield production function, hence further research is required to accurately determine the amount of supplementary irrigation for maximum chickpea production in Dembia.

References

- Leather, J.W. 1979. Water requirement of crops in India, India department of agriculture.
- Sing, G. and Bhushan, L.S. 1979. Water use, water use efficiency and yield of dry land chickpea as influenced by P fertilization and stored water and crop season rainfall. *Agricultural water management* 2:299-305.
- Sexenal, M.C. 1980. Recent advances in chickpea agronomy. Workshop on chickpea improvement, 28 Feb-2 Mar 1979, Hhydrabad, ICRISAT, Patencheru, India.

On-farm evaluation of Vertisol management techniques at Bichena district in East Gojjam

Berihun Dubale^{1‡}, Anteneh Abewa¹, Tadele Amare¹, Menelek Getaneh¹ and Birru Yitafaru²

[‡]Email: berihun2010@gmail.com

¹Adet Agricultural Research Centre, P.O. Box 08, Bahir Dar, Ethiopia

²Amhara Region Agricultural Research Institute, P.O. Box 527, Bahir Dar, Ethiopia

Abstract

In Ethiopia where little land is available for extensive crop production, intensifying production on the already available cultivated land becomes a necessity in order to feed the expanding population. One such way in which this could be achieved is proper management of Vertisols, whose potential has not yet been fully exploited for the main reasons of poor workability and poor drainage. There is tremendous possibility to increase the productivity of these soils through efficient management in combination with appropriate use of fertilizer and improved varieties. This study was undertaken to evaluate selected Vertisol management techniques (broad bed and furrow (BBF), ridge and furrow (RF), surface drainage ditches (SDD) and flat seedbed (FSB)) to select the best technique for scale-up in Northwestern Ethiopia. The trial was conducted in 2006 and 2007 involving two wheat crops (bread wheat and durum wheat). Results showed that the effects of Vertisol management techniques were crop and season dependent. In the 2006 cropping season, bread wheat responded positively to different Vertisol management techniques, though yield differences that warrant statistically significant differences were obtained only for BBF and RF when compared to SDD and FSB. In the 2007 cropping season, yield differences of bread wheat due to differences in methods of seedbed preparation were not significant. The results on durum wheat showed significant differences among drainage techniques for both 2006 and 2007 seasons. Performance of drainage techniques should, therefore, depend on both crop type and season. Durum wheat fields always need drained seed bed regardless of seasonal differences, whereas bread wheat fields should be drained depending upon the severity of water logging anticipated.

Key words: Drainage methods, Vertisols.

Introduction

Vertisols are among the most abundant soil orders in Ethiopia, occupying 12.7 million hectares of land and having extensive area coverage in the central highlands of Ethiopia (Astatke and Mohammed, 2001). They have high natural fertility, high water holding

capacity and responds well to many of the crop requirements. Their abundance along with their good inherent fertility make these soils very important in the sense that they possess great potential for increasing production if properly managed to tackle the problems of water logging and poor workability. Vertisols have long been put into productive use in Ethiopia and the land use system ranges from cereal production (barley, wheat, tef) through pulse production (faba bean, field pea, lentil, chickpea) to extensive grazing (Syers *et al.*, 2001). In the central highlands crops such as tef, barley, wheat, faba bean, field pea, chickpea, lentil, noug (*Guizotia abyssinica*) and linseed are often produced on Vertisols under drained conditions and on relatively better drained sites (Hailu and Asgellel, 1990).

The most widely practiced systems of Vertisol management in the central highlands include the construction of drainage system with the local '*maresha*' of narrow ridges and furrows at sowing called '*shurube*' and shallow drainage furrows at varying distances across the contour to achieve good drainage (Hailu and Asgellel, 1990). Another technique of achieving good drainage practiced by farmers of Enewari area in North Shewa is called '*lebesoshi*' where they use their hands to make broad beds and furrows (BBF) to protect crops from water logging in the rooting zone (Hailu and Asgellel, 1990). In order to relieve women of the painful drudgery making beds and furrows by hand, ILCA developed the low-cost oxen-drawn broad bed and furrow maker (BBM), which has been adopted by some 300 000 peasants in the central highlands (Paulos *et al.*, 2001). At higher elevations of the central highlands exceeding 2400 m a.s.l., soil burning is practiced extensively in which case the clay fractions in the surface horizon bake into sand sized particles facilitating infiltration and improving drainage. Still another technique is the use of residual soil moisture for crop production in the late rainy season called '*amegn*'.

There is ample evidence that substantial increase in crop yield can be achieved on Vertisols if excess surface soil water is drained off and appropriate cropping and soil fertility practice is employed. For instance, research conducted at Sheno and Ginchi in the central highlands of the country indicated that yield of crop can be increased by using improved drainage methods, mainly camber beds 6-8m wide and Nitrogen and Phosphorus fertilizer application (Hailu and Asgellel, 1990). Still another experiment conducted at Sheno to

drain excess soil water by using parallel surface drainage ditches of different spacing (3, 6, 9, 12, and 15 meters) showed that increased mean yields were obtained from spacing of drainage ditches at intervals of 3m and 6m, respectively (Hailu and Asgellel, 1990).

Since Vertisols are known to vary widely in their physical and chemical behaviour, they require specific type of soil and water management strategies suited not only to the climate, but also to the type of farming or natural resource use, the terrain and the prevailing socio-economic conditions (Syers *et al.*, 2001). Several studies have so far been conducted on Vertisols in Ethiopia but have all been carried out in the central highlands and almost little or no study, related to the management techniques that best fit the prevailing physical and socio-economic environment, has been conducted in the Northwestern part of the country despite an appreciably high area coverage of Vertisols in the region. It has been tried to introduce the BBF system; but the uptake of the technology by farmers is found to be very low. This study was, therefore, conducted in order to carry out on-farm evaluation of different Vertisol management techniques that are generally referred to have showed promising performances by different researches.

Materials and methods

The study area

The study site is located in Northwestern Ethiopia in East Gojjam at Bichena district, at about 10.470 N latitude and 38.230 E longitude and at an altitude of 2560 m above sea level. The site receives 1174.1 mm of annual rainfall on uni-modal basis that is distributed uniformly over the growing season (May to October) and peaks in July (Table 1). The physiography of the site is dominated by plains where about 85% of the soils are Vertisols. Major crops grown include tef, chickpea, wheat, and grass pea where tef and wheat are main season crops on relatively drained sites and chickpea and grass pea are crops grown on residual moisture after the main rainy season is over. There is generally low level of arable farming at the site mainly due to Vertisol related management problems.

Table 1. Monthly rainfall data (mm) of study site during the study period.

Month	Year	
	2006	2007
January	0.1	0.0
February	3.0	0.0
March	49.4	31.5
April	76.0	20.4
May	94.0	122.4
June	142.5	171.5
July	410.9	272.5
August	94.4	242.0
September	154.5	144.0
October	6.5	0.0
November	4.5	0.0
December	0.0	0.0
Sum	1035.8	1004.3

Experimental setup

Four Vertisol management techniques (Broad Beds and Furrows (BBF), Ridges and Furrows (RF), Surface Drainage Ditches (SDD), and Flat Seed Beds (FSB)) were evaluated in RCBD with three replications. BBF refers to 80 cm wide beds separated by 30 cm wide furrows, RF refers to 60 cm wide ridges and 30 cm wide furrows, SDD refers to 30 cm wide surface drainage ditches at 3m intervals, FSB refers where no furrow or ditch was constructed. Variety HAR1685 of bread wheat and DZ2023 of durum wheat were used for the study.

Results and discussion

Mean values for nearly all measured agronomic parameters of the first season (2006) showed that there exist significant differences among drainage techniques for both durum and bread wheat varieties. However, in 2007, results showed non-significant differences for bread wheat while the differences were significant for durum wheat.

Bread wheat

In the 2006 cropping season significantly higher grain yields were recorded for BBF and RF with yield advantages of 0.67 and 0.65 tons ha⁻¹ over SDD and 0.74 and 0.72 tons ha⁻¹ over FSB, respectively (Table 2). This could be due to the improved drainage in these beds. A similar study in Delanta Dawunt, North Wello, revealed that BBF with 100 cm bed width gave 51.4% yield advantage over the un-drained plots (Fassil and Eyeburu, 2008).

In the 2007 cropping season significant differences between treatments were not observed (Table 2). This is explained by differences in rainfall amount and distribution observed during the study period (Table 1). In 2006, total annual rainfall amount received was 1035.8 mm with 410.9 mm of which was received in July during which planting took place. As a result, severe water logging that occurred in this month affected seed germination and consequently crop yield. In contrast, 2007 received 1004.3 mm of annual rainfall with 272.5 mm of which was received in July. This is considerably lower (by about 34%) than the preceding season. Therefore, the water logging effect in the second season was not strong enough to bring about treatment differences.

Table 2. Effect of Vertisol management techniques on the grain yield of bread wheat at Bichena in 2006 and 2007.

Treatment	Grain yield (t ha ⁻¹) in 2006	Yield advantage (%)	Grain yield (tons ha ⁻¹) in 2007	Yield advantage (%)
BBF	4.09 ^{a*}	22.46	2.37	---
RF	4.07 ^a	21.86	2.69	---
SDD	3.42 ^b	2.40	3.13	---
FSB	3.34 ^b	---	3.74	---
CV (%)	7.6		17.03	

*Means followed by the same letters are not significantly different at $p \leq 0.05$.

Durum wheat

In the 2006 season all drainage techniques gave significantly higher grain yield over the FSB, but there were no significant differences between them (Table 3). In 2007 significant differences between treatments were observed where BBF and RF gave significantly higher

yields, but were not significantly different from FSB. This explains that durum wheat is more sensitive to water logging than bread wheat.

Table 3. Effect of Vertisol management techniques on the grain yield of durum wheat at Bichena in 2006 and 2007.

Treatment	Grain yield (tons ha ⁻¹) in 2006	Yield advantage (%)	Grain yield (tons ha ⁻¹) in 2007	Yield advantage (%)
BBF	4.57a	27.30	3.80 ^a	40.22
RF	4.65a	29.53	2.66ab	---
SDD	4.38a	22.00	1.54b	---
FSB	3.59b	---	2.71ab	---
CV (%)	9.02		24.61	

**Means followed by the same letters are not significantly different at $p \leq 0.05$.*

Conclusion and Recommendations

In general, in this study, raised beds showed better performance and relatively higher yield than the flat seedbeds. Since crop performance was visually observable from crop stand, farmers also showed appreciation and interest to these management techniques. In 2006, BBF showed 0.74 tons ha⁻¹ and 0.98 tons ha⁻¹ yield advantages over the flat seedbed for bread wheat and durum wheat, respectively. In 2007, BBF gave yield advantage over other methods for durum wheat, even though differences remained non-significant for bread wheat.

BBF was identified to be best Vertisol management technique followed by RF and SDD. However, the response was dependent upon season and crop type. The rainfall in July 2006 was heavier than in 2007. Consequently, water logging was severe in 2006 and both crops responded significantly to drainage methods. However, in 2007 only durum wheat showed significant differences among drainage techniques, which is an indication that both crops are not equally sensitive to water logging. Durum wheat should always be provided with drainage methods regardless of seasonal differences to be more sensitive than bread wheat

to water logging. Drainage requirements are, therefore, dependent upon crop type and the season.

References

- Abiye A. and Mohammed, J. 2001. Low-cost animal-drawn implements for Vertisol management and strategies for land use intensification. In: The Sustainable Management of Vertisols. International Water Management Institute (IWMI), Thailand. Pp. 189-201.
- Fassil Kebede and Eyeburu Bekelle. 2008. Tillage Effect on Soil Moisture Storage and Wheat Yield on the Vertisols of North Central Highlands of Ethiopia. Ethiopian Journal of Environmental Studies and Management Vol.1 No.2 -----pp.
- Hailu Regassa and Asgellil Dibabe. 1990. Properties and management of Vertisols in the Central Zone of Ethiopia. In: The Proceedings of the Second Natural Resources Conservation Conference. 10-13 May 1990. Institute of Agricultural Research (IAR), Addis Ababa, Ethiopia. Pp. 26-33.
- Paulos, D., Asgellil, D., Asfaw, Z., Gezahege, A. and Abebe, K. 2001. Advances in Vertisol management in Ethiopian highlands. Proceedings of The International Symposium on Vertisol Management. 28 November to 1 December 2000. Ethiopian Agricultural Research Organization (EARO), Debre Zeit, Ethiopia.
- Syers, J.K., First, W.T., Peningde, V. and Phibion, N. 2001. The sustainable management of Vertisol. International Water Management Institute (IWMI), Thailand.

Effect of in-situ moisture conservation structures for improving the yield of field crops in moisture stress areas at East Belessa district in North Gondar

Yirga Alemu[‡] and Hanibal Lemma

[‡]Email: yirgale@yahoo.com

Gondar Agricultural Research Centre, P.O. Box 1337, Gondar, Ethiopia.

Abstract

There are different in-situ rainwater harvesting techniques that are used to support the production of field crops, trees and forages in moisture stress areas. Among these practices the efficiency and effectiveness of four in-situ rainwater harvesting techniques namely contour ridges, trapezoidal bunds, contour stone bunds, contour soil bunds and control (without in-situ water harvesting practice) were evaluated for growing chickpea and sorghum. Results showed that there were significant differences among the in-situ moisture conservation practices on the yield of chickpea in the first year (2005). Though there was no significant difference among the in-situ moisture conservation structures, trapezoidal bunds provided 82% yield advantage over the control in chickpea. In 2007, sorghum was planted on previously constructed structures at the beginning of July. In sorghum there was no yield advantage due to trapezoidal bunds. However, contour soil bunds gave the highest (69%) yield advantage over the control in sorghum. Based on soil moisture, grain yield, and cost-benefit analysis it can be concluded that compared to the other structures contour soil bund could conserve more water and provide highest yield. On the other hand, among others, contour ridges provided the highest internal rate of return. Farmers in Belessa area are therefore advised to construct either contour soil bunds, contour ridges or trapezoidal bunds alternatively on their farmlands.

Key words: Dryland, in-situ water harvesting, moisture stress, rainfed cropping.

Introduction

Rainfed agriculture has failed to provide the food requirements for the rapidly increasing population of the country. Failure in the rainfed production is a recurrent phenomenon particularly in the semi-arid areas of Ethiopia. In the semi-arid regions of Ethiopia, the amount of rainfall is usually inadequate and erratic in distribution and variable in nature. Consequently, moisture availability is the most limiting factor for rainfed crop production. In regions where crops are entirely rainfed, reduction of 50% in the seasonal rainfalls, for

example, may result in total crop failure. If, however, the available rain can be concentrated on smaller area, reasonable yields will still be received (Critchley, 1991).

It is believed that substantial increase of crop yield can be achieved through the use of proper soil and water conservation and management practices. Efficient use of available water by plants has also an impact on crop management practices such as the use of fertilizer. In dry areas, the response of crops to fertilizer application is low compared to the areas with optimum soil moisture conditions. Although the reasons are complex, the primary constraint in the semi-arid area is lack of suitable soil moisture management practices used for crop production under relatively low and erratic rainfall conditions (Reddy and Kidane, 1993).

In North Gondar Administrative Zone, due to wide variation in topography and altitude (500-4620 m), there is wider coverage of different agro-ecological zones from *kola* to *wurch* (BoFED, 1999). The majority of the areas have thus experienced shortage of rainfall during the crop growing season, which makes rainfed agriculture more difficult. However, there is now increasing interests in the application of in-situ water harvesting practices in drought prone areas. In the drought prone areas, rainwater harvesting is possible by the application of efficient and suitable in-situ water conservation structures. However, there is little information available about the efficiency and effectiveness of *in-situ* rain water harvesting techniques for field crop production in specific localities. Therefore, the objectives of this study were to evaluate the efficiency of different in-situ soil moisture conservation techniques and also to evaluate the effectiveness of the structures for improving yield of field crops.

Materials and methods

The study area

The study area is located in North Gonder at East Belesa district near Gohala. The experimental site is located at 12^o 25' 28" N latitude and 38^o 05' 36" E longitude with an elevation of 1890 m a.s.l. The area receives annual average rainfall of 630 to 950 mm.

Often the rainfall occurs from the fourth week of June to the end of August. The coincidence of late onset, early cessation and uneven distribution of rainfall has resulted in terminal dry spells, recurrent drought and consequently unreliable rainfed cropping in the area. The maximum and minimum reference evapotranspiration (ET_0) in the area is 5.86 mm per day in March and 2.78 mm per day in August, respectively. The mean daily temperature ranges from 19 °C to 24 °C. The maximum and minimum mean temperature is 29 °C and 14 °C, respectively. The slopes are gentle (below 5%), the topography is even and the soils are suitable for agriculture. Soils were well drained, light to dark brown in color, and with moderate depth. The major crops grown in the area are sorghum and teff.

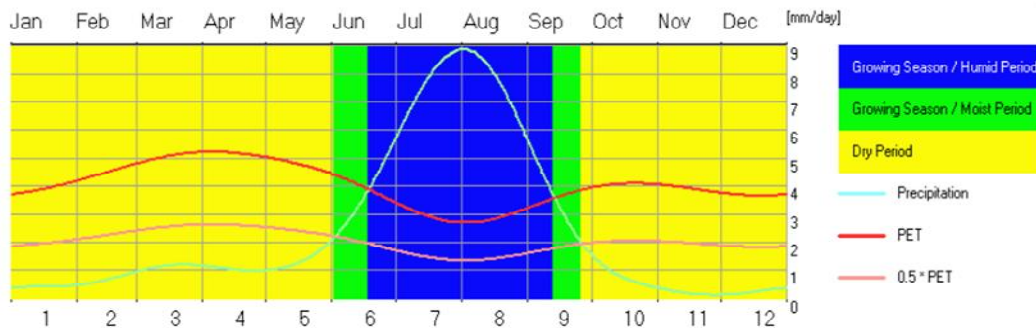

Figure 1. Length of growing season in East Belesa.

Experimental setup

The experiment was conducted from 2005 to 2007. The experimental design was RCB with three replications. Treatments were four in-situ rainwater harvesting techniques (trapezoidal bunds, contour stone bunds, contour soil bunds) and a control (without in-situ water harvesting). The construction and layout of the techniques described in Critchley (1991) was used with some modifications. The dimension of the experimental plot was 17 m x 7 m. Spacing between plots and blocks was 1 m and 1.5 m, respectively. Diversion ditch was constructed at the upper boundary of the plot to prevent the inflow of runoff from upslope area. The structural design of each experimental treatment is described and illustrated as follows.

Contour ridges (T1) are ridges that follow the contour at spacing of 2 meter. Runoff was collected from the uncultivated strip between ridges and stored in furrows just above the ridges. Crops were planted on both sides of the furrow. The system is so simple to construct by hand and can be even less labor intensive than the conventional tillage.

Design specification: Ridge height is 0.20 m, tie height is 0.15 m, spacing of ridges and ties is 2 m and 5 m, respectively, length of ties is 0.75 m.

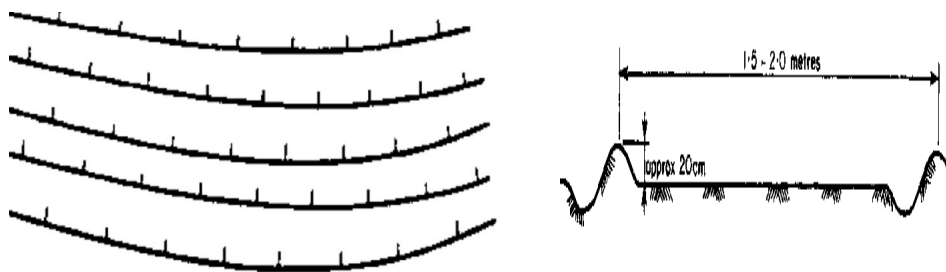

Figure 2. Field layout and cross-sectional view of contour ridges.

Trapezoidal bund (T2) is used to enclose larger areas (up to 1 ha) and to impound large quantities of runoff, which is harvested from an external or long slope catchments. Crops are planted with in the enclosed area.

Design specifications: Length of base bund is 3 m, angle between base and side bunds is 135° , maximum bund height is 0.6 m, minimum bund height is 0.2 m, bund side slopes is 1:1, base width of bund is 1.8 m, top width of bund is 0.6 m.

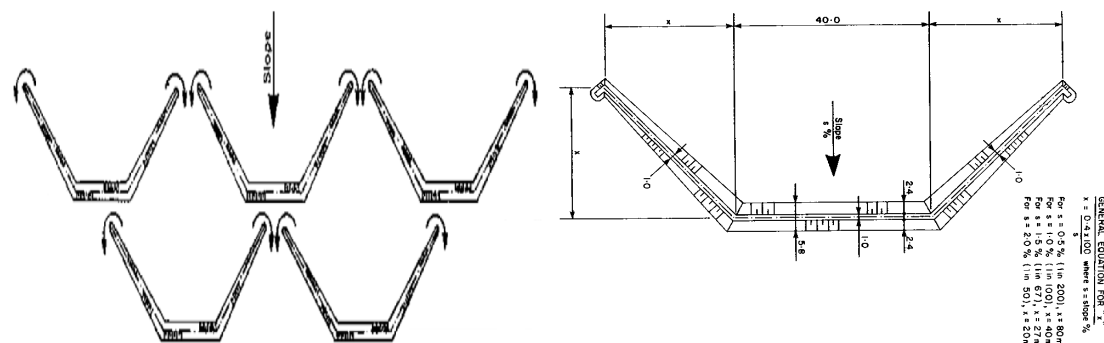

Figure 3. Field layout (top) and typical dimensions (bottom) of trapezoidal bunds.

Contour stone bunds (T3) are used to slow down and filter runoff, thereby increasing infiltration and capturing sediment. The water and sediment harvested lead directly to improve crop performance. This technique is well suited to small scale application on farmer's fields. When an adequate supply of stones is available it can be implemented quickly and cheaply.

Design specifications: Spacing of bunds is 7 m, bund height is 0.25 m, base width is 0.35-0.40 m, shallow trench for foundation is 0.10 m.

Contour soil bunds (T4) are used to hold overland flow of runoff, through the area in the surrounding space of two adjacent bunds.

Design specifications: Spacing of bunds is 7 m, bund height (minimum) is 0.35 m, base width is 0.75 m, spacing of ties is 5 m, length of ties is 2 m.

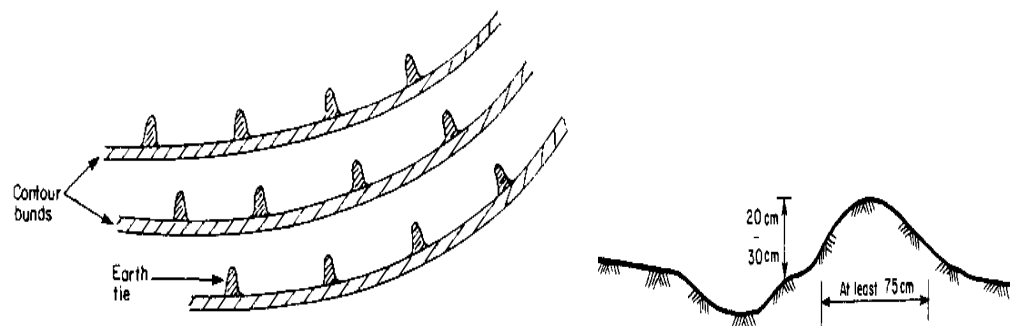

Figure 4: Field layout and cross-sectional view of soil bund.

Without water harvesting (T5) represents the local practice as a control. It is conventional ploughing of the land similar to the farmers' usual practice in the area.

The soil moisture conservation structures were constructed before the beginning of the rain, in May 2005. Once the conservation structures constructed, the field was ploughed and left without planting until the end of August. The test crop, chickpea, was planted at the end of

August using residual moisture conserved by the structures and later harvested in December. In 2007, sorghum was planted on previously constructed structures at the beginning of July and harvested at the beginning of January.

Local varieties of chickpea and sorghum were used as test crops. Fertilizers at the rate of 100 kg Urea and 50 kg DAP were applied equally for all plots for the sorghum crop. The data collected were grain yield of chickpea and sorghum, and moisture content of the soil for each experimental treatment using gravimetric method. Grain yield data was also used to calculate water use efficiency. The data were subjected to statistical analysis using SAS statistical package. Whenever the variance analysis revealed significant differences, means were separated using LSD at 5% probability level.

Composite soil samples were collected all over the experimental fields. Analysis was made following the standard laboratory procedures. Soil moisture characteristics of the site before the set up of the experiment were determined using a computer program developed by Saxton and Rawls (2006) using soil texture and organic matter as input data. Using the software program soil water parameters like field capacity, permanent wilting point, saturation percent, available water, hydraulic conductivity and bulk density were computed and estimated.

Results and discussion

Soil moisture characteristics

Some of the physicochemical properties of the experimental site are presented in Table 1. The soil texture was clay loam. Table 2 shows the estimated values of soil moisture characteristics before the start of the experiment. Rainfall usually ceases at the end of August when sorghum is at grain filling stage at which there is high demand of soil moisture.

Table 1. Soil Physicochemical properties of East Belessa experimental site.

Parameters (Method of analysis)	Unit	Value	
Total nitrogen (Kjeldhal)	%	0.03	
Organic matter (Walkley & Black)	%	1.32	
Available P (Olsen)	ppm	4.84	
CEC (Amm. Acet.)	cmol ⁺ /kg	68.40	
pH H ₂ O (1:2.5)	pH meter	8.60	
Available K (Morgan solution)	ppm	84.00	
Soil texture (Hydrometer method)	Sand	%	40
	Clay	%	38
	Silt	%	22

Table 2. Soil water characteristics of the site before the experiment.

Soil water characteristics	Unit	Value
Permanent wilting point	% weight	15.8
Field capacity	% weight	24.1
Saturation percent	% weight	30.3
Available water	mm/m	120
Saturated hydraulic conductivity	mm/hr	1.90
Matric bulk density	g/cm ³	1.47

Table 3 indicates the soil moisture content by weight measured nearly one month after the end of the rainfall period. The measurement of soil moisture content stored due to the construction of soil moisture conservation practices is used to evaluate the efficiency of the structures to store soil water. The soil moisture content at different soil depths showed that all of the in-situ moisture conservation structures stored soil moisture greater than the permanent wilting point of the soil. The soil moisture content generally increased as the soil depth increased.

There was statistically significant difference in soil moisture content by weight among the in-situ moisture conservation structures. The greater magnitude of soil moisture content was measured on plots treated with contour soil bund, contour ridges and trapezoidal bund in descending order. The plot managed by contour stone bunds and the plot without soil moisture conservation structures retained the lowest soil moisture. Hence, it can be said that

construction of contour stone bunds on farmlands does not have a relative beneficial effect in soil moisture conservation. In general, the results indicated the relative efficiency or soil moisture retention capacity of the structures. Furthermore, this ensures the availability of soil water for subsequent growth and improved production of sorghum which otherwise exposed for terminal drought in the later growing season.

Table 3. Soil moisture content (% weight) 3 months before the harvest of sorghum under different soil moisture conservation techniques in East Belesa.

Structure	Soil moisture content (%) at 15 cm depth	Soil moisture content (%) at 30 cm depth	Soil moisture content (%) from 0-45 cm depth
Contour ridges	25.18 ^{ab*}	31.34 ^{ab}	28.26 ^{ab}
Trapezoidal bund	23.39 ^{ab}	32.00 ^a	27.36 ^{ab}
Contour stone bund	22.09 ^b	27.67 ^b	24.88 ^b
Contour soil bund	27.00 ^a	33.67 ^a	30.34 ^a
Without moisture conservation (Control)	20.83 ^b	27.66 ^b	24.25 ^b
CV (%)	11	8	16

*Means in a column followed by similar letters are not significantly different at $P < 0.05$.

Grain yield of field crops

The grain yield result (Table 4) showed that there was significant difference among the in-situ moisture conservation structures in the yield of chickpea planted at the end of August. According to the result, trapezoidal bunds provided better yield of chickpea than other in-situ moisture conservation structures. Though there was no significant yield difference among the other in-situ moisture conservation structures, the yield of chickpea planted on trapezoidal bund was significantly different from the control plot (500 kg ha⁻¹ yield advantage).

In 2007, there was a positive response of sorghum yield planted at the end of June to the different in-situ moisture conservation structures. The grain yield of sorghum was 1514, 1256, 1089, 1083 and 897 kg ha⁻¹ for plots treated with contour soil bund, contour ridges, trapizoidal bund, contour stone bund and control, respectively. Eventhough there was no

significant yield difference among the structures, contour soil bund provided significant yield difference than the control plot by about 600 kg ha⁻¹ yield advantage. There was symptoms of yellow leaf color and stunted growth of sorghum beneath the trapezoidal bund which is an indication of waterlogging. This most likely led to the relative reduction of sorghum yield planted on trapezoidal bunds.

Table 4. Effect of in-situ moisture conservation structures on yield of chickpea and sorghum.

In-situ moisture conservation structures	Chickpea (2005)		Sorghum (2007)	
	Grain yield (kg ha ⁻¹)	Yield advantage (%)	Grain yield (kg ha ⁻¹)	Yield advantage (%)
Contour Soil Bund	938 ^{ab*}	47	1514 ^a	69
Contour Ridges	992 ^{ab}	55	1256 ^{ab}	40
Trapezoidal Bund	1161 ^a	82	1089 ^{ab}	21
Contour Stone Bund	835 ^{ab}	31	1083 ^{ab}	21
Without moisture conservation (Control)	638 ^b	-	897 ^b	-
CV (%)	26		28	

**Means in a column followed by similar letters are not significantly different at P<0.05.*

Linear regression equation was fitted on sorghum yield and terminal soil moisture content taken at the beginning of October to see the relationship. The equation showed that there was strong relationship between terminal soil moisture content and yield of sorghum with high coefficient of determination, $R^2 = 0.8$ (Figure 5). The soil moisture content and yield relationship has proven that soil moisture availability during the late growing season is the most limiting factor explaining 80% of the yield variation for sorghum. The relationship has also indicated that through understanding the soil moisture retention and storage behaviour of conservation structures, one can reasonably forecast the yield of rainfed crops.

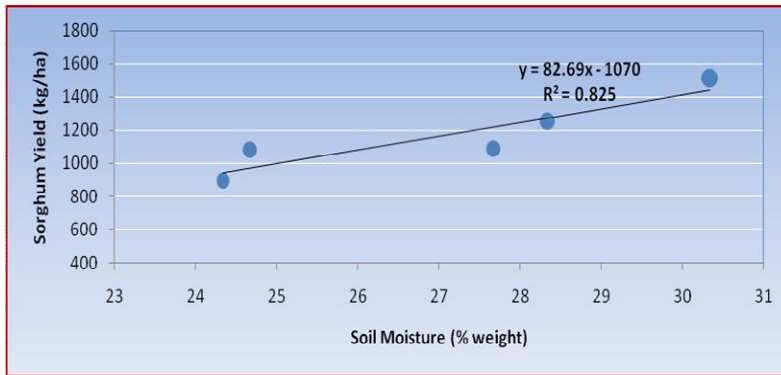

Figure 5. Relationship between sorghum yield and terminal soil moisture content in East Belesha.

Cost benefit analysis

The cost and benefit analysis was carried out for the in-situ moisture conservation structures taking into account the costs that vary which include both initial investment cost and maintenance cost every year. All other costs such as land and crop management costs are the same for all structures hence it was not considered in the analysis. The cost of labour was estimated based on labour cost during the construction period, ETB 8 per person per day. The cost of construction of contour ridges in the first year is estimated as ETB 500, including the price of animal drawn tie-ridger at ETB 250 and the remaining labour cost for construction. The prices of chickpea and sorghum were taken from the local market during the harvesting period and found as ETB 5 and ETB 4.50 kg⁻¹, respectively. The design period for trapezoidal bund, contour soil bund and contour stone bund were assumed as 10 years. The benefit terms were the yield of field crops harvested on the treated plots.

The partial cost and benefit analysis indicated that the benefit obtained from contour ridges was much better than all other structures because of low investment cost (Table 5). The net rate of return for contour ridge is 909%. Next to contour ridge application of contour soil bund gave 208% net rate of return. The least rate of return of 69% was obtained using the trapezoidal bund which is probably due to the high labour demand for construction of trapezoidal bund.

Table 5. Cost-benefit analysis of in-situ moisture conservation structures for 10 year design period

Parameters	Contour stone bund	Trapezoidal bund	Contour ridge	Contour soil bund
Design period cost	3556.8	8937.6	2750	3556.8
Annual Cost (Birr/ha)	355.68	893.76	275	355.68
Design period benefit	35127.4	35455.8	44408	45460.4
Annual benefit (Birr/ha)	3512.74	3545.58	4440.8	4546.04
Cost-Benefit ratio	9.88	3.97	16.15	12.78
Internal rate of return (IRR, %)	167%	69%	909%	208%

Conclusion and Recommendations

From the two year study it can be concluded that contour soil bund conserves more soil moisture alternately with trapezoidal bunds than other structures and gave the highest yield in rainfed cropping. On the other hand, since construction of tie-ridge using animal drawn ridger is simple and less costly, contour ridges gave the highest internal rate of return followed by contour soil bund. Relatively, contour stone bund constructions in moisture stress areas do not provide better benefit of soil moisture conservation and yield of field crops.

Though the construction of trapezoidal bund on cultivated areas have relatively low rate of return due to its high investment cost, this structure conserves better soil moisture which is beneficial for crops grown in residual moisture. It is also possible to redesign the trapezoidal bund to incorporate spillway so that the excess water can be drained off to avoid water logging. Sometimes when labor cost is cheap, interested farmers are encouraged to use trapezoidal bund for the production of field crops in dry land areas of East Belessa and similar moisture stress areas. Therefore farmers in Belessa areas are advised to construct contour soil bund, contour ridges and trapezoidal bund on their farm lands to improve yield of rainfed cropping.

References

- Critchley, W. and Siegert, K. 1991. Water harvesting: a manual for the design and construction of water harvesting schemes for plant production. FAO, Rome.
- Reddy, M.S. and Kidane Georgis. 1993. Dryland farming research in Ethiopia: review of the past and thrust in nineties. IAR, Addis Ababa.
- Saxton, K.E. and Rawls, W.J. 2006. Soil Water Characteristic Estimates by Texture and Organic Matter for Hydrologic Solutions, USA Department of Agriculture-agricultural research service, USA.

Quantifying rill erosion by surface runoff on cultivated lands at Debre Mewi watershed in West Gojjam

Assefa Derebe Zegeye^{1‡}, Tammo S. Steenhuis², Selamyihun Kidanu³,

[‡]Email: assederebe@gmail.com

¹Adet Agricultural Research Centre, ARARI, P.O. Box 08, Bahir Dar, Ethiopia

²Department of biological and environmental engineering, Cornell University, Ithaca, NY 14853, USA

³Sustainable Water Harvesting and Institutional Strengthening in Amhara, P.O.Box 325, Bahir Dar, Ethiopia

Abstract

In Ethiopia, rill erosion is commonly observed on agricultural fields with moderate and steep slope gradient conditions. It is considered as a predominant erosion feature that led to severe gullying and land degradation. A field study based on rill erosion survey was conducted at Debre Mewi watershed near Adet Agricultural Research Centre. The objective of the study was to determine the severity and rate of soil erosion and compare the results with erosion results predicted by USLE empirical erosion model. This paper, therefore, presented and discussed the field results of rill erosion processes on 33 surveyed agricultural fields (15 fields in 2008 and 18 fields in 2009). Individual rill dimensions were measured to determine the average rate of rill erosion for each surveyed field. The results from seasonal rill measurements showed that the average rate of erosion from rills and estimated sheet erosion on the surveyed fields (average of four crop types) was 36 t ha⁻¹ in 2008 and 60 t ha⁻¹ only from tef fields in 2009. Highest rill erosion rates were observed in early July which could be attributed to the higher erosivity of the rain, high erodibility of the soil surface after a warm and dry season, and the low soil cover. It was also found that agricultural fields located on foot slopes of the catchment and fields covered with tef crop were highly susceptible to erosion. Therefore, sustainable soil management practices must be developed to reduce further degradation and restore the productivity of the eroded land.

Key words: Crop cover, rill erosion, slope position, USLE.

Introduction

Debre Mewi watershed is recognized as one of the Ethiopian highlands suffers from severe visible erosion features, such as rills, gullies and concentrated accumulations that often indicate hot spots (parts of an area that are seriously affected by soil erosion). Rills are very shallow channels that are formed by the concentration of surface runoff along depressions or low points in sloping lands. Soil erosion that occurs in areas between rills by the action

of raindrops (causing splash erosion) and surface runoff (causing sheet erosion) is called inter-rill erosion causing for about 30 % of soil loss (Gover, 1991; Bewket and Sterk, 2003). Compared to sheet erosion, rill erosion has entirely different characteristics. It removes a considerable amount of topsoil greater than sheet/inter-rill erosion. Through rills, eroded particles are transported quickly over a large distance. Large particles are more effectively transported. Rills differ from gullies in that they are temporary or seasonal features and can be easily destroyed during plowing, whereas gullies are more permanent features in the landscape (Stocking and Murnaghan, 2000). Rills and gullies constitute an “embryonic” drainage system (Mitiku *et al.*, 2006), which, if unchecked, will develop eventually in to badlands. This may involve irreversibility of the land to return it back into crop production in agricultural systems that are based on animal-drawn implements for cultivating the land (Mitiku *et al.*, 2006).

Without involving expensive instrumentation and sophisticated modeling of soil loss, field surveys of rills may yield more economical (and efficient) solutions in estimating field erosion and identifying severe local erosion areas than the application of the existing generation of erosion models (Herweg, 1996; Bewket and Sterk, 2003). It must also be treated as a means in itself to aid soil conservation (Herweg, 1996) and to inform catchment managers and decision/policy makers where to apply soil conservation. Hence, assessment of soil loss by surveying rill erosion plays a great role for soil and water conservation planning. Therefore, this study was aimed at estimation of the severity and rate of soil erosion in the Debre Mewi watershed. The specific objectives of the study were: To estimate the magnitudes of rill erosion based on crop cover types and slope positions; to compare the estimated rill erosion rates with the predicted erosion results using empirical USLE model; to recommend land management techniques that used to control rill erosion.

Materials and methods

The study area

This paper is based on a rill survey conducted on agricultural fields at Debre Mewi watershed located at 11°20'13'' N and 37°25'55'' E during 2008 and 2009. The watershed

is located South of Lake Tana about 30 km from Bahir Dar Town, the capital of Amhara Regional State in the Northwestern Ethiopian highlands. The elevation ranges between 1950 and 2309 m above sea level. The total area of the watershed is estimated to be 523 ha. The slope gradient of the watershed ranges from 8 to 30%. The dominant soil types in the watershed based on FAO classification include Nitosols located in the upper part of the watershed covering about 24% of the watershed, Cambisols located in the middle part of the watershed covering about 40% of the watershed and Vertisols located in the lower part of the watershed covering about 21% of the watershed and the other soil type is Fluvisols (15%) mostly located near and along the water bodies of the watershed.

Methodology

To assess and quantify the rill erosion magnitudes, rill erosion survey was conducted on agricultural fields. Fifteen agricultural fields covered by four major crop types (3.56 ha) in 2008 and 18 tef fields (5.38 ha) in 2009 were selected from the 523 ha land of the watershed. These fields are assumed to represent the cultivated slopes of the entire watershed. Rill survey measurements following transects were conducted on four major crop covers (tef, finger millet, wheat and maize) in the first year and one crop type (tef) in the second year along three slope positions in the catchment (upslope, mid-slope and down-slope based on their elevation). During the first year, rill magnitudes were compared across crop cover types and between the three slope positions where as in the second year (2009) rill magnitudes were compared only between the three slope positions: upslope, mid-slope and down-slope fields.

A series of transects across the slope with an average distance of 10 m between two transects was established; positioned one above another to minimize rill measurement errors and marked using sticks and stones (Hudson, 1993) as indicated in Figure 1. Traditional on-farm ditches constructed in the field for safe disposal of water were also used as transects, so that measurements of rills found between two consecutive ditches were undertaken.

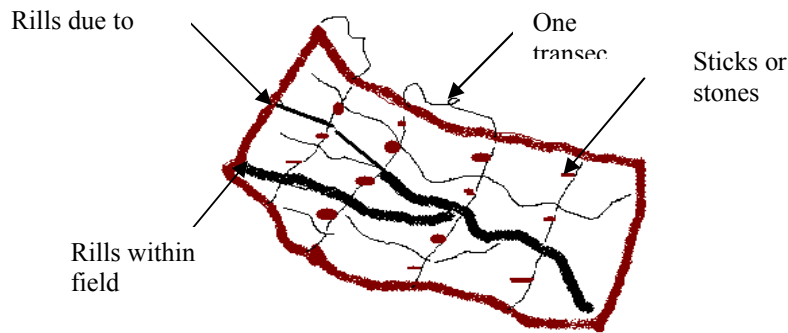

Figure 1. Transects across slope to show how rill dimensions were measured in a cultivated field.

During the months of July and August greatest rainfall amounts causing significant soil loss were recorded. And each survey field was repeatedly visited and measured immediately after rainfall storms had occurred. Rill measurements were not taken until rills were clearly noticed and thus only those rills with width above 25 cm were surveyed. Rill dimensions such as length, width and depth were measured in the surveyed fields. In each field, maximum development of rills, both in number and dimensions, was analyzed in this paper to estimate the total soil loss due to rills. Though continuous rill measurements were taken, their total soil loss rate refers to the maximum rill channel volumes. The eroded soil volumes, rill densities, areas of actual damage and other quantities were calculated from the measured rill dimensions: length, width and depth (Herweg, 1996).

The calculated volume is equivalent to the volume of soil lost from the formation of the rills. The total volume of soil loss from rills was obtained simply by summing the rill volumes (calculating as $\text{Length} \times \text{Width} \times \text{Depth}$) of all homogenous rill segments. The eroded soil volume was also expressed in terms of weight of eroded soil by multiplying the calculated volume by the measured bulk density of the soils at each surveyed fields in the site (Hagmann, 1996). The total soil loss was converted into per unit hectare of land to express the annual rate of soil loss after corrected for effective rill damage area. The area of actual damage per unit hectare was obtained from the product of length and width dimensions of each homogenous rill segment. The rill density was calculated by dividing the total rill lengths, obtained by summing up the length measurements of all the rills, by

the total area of the surveyed fields. Some simplified formulae used to calculate rill magnitudes are indicated below.

$$X = \frac{\sum (L_i W_i D_i) N_i}{10000 A} \quad AAD = \frac{\sum (L_i W_i) N_i}{100 A} \quad D = \frac{\sum (L_i) N_i}{A}$$

Where, X is the volume of rills ($\text{m}^3 \text{ ha}^{-1}$), L_i is the length of a rill (m), W_i is the width of a rill (cm), D_i is the depth of a rill (cm), AAD is the area of actual damage affected by rill erosion ($\text{m}^2 \text{ ha}^{-1}$), D is the density of rills (m ha^{-1}), A is the field area (ha), and N is the number of rills. X is equivalent to the volume of soil lost due to the formation of rills. The eroded soil volume was also expressed in terms of weight of eroded soil by multiplying X with the soil bulk density of each of the 15 fields.

Parameters including average annual rainfall, slope length, slope gradient, soil color, land cover and management practices were collected in all the surveyed fields. Finally, soil loss was estimated in the surveyed fields using the Universal Soil Loss Equation (USLE) adapted for Ethiopian conditions according to Hurni (1985b) (cited in the guide of watershed management by Ministry of Agriculture (MoA, 2001).

$$E = R * K * L * S * C * P$$

Where, E is the mean annual soil loss, R is a rainfall erosivity index, K is a soil erodibility index, L is the slope length, S represents slope steepness, C is a crop factor, P is a conservation practice factor. Hence, the amount of soil loss was estimated by this equation and compared with the measured soil loss from rills and sheet erosion.

Results and discussion

Soil loss due to rill erosion

The amount of soil loss due to rills from the total surveyed fields in 2008 and 2009 was found at 26.6 t ha^{-1} and 45 t ha^{-1} respectively (Table 1) given the average soil bulk density of 1.21 g cm^{-3} . During the survey, the contributions of other erosion features were not considered. However, rills are not the only mechanisms for soil erosion; they are always accompanied by impacts of raindrops such as sheet or inter-rill erosion. According to Zachar (1982), rill erosion underestimates 10 to 30% of the actual soil loss. Govers (1991)

also reported, as the contribution of inter-rill erosion can be more than 30% of the total soil loss in fields where rills are present. Bewket and Sterk (2003) also assumed 30% of the actual soil loss to calculate the contribution of inter-rill erosion to total soil loss. For this study, it was also assumed that the measured rill erosion rates underestimated soil loss by 25%. Therefore, having this assumption, the annual actual soil loss rates were estimated around 36 t ha⁻¹ and 60 t ha⁻¹ in 2008 and 2009, respectively.

Table 1. Classification of rills and their contribution in soil loss (2008).

Size of rills	Number of rills			Soil loss (t ha ⁻¹)			AAD (m ² ha ⁻¹)			Rill density (m ha ⁻¹)		
	US	MS	DS	US	MS	DS	US	MS	DS	US	MS	DS
Small	103	376	865	7	12	24	107	334	610	686	2299	4424
Medium	2	74	94	1	9	11	69	271	274	21	543	522
Large		3			11			363			115	
Total	105	453	959	8	32	35	176	662	885	708	2860	4946

The widths of Small rills (<25cm), medium (25 to 200cm), Large (>200cm), AAD = Area of actual damage, US = upslope, MS = mid-slope, DS = down-slope.

Table 2. Rill erosion magnitudes in 2008 and 2009.

Year	Soil loss (t ha ⁻¹)				AAD (m ² ha ⁻¹)			
	US	MS	DS	Total	US	MS	DS	Total
2008	8	23	35	27	256	662	884	717
2009	35	46	54	46	536	611	594	583

AAD = Area of actual damage US = upslope, MS = mid-slope, DS = down-slope.

This result has direct relationship with the Area of Actual Damage (AAD), the surface area covered by the rills themselves, which covered about 7.2% of the total surveyed areas. This was a significant amount, which lead to the decreasing or shrinking of size of crop producing farmlands. The productivity of the farmlands has also been decreasing due to loss of fine soil material by erosion. This result indicated that the survey area was under a high erosion risk.

Estimation of soil loss using USLE

According to Hurni (1985b), all the USLE parameters were adapted to the Ethiopian situation and corresponding values were described in the MoA watershed management manual (MoA, 2001). Using the adapted USLE the soil loss from the surveyed fields in 2008 and 2009 was predicted to be 39 t ha⁻¹ and 43 t ha⁻¹, respectively. The correlation between the two results was 72 and 75% with R² value of 0.52 and 0.57, respectively (Table 3). The low R² value was due to the fact that there were differences in slope gradient, crop cover type and other factors among the surveyed fields.

Table 3. Comparisons of measured soil loss (SL) value and USLE predicted value in 2008 and 2009 in Debre Mewi watershed.

Field number	2008			2009		
	Field size (ha)	Total SL (rill + sheet) (t ha ⁻¹)	USLE predicted Soil loss (t ha ⁻¹)	Field size (ha)	Total SL (rill + sheet) (t ha ⁻¹)	USLE predicted Soil loss (t ha ⁻¹)
1	0.27	43.8	34.4	0.26	11.2	20.7
2	0.34	83.7	73.4	0.31	70.3	49.6
3	0.41	40.6	66.4	0.48	21.8	24.8
4	0.24	31.3	69.0	0.21	68.0	44.1
5	0.16	35.6	57.1	0.31	63.6	46.9
6	0.24	36.0	29.9	0.22	82.9	59.5
7	0.23	19.9	23.9	0.17	62.8	49.6
8	0.24	39.1	45.3	0.22	38.4	37.0
9	0.25	36.8	39.2	0.45	63.8	50.3
10	0.19	10.3	18.2	0.45	71.6	41.9
11	0.24	60.7	39.6	0.41	45.7	42.3
12	0.15	23.4	27.2	0.21	80.4	30.1
13	0.19	9.3	19.0	0.26	69.5	37.2
14	0.25	14.4	25.8	0.30	92.8	49.4
15	0.17	7.6	16.8	0.15	82.4	57.9
16				0.46	83.6	59.5
17				0.32	40.4	26.5
18				0.19	68.4	38.6
Mean	3.56	36.1	39.0	5.4	62.1	42.6

The result obtained from the survey indicated that erosion in the study area was severing. As described above soil loss due to rill and sheet/inter-rill erosion, for example, in 2008 was estimated to be 36 t ha⁻¹yr⁻¹, which is equivalent to 3.6 mm per year, provided that 1 t ha⁻¹ was equivalent to 0.1 mm per year (Morgan, 1996; Tadesse, 2001). According to Basic *et al.* (2004), the erosion risk in the watershed can be estimated by the following formula:

$$\text{Erosion risk} = [\text{Erosion rate}] \div [\text{Soil loss tolerance}]$$

Assuming the mean soil loss tolerance be 10 t ha⁻¹, which was accepted as appropriate for moderate thickness of soil (Morgan, 1996; Tadesse, 2001), then the soil loss obtained from this study increased by 70% (approximately four fold of soil loss tolerance). This is also greater by 97% to soil formation, assuming the average soil formation worldwide is 0.1 mm per year (the range is from 0.01 to 7.7 mm yr⁻¹) taken from the book of Morgan (1996). According to this assumption, the Debre Mewi watershed can be characterized as high erosion risk area. Taking the top soil depth as 20 cm thick, after 50 years all the top soils with their nutrients that contain organic-rich topsoil, which was used to improve crop production in the watershed, will fall under high risk unless special attention is given to construct appropriate conservation measures to decrease this threat.

Characteristics of rill erosion on different crop cover types

Tef is the dominant cereal crop in the watershed followed by maize, finger millet and wheat. Local farmers sow tef from early July to early August, Finger millet from late may to late June, maize from late April to mid June and wheat in June. This timing has an implication on the contribution of ground cover of the croplands in reducing erosion. Tef and finger millet fields need five to seven times plowing, four times for wheat and barley, and three times for maize.

The result of the study indicated that the number and dimensions of rills were higher on tef. Hence, the erosion rate was exceptionally peak in the field plots covered with tef. From the surveyed mid-slope position fields (where the four crop cover types found), the soil loss rate on tef fields was three times greater than the rate in finger millet and wheat, and twice in maize covered fields. On the other hand, the soil loss rate on tef fields was increased by

70% from finger millet fields, 68% from wheat fields and 40% from maize fields. Soil loss in all crop cover types, except millet and wheat, showed significant difference to each other. In the case of area of actual damage by rills, only tef fields showed significant difference with all surveyed crop cover types ($p < 0.01$).

Table 4. Multiple comparisons to show significant differences of soil loss among crop cover types in 2008.

(I) CT*	(J) CT	Soil Erosion ($t\ ha^{-1}$)		AAD ($m^2\ ha^{-1}$)	
		MD (I-J)	Sig.	MD (I-J)	Sig.
Maize	Wheat	6.4*	0.00	51	0.13
	Millet	6.8*	0.00	44	0.23
	Tef	-4.7*	0.02	-340*	0.00
Wheat	Maize	-6.4*	0.00	-51	0.13
	Millet	0.4	0.84	-7	0.84
	Tef	-11*	0.00	-391*	0.00
Millet	Maize	-6.8*	0.00	-44	0.23
	Wheat	-0.4	0.84	7	0.84
	Tef	-11.5*	0.00	-384*	0.00
Tef	Maize	4.7*	0.02	340*	0.00
	Wheat	11*	0.00	391*	0.00
	Millet	11*	0.00	384*	0.00

*CT is crop type, AAD is area of actual damage, MD is mean difference, Sig. is significance (P), * denotes significant difference at $P < 0.05$.

One reason why tef fields scored this amount of soil loss was that the land was prepared by plowing repeatedly (5-7 times) before sowing. This was because, the farmers believed that it overcomes weeds and gives better crop yields. This number of plowing resulted the soil on tef fields becomes loose, poor in structure and hence more susceptible to soil erosion. The other reason was that the period of land preparation for tef is during high rainfall season, which increased the vulnerability of the land for erosion.

Furthermore, it should be considered as one reason that the activities practiced to decrease the roughness of tef fields while sowing. From field observation and personal interview, the well prepared rough surface of tef field due to repeated plowing was trampled by animals

(mostly by farm animals and donkeys) just before sowing. This activity is also common on finger millet fields except, in this field, the activity is done twice just before and after sowing. This was because the farmers believed that unless it is packed and compacted enough, the crop would dry before the expected crop calendar. Moreover, as it was observed during the survey, the root of tef crop was neither strong nor deep enough to protect the soil from high surface runoff. According to Hurni (1985a), the annual average crop cover factor (C-factor) of the Universal Soil Loss Equation (USLE) is 0.25 for Ethiopian tef field and others have less than this value. All the above reasons confirmed that tef fields were very susceptible for soil erosion process compared to other crop cover types.

In finger millet crop lands, at the beginning of rill survey the numerous very-shallow rills were observed. However, after one month (up to the middle of August) almost all rills were disappeared. This might be because of the redistribution of sediments as the rill dimensions were very small due to highly compacted area by animals. The highly dense cover effect of finger millet was also another major factor to the disappearance of rills.

Rill erosion hardly exists in wheat field since the surface, before and after sowing, was rough. This increases infiltration, which in turn decreases runoff that was considered to be the major source of rills and sheet erosion in the area. The growth cover of wheat was faster than other surveyed crop covers before the roughness became smooth due to high rainfall and runoff sealing effect. Soil loss rate in maize crop fields was also higher next to tef fields. This may be due to scattered and sparse plantation and may be the plant area coverage was slowly increased. At weeding time, the maize cover again decreases until the leaves become dense to decrease the rainfall erosivity by the interception process.

Characteristics of rill erosion on different slope positions

Rill erosion is the most visible mechanism of soil loss from sloping cultivated land (Herweg, 1996). The results of the ANOVA indicated that the soil loss from rills, the area of actual damage and rill density were significantly different among the three slope positions ($p = 0.0008$, $p = 0.0001$, $p = 0.0004$) at 5% probability level. Since all surveyed

fields were cultivated with the same crop type (tef), the rate of erosion in the down-slope fields was increased by 15% from that of mid-slope fields and by 35% from that of the upper slope fields.

Table 5. Rill erosion magnitude on tef fields at three different slope positions in 2009.

Slope positions	Soil Loss (t ha ⁻¹)	AAD (m ² ha ⁻¹)	RD (m ha ⁻¹)
Down slope	54 ^{a*}	594 ^a	19434 ^a
Mid-slope	46 ^b	611 ^a	17555 ^b
Upslope	35 ^c	536 ^b	11446 ^c

*AAD = area of actual damage, RD = rill density. *Means in a column followed by similar letters are not significantly different at P<0.05.*

The mid slope fields scored relatively higher area of damage (Table 5). This was because all of the rills occurred in this position are found and classified as large that were caused by surface runoff coming from the upland fields. In down-slope fields, most of the rills were initiated within fields. Hence, the widths of rills were smaller compared to the mid-slope tef fields.

The slope lengths in the down and mid-slope fields showed significant difference with upslope fields'. Statistically, no significant difference of slope length and slope gradient was observed between down slope and mid-slope fields, and between mid- and upslope fields, respectively. However, the slope gradient in the down slope fields showed significant difference with the mid- and upslope fields. Hence, the average critical distances, the length from the upper field boundary to the place where the rills began, were a bit longer than the fields in the down-slope field positions as the slope gradient of mid-slope fields was less than down-slope fields. This slope distance influenced the length of the rills in the fields.

Conclusions and Recommendations

Land in the Debre Mewi watershed suffers from severe erosion. Gullies and their effects are increasing at alarming rate and threatening the watershed inhabitants. Basic natural

resources like soil, water and vegetative cover in the watershed are deteriorating. Based on field observations, the intensity of the rainfall coupled with poor vegetation cover has aggravated the soil erosion in the watershed. Hence, crop production and soil productivity have been decreasing overtime. So far, farmers hardly undertake action to reduce erosion. Only few soil conservation structures accompanied with poor management practices at household level were observed during the field survey. If nothing is done to correct the existing situation of the area, the adverse effect of erosion will jeopardize the efforts of the community and in the near future, the farmers will remain with severely degraded lands.

Therefore, sustainable soil and land management practices must be developed to reduce further degradation and restore the productivity of the eroded land. The management options to reduce soil erosion are to implement effective and efficient soil conservation measures and/or to change the cropping system from inappropriate to more sustainable and appropriate farming practices. Soil conservation measures including terraces and bunds as well as semi-permeable structures like grass strips are used as barriers to holdback runoff and the sediment carried with it. Agronomic measures like contour plowing have the advantage to reduce runoff and soil loss. Changing to cropping systems that need less tillage and improve the soil structure can reduce the problem of erosion. Especially the soil conservation designers should find a mechanism in such a way that farmer can plant tef to get high profit while its contribution to erosion should be minimized. Traditional ditches are not recommended as an important option to conserve soil. Moreover, extension workers and land use planners can use the rill survey method to assess and quantify soil loss and identify erosion risk areas at field level in a simple way and shortest time, and then after to plan effective and site dependent soil and water conservation measures.

References

- Basic F., Kistic, I., Mesic, M., Nestroy, O., and Butorac, A. 2004. Tillage and crop management effects on soil erosion in central Croatia. *Soil & Tillage Research* 78: 197–206.

- Bewket, W. and Sterk, G. 2003. Assessment of soil erosion in cultivated fields using a survey methodology for rills in the Chemoga watershed, Ethiopia. *Agriculture, Ecosystems and Environment* 97: 81–93.
- Govers, G. 1991. Rill erosion on arable land in central Belgium: Rates, controls, and predictability. *Catena* 18: 133-155.
- Hagmann, J. 1996. Mechanical soil conservation with contour ridges: cure for, or cause of, rill erosion? *Land degradation & development* 7:145-160.
- Herweg, K. 1996. Field manual for assessment of current erosion damage. Soil conservation research programme (SCRIP), Ethiopia and centre for development and environment (CDE), University of Berne, Switzerland.
- Hudson, N.W. 1993. Field measurement of soil erosion and runoff. Food and Agricultural Organization (FAO) of the United Nations Amphthil, United Kingdom.
- Hurni, H., 1985a. Erosion-productivity systems in Ethiopia. In: Proceedings of the Fourth International Conference on Soil Conservation. Venezuela.
- Hurni, H. 1985b. An ecosystem approach to soil conservation. In: El-Swaify, S.A., Moldenhauer, W.C., Lo, A. (Eds.), *Soil Erosion and Conservation*. Soil Conservation Society of America, Ankey, Iowa, pp. 759–771.
- MoA (Ministry of Agriculture). 2001. A guide to watershed management, Ethiopia.
- Mitiku Haile, Herweg, K. and Stillhardt, B. 2006. Sustainable land Management- a New Approach to Soil and Water Conservation in Ethiopia. pp.79-89, Mekele University
- Morgan, R.P.C. 1996. *Soil Erosion and Conservation*, second ed. Longman Silsoe College, Cranfield University.
- Stocking, M. and Murnaghan, N. 2000. Land degradation: Guidelines for field assessment. Norwich: Overseas Development Group, University of East Anglia. Soil conservation planning at the small watershed level using RUSLE with GIS: a case study in the Three Gorge Area of China, *CATENA*, 55 (1): 33-48 JAN 5 2004.
- Tadesse, G. 2001. Land degradation: a challenge to Ethiopia. *Environmental Management* 27: 815–824.
- Zanher, D. 1982. *Soil Erosion, Developments in Soil Sciences*, Elsevier, Amsterdam.

Evaluation of deficit irrigation for potato production at Sekota, Wag Himra

Demlie Gebresillassie

Email: demdgs257@gmail.com

Sekota Dryland Agricultural Research Centre, P.O.Box 62, Sekota

Abstract

The field experiment was conducted on potato during the 2006 and 2007 dry season at one of the experimental sites of Sekota Agricultural Research Center, Woleh. The objectives were to identify the amount of deficit and the periods during which water deficit would have limited effect on potato yield, and the periods with maximum water productivity. The method of irrigation application was furrow irrigation. Eight treatments (independent application of 100%, 75%, 50%, and 25% of the crop water requirement (CWR) at the four growth stages; application of 25% of the CWR either at the 1st or 2nd or 3rd or 4th growth stage and 100% application for the other stages) were evaluated in three replications in a RCBD. Irrigation water requirement was determined using CROPWAT program by using climate, rainfall, crop, and soil data as input data. Results showed that 75% water deficit either at the first or fourth growth stage gave comparable and statistically similar yield with that of 100% full watering. Tuber yield reductions of 64%, 39% and 28% were observed with the application of 25%, 50% and 75% of the CWR at all stages, respectively. About 35% and 29% yield reduction was obtained by applying 75% water deficit either at second or third growth stage, respectively. Taking into consideration both yield advantage and water use efficiency, 75% deficit irrigation application only at the 4th growth stage and full irrigation application at other stages is recommended as it gave high tuber yield and saved 1670 m³ ha⁻¹ of irrigation water.

Key words: Deficit irrigation, CROPWAT, moisture stress, potato, water productivity.

Introduction

One of the irrigation management practices which could result in water saving is deficit irrigation. By maintaining the moisture content of the soil below the optimum level during specific growth stages of crops in the season or throughout the growing season, it is possible to identify the periods during which water deficit would have a limited effect on crop production. In a traditional irrigation using furrow irrigation system, where water is allowed to flow in small channels between crop rows, the water is gradually absorbed into the bottom and sides of the furrow to wet the soil. But the problem here is that the water

reaches to the furrows or to the fields without applying appropriate amount and duration of irrigation or without knowing exactly the crop water requirement and required irrigation interval. They simply allow water to flow in to the irrigated fields which often leads to the water being lost in the form of evaporation and deep percolation in all growing stages. Therefore farmers do not get an optimum yield and their water use efficiency is poor.

Potato (*Solanum tuberosum*) is a leading food and vegetable crop in many parts of Ethiopia. It is mainly produced during the rainy season. Since potato can be harvested and consumed during the season when food unavailability is common, it is considered as a food security crop in most of the drought prone areas. Recently, potato production is expanding using small scale irrigation systems. The yield however, has remained stagnant. This low yield is caused, in part, by improper irrigation management. The crop is very sensitive to irrigation. The yield quality and disease resistance are greatly influenced by timing, amount and frequency of irrigation applied. The farmers, on the other hand, apply water to the crop regardless of whether the plant actually needs water at specific growth stage (Kirda *et al.*, 1999). From an economics standpoint, maximum profit for farmers may be obtained with the fulfillment of the entire crop water requirements.

In the dry land countries like Morocco, they manage their water by stressing the crop at one of the growth stages; initial stage, vegetative development, yield formation or root growth and ripening. By doing so, they simply select the optimum yield rather than the maximum yield and manage and save the limited water easily. Considering moisture stress situations in our country, particularly in the Sekota dryland areas, where the amount of rainfall is small and erratic and thus there is scarcity of water sources for irrigation production, deficit water management methods should be sought and applied to maximize crop production. The intention of this study was to make inferences on water saving on irrigated areas through adequate irrigation management, and at the same time to evaluate and identify crop growth stages which withstand moisture stress with limited effect on crop yield. Thus, an experiment was conducted with the objective of identifying sensitive crop growth stages to water stress, and to identify the amount of deficit and corresponding growth stages during which potato could withstand water stress with limited effect on its yield.

Materials and methods

The experiment was conducted at Woleh in Sekota Woreda during the 2006 and 2007 irrigation seasons. The experimental site is located at 12° 35' 24'' N and 39° 05' 48'' E with an altitude of 2126 m above sea level (a.s.l). The area has total annual rainfall of 830 mm, mean maximum temperature of 25 °C, and mean minimum temperature of 8 °C. The soil of the experimental site was silt clay soil. Potato was planted with a spacing of 75 cm between ridges and 30 cm between plants. The recommended fertilizer rate of 110 kg N ha⁻¹ and 90 kg P₂O₅ ha⁻¹ was applied.

Crop water requirement and irrigation requirement was determined using CROPWAT program. The programme uses locally collected input data for crop, soil, and climate. Crop water requirement and irrigation interval was computed using FAO modified Penman-Monteith equation. Measurements of soil moisture content were done at the beginning of each crop stage. Soil samples were taken from the experimental field to determine the physicochemical properties of the soil. Thirty years metrological data for Lalibela and Maichew stations were collected from the National Meteorological Service Agency. Interpolations using LocClim software were performed to compute climate variables for the study location, Sekota.

Four crop growth stages were subjected to water deficit at different stress levels. Accordingly, the following water regimes were evaluated using Completely Randomized Block Design (RCBD) with three replications. Plot size was 3 m x 3 m and there was 0.5 m between plots, blocked by ridges to protect water flowing outside the plot. The method of irrigation was furrow irrigation with furrow spacing of 75 cm, width of 20 cm and depth of 15 cm. The right amount of water was measured by calibrated bucket of known volume. Information on date of water application, depth of irrigation water, rainfall, total number and weight of tubers were collected. Analysis of variance was conducted for the combed data across years using SAS.

Table 1. Description of water regimes applied for the experiment.

	Growth stage/period				Description
	P ₁	P ₂	P ₃	P ₄	
Water regimes	25	30	35	40	LGP (in days)
1111	1	1	1	1	Irrigate 100% of CWR
25%	25%	25%	25%	25%	Irrigate 25% of CWR
50%	50%	50%	50%	50%	Irrigate 50% of CWR
75%	75%	75%	75%	75%	Irrigate 75% of CWR
Stress during one growth stage					
0111 (0= 25%CWR)	0	1	1	1	Stress during P ₁
1011 (0= 25%CWR)	1	0	1	1	Stress during P ₂
1101 (0= 25%CWR)	1	1	0	1	Stress during P ₃
1110 (0= 25%CWR)	1	1	1	0	Stress during P ₄

Results and discussion

Effect of deficit irrigation on potato tuber yield

Significantly higher tuber yields were recorded with the application of full amount of the crop water requirement at all stages and 75% water deficit either at initial or last crop growth stage (Table 1). Significantly lower tuber yield was recorded with the application of 25% of the crop water requirement at all crop growth stages. The highest and significant tuber yield reduction (4.38 ton ha⁻¹) was recorded with applying only 25% crop water requirement throughout all growth stages. Tuber yield reductions of 64%, 39% and 28% were recorded with the applications of 25%, 50% and 75% of the total crop water requirement at all stages, respectively. About 35% and 29% tuber yield reductions were also recorded with applying 75% water deficit at the third and second crop growth stages, respectively (Table 1). This was attributed to the fact that adequate watering conditions early in the season lead to the development of an abundant leaf cover and shallow root depth (Bazza, 1999). When a severe stress follows, the crop rapidly depletes the soil water stored in the root zone and wilts before the completion of additional root development at greater soil depth. The above statement also supported by Bazza (1999), on different vegetable crops and for some cereals and he concluded that minimum yield was gained during the full stress, but stressing the crops during initial and final stage of the growing

season did not affect the crop yield significantly. It can be concluded that under limited water, it is better to stress the crop during early and end of the season. By doing so, the crop adapts to limited watering conditions with the stress not being severely concentrated in any one-time period.

On the other hand, the amount of water saved was 4670 m³ ha⁻¹ and 3110 m³ ha⁻¹ by applying 25% and 50% of the crop water requirement throughout the growing period, respectively. This reduction in the amount of water led to tremendous tuber yield reduction, 4.38 and 2.65 ton ha⁻¹, respectively. This yield reduction was much higher than the yield reduction observed during stress occurred at the different growing stages. However, applying 75% water deficit at the last growth stage saved about 1670 m³ ha⁻¹ of water with limited effect on tuber yield. This water could irrigate an additional area of about 0.37 ha.

Table 2. Effect of deficit irrigation on the tuber yield and water productivity in potato at Sekota combined across years (2006 and 2007).

Treatments	Tuber yield (kg ha ⁻¹)	Irrigation water applied (m ³ ha ⁻¹)	Saved water (m ³ ha ⁻¹)	Yield reduction (%)
Irrigate 100% CWR*	6895a [‡]	6230	0	0.0
Irrigate 25% of CWR	2511c	1560	4670	64
Irrigate 50% of CWR	4243b	3120	3110	39
Irrigate 75% of CWR	4931b	4680	1550	28
75% deficit at initial stage	6618a	5800	430	4
75% deficit at second stage	4885b	5280	950	29
75% deficit at third stage	4516b	4600	1630	35
75% deficit at last stage	6886a	4560	1670	0.14
CV (%)	16.14		-	-

*Crop water requirement. [‡]Means followed by the same letters are not significantly different at $p \leq 0.05$.

Effect of deficit irrigation on water productivity

The lowest yield reductions were observed when 75% deficit irrigation was applied at the last and initial crop growth stages, respectively (Table 1). However, the yield reduction can be compensated by using the saved water to irrigate additional area. It was observed that

430 and 1670 m³ water ha⁻¹ could be saved by applying deficit irrigation, stressing during initial and last growth stages of the crop, respectively (Table 1). Using the saved water, an extra 0.5 and 2.5 ton ha⁻¹ tuber yield of potato could be produced by irrigating more irrigable area (0.07-0.37 ha). The other irrigation regimes were not found economical, as the yield reductions were high and the water saved could not compensate the yield reduction. It is, therefore, advantageous to apply deficit or stress at the initial and maturity stages of the crop to save more water and to irrigate more areas, without significant yield reduction.

Conclusion and Recommendations

Results revealed that high potato yields could be obtained with water stress imposed at the early and late crop stages, provided that adequate watering takes place during the rest of the growth stages. The most critical period for irrigation was the third growth stage. This period coincides with the highest water requirement and the crop cannot withstand water deficit at this stage. It is possible to increase water productivity of the irrigation system by stressing the potato crop at the initial and last growth stages and divert the saved water to increase irrigated area. Considering both yield advantage and water use efficiency, 75% deficit irrigation application only at the fourth growth stage and full irrigation application at other growth stages gave high tuber yield and saved 1670 m³ ha⁻¹ of irrigation water. Thus, 75% deficit application only at the fourth growth stage of potato is recommended.

References

- Bazza, M. 1993. Contribution to the improvement of irrigation management through water deficit irrigation, Rumania.
- Kirda, C., Moutonnet, P., Hera, C. and Nielsen, D.R. 1999. Crop yield Response to Deficit Irrigation, The Netherlands.



AGRICULTURAL MECHANIZATION & FOOD SCIENCE

Modification and evaluation of sorghum thresher

Geta Kidanemariam¹ and Abay Gelawneh²

¹Email: getakiddan@yahoo.com

¹Bahir Dar Agric. Mechanization and Food Science Research Center

²Kombolcha Poultry and Agricultural Mechanization technology promotion Center

Abstract

In Amhara Region, sorghum is among the leading cereals by area coverage. In the region, sorghum is threshed in a traditional way by trampling of animals, which is cumbersome and inefficient. This method of threshing requires more labour and results in less recovery percentage of the crop. Taking these factors into consideration, modification of the Bako made maize sheller was done so as to make appropriate for threshing sorghum. Performance evaluation of the modified thresher was done extensively in the field. The test results revealed that threshing capacity, threshing efficiency, cleaning efficiency, recovery percentage and labour productivity increased significantly. Finally in this study even though, promising results are recorded regarding the threshing performance of the modified thresher, extensive tests need to be undertaken under farmer's field condition using different variety to verify the output of this paper under different condition. In addition economic advantage of the technology should be studied.

Key words: Maize sheller, sieve overflow, sorghum thresher, threshing capacity, threshing efficiency.

Introduction

The traditional threshing floor for sorghum like the other crops is usually made by smearing the ground with cow dung or irrigating with water and leaving to dry for some time. During threshing the crop to be threshed is laid on the floor and several animals tread on it. The animals go around the threshing floor over the crop for some time and are taken out intermittently to turn the unthreshed crop from bottom up for efficient treading. Threshing sorghum is tedious work. It takes 5:25 ox hr q⁻¹ and 3:50 man hr q⁻¹ for trampling and 6 man hr q⁻¹ for cleaning. Despite the long time spent on threshing and cleaning, some times more than 30-40% of unthreshed crop is observed in the kernels. During the operation care is taken not to under thresh or over thresh in order to prevent cracking and damaging of the kernels. The threshing season normally lasts 2- 3 months after harvesting, which is possibly extended with high yielding varieties. Threshing may

not be completed in this time due to lack of treading animals. The delay in the completion of the threshing operation within the safe time limit will expose the product to unfavorable weather resulting in high level of quality loss and insect and rodent attack.

The traditional method of threshing sorghum requires large labor and results in low recovery percentage and quality of the crop. This implies that sorghum productivity is greatly affected by the threshing method practiced. Therefore, this study was conducted with the objective of modifying the Bako made maize sheller so as to thresh sorghum and evaluate the threshing performance.

Materials and methods

Modification of parts

A two stage improvement was done in modifying the Bako made maize sheller to suit for threshing sorghum. After the first modification, preliminary test was conducted to gather required information for further modification. Clearance between concave sieve and beater, perforated concave sieve opening hole diameter and perforated shaking sieve opening hole of the Bako made maize sheller were modified to suit the sheller for threshing sorghum (Table 1).

Table1. Modifications in the Bako made maize sheller to thresh sorghum.

Parameters modified	Bako	1 st modified	2 nd modified
Clearance between concave sieve and beater (mm)	60	45	40
Perforated concave sieve opening hole diameter (mm)	16	10	8
Perforated shaking sieve opening hole (mm)	14	8	7

In addition, during the second modification the following changes were made:

- Peg (bended round bar) was welded on the beater at the inlet side to improve feeding rate and then to increase threshing capacity (Figure 1).
- The size and shape of feeding hopper was re-designed by incorporating feeding table with the opening gate cover made from canvas in order to have enough space for the material to be threshed and reduce loss of grain due to hopper overflow (Figure 1). Since

the concave sieve has to be changeable for sorghum threshing and maize shelling activity, to make assembling and disassembling activity easy the side plate that was previously welded to the concave sieve and blower housing been designed to be attached with bolt and nut in both sides rather than being welded.

- The hopper and feeding table shape and size was changed for better threshing capacity and to decrease loss and table overflow (Figure 2).



Figure 1. Beaters of maize sheller and modified sorghum thresher.

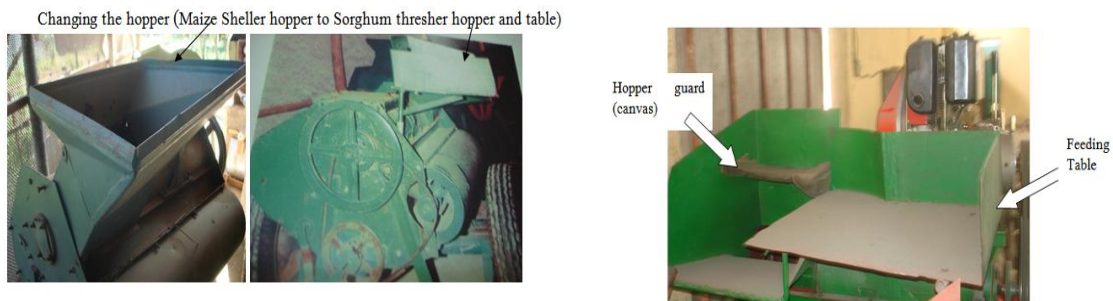

Figure 2. Modified hopper parts of the sorghum maize thresher.

Testing and Evaluation

Testing and evaluation of the 1st modified thresher

After the prototype has been developed, preliminary test was conducted at the Kobo sub center trial site of Sirinka Agricultural Research Center using three types of improved sorghum varieties namely Gobiye, Teshale, and 76-T₁#23 following the FAO standard test procedure (Smith *et al.*, 1994). Among the drawbacks observed during the first test that were found to be critical and had to be solved were:

- Clogging of concave sieve opening hole by stalk and spent panicle.

- Assembling and disassembling of concave and shaking sieve was found challenging to the farmers and even workshop technicians.
- The threshing capacity of the machine was not found good enough as compared to the rated speed (horse power) of the driving units.
- Less cleaning efficiency.

By considering these problems the second modification was intended in order to improve the overall working conditions.

Testing and evaluation of the 2nd modified thresher

During testing the first modified thresher merits and demerits of the thresher were observed and recorded and then design parameters were determined. Using these parameters, the second prototype was developed. Preliminary performance test was conducted for six hour using different sorghum varieties to observe its technical fitness for testing. Then, three tests were conducted at Sirinka Agricultural Research Center using the sorghum variety Gobiye. Each test was replicated three times. The tests were done according to the FAO standard test procedure (Smith *et al.*, 1994).

Results and discussion

Results of the 1st modified sorghum thresher

As result of modification from the original one, threshing capacity and threshing efficiency of the thresher increased by 26.9% and 2.47%, respectively and cleaning efficiency decreased by 8.64% (Table 2). Hopper overflow of the modified sheller has been recorded to be 1.75%. Further, the sheller required 7-10 man days to run the machine efficiently.

Table 2. Test result of the first modified sorghum thresher.

Parameter	Value
Actual threshing capacity	0.723 t hr ⁻¹
Theoretical threshing capacity	1.035 t hr ⁻¹
Cleaning efficiency	93.3%
Threshing efficiency	100%
Feed rate	not recorded

Results of the 2nd modified sorghum thresher

The result of the test from the second modified engine driven sorghum thresher is tabulated as in Table 3.

Table 3. Test result of the second modified sorghum thresher.

No.	Description	Test Number			Average
		1	2	3	
2	Moisture content average (%)		6.78		
3	Grain:spent panicle ratio		3.96:1		
4	Threshing drum speed (rpm)	930	880	730	845
5	Feed rate (t hr ⁻¹)	2.117	2.374	2.612	2.368
6	Threshing capacity (t hr ⁻¹)	1.44	1.67	1.87	1.66
7	Threshing efficiency (%)	100	100	100	100
8	Cleaning efficiency (%)	90.98	91.65	89.46	90.69
9	Unthreshed grain (%)	-	-	-	-
10	Blown grain (%)	0.0160	0.0265	0.0178	0.0201
11	Sieve overflow (%)	2.285	0.9375	0.2075	1.143
12	Hopper (table) overflow (%)	0.640	0.3219	0.6197	0.5271
13	Total loss (%)	2.9416	1.2859	0.8447	1.515
14	Labor requirement (lb-hr q ⁻¹)	0.422	0.361	0.320	0.367
15	Fuel consumption (lt hr ⁻¹)	1	1	1	1
16	Panicle weight (g)	70.26	61.96	54.56	62.26
17	Length of panicle (mm)	271	264	276.66	270.55
18	Diameter of panicle (mm)	32.15	32.86	30.35	31.78
19	1000 grains weight (g)	29.3	28	28	28.43
20	Ave. grain length (mm)	4.28	4.19	4.37	4.28
21	Ave. grain width (mm)	4.07	4.00	4.08	4.05
22	Ave. grain thickness (mm)	2.54	2.50	2.53	2.52
23	Ave. stalk diameter (mm)	9.63	8.96	8.57	9.05

The test result showed that, threshing capacity has increased by 60.4% and cleaning efficiency has decreased by 2.8% when compared with the first modified diesel engine driven sorghum thresher (Table 4). This may be due to clogging of sieve by well threshed impurities. Increasing the threshing cylinder speed resulted in more imparts on the sorghum head introduced to the concave. This result is in line with the results of Simonyan *et al.*

(2006). They stated that with an increase in drum speed the materials other than grain are also chopped into fine particles, which results in more materials load being delivered to the sieve for separation. Also, the increased cylinder speed results in an increased range of particle sizes and formation of minute particles, which aerodynamically resembles sorghum grain, thereby creating challenges in cleaning operation.

Table 4. Performance of the two modified sorghum threshers.

Parameters	1 st modified thresher	2 nd modified thresher
Threshing capacity (t hr ⁻¹)	0.72	1.67
Threshing efficiency (%)	100	100
Cleaning efficiency (%)	93.3	91.63

From the three selected rpms of the drum the maximum cleaning efficiency of 91.7% was recorded at 880 Rpm (Figure 3). As Rpm increased cleaning efficiency did not increased correspondingly. This could be because as rpm of the beater increased the spent panicles and stalks might have been over threshed and impurities were not removed easily.

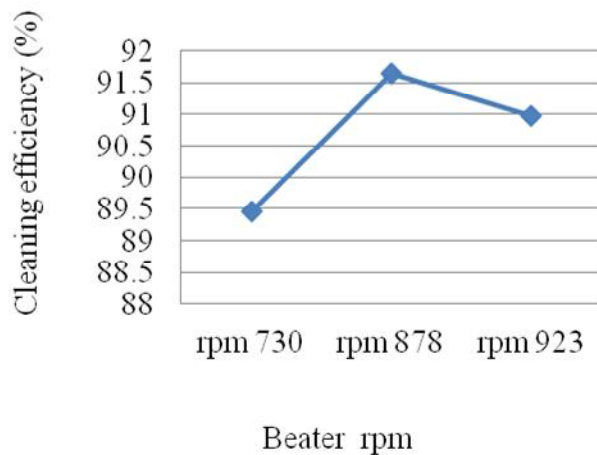

Figure 3 . Relation between Rpm and cleaning efficiency in a sorghum thresher.

The maximum threshing capacity of 1.87 t hr⁻¹ was recorded at 730 Rpm (Figure 4). It was observed that threshing capacity decreased as the Rpm of threshing drum increased. This is due to the fact that as rpm of the beater increased, the pegs did not get sufficient time to draw in the material to be threshed. As result, they bring repelling effect and also the inlet

hole of the concave is at the center of the drum, hence the panicles can be pushed back by the tangential force created on the pegs, poor feeding rate and then decrease the threshing capacity.

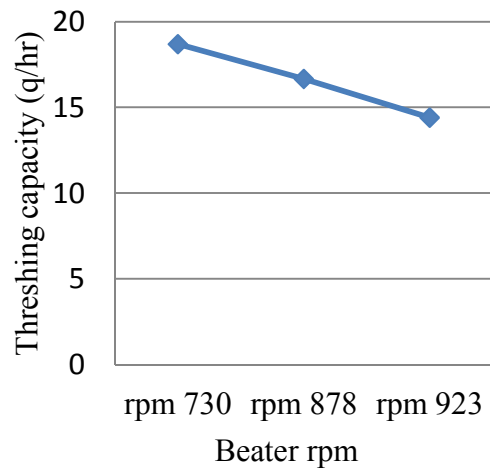

Figure 4. Relation between rpm and threshing capacity in a sorghum thresher.

The highest sieve overflow of 2.29% was recorded at 925 Rpm (Figure 5). It was observed that as Rpm increased sieve overflow also increased.

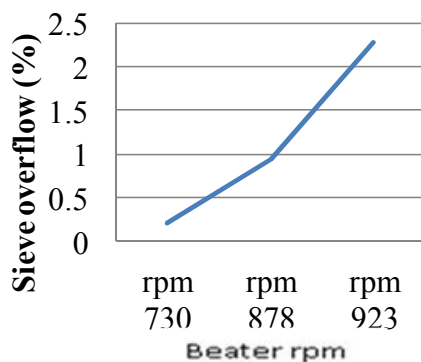

Figure 5. Relation between rpm of the beater and sieve overflow in a sorghum thresher.

Conclusion

- The capacity of the improved sorghum thresher is better than the previous thresher (from 0.7 to 1.67 t hr⁻¹) and can solve the threshing problem in sorghum.
- For efficient threshing the optimum Rpm of the beater should be between 730 and 880 Rpm.
- To use this thresher for efficiently the concave sieve has to be cleaned at the end of each threshing activity.
- To use this thresher for maize shelling and sorghum threshing activity interchangeably, the following items should be supplied as an optional accessory that are used for sorghum threshing. These are feeding hopper, feeding table, straw walker, concave sieve without its attachments, shaking sieve, guard that is assembled to the feeding hopper, and pegs with their bolts and nuts.
- Promising results were recorded on the performance of the modified thresher. Therefore, extensive tests need to be undertaken under farmers' field condition using different variety to verify the results under different condition. In addition economic advantage of the technology should be studied.

References

- CSA (FDRE, Central Agricultural Census Commission). 2003. Ethiopian Agricultural Sample Enumeration, 2001/02 results for Amhara Region. Statistical Report on Area and Production of Crops, Part II. A, Addis Abeba, Ethiopia.
- Smith, D.W., Sims, B.G. and O'Neill, D.H. 1994. Testing and evaluation of agricultural machinery and equipment: Principles. Food and Agriculture Organization of the United Nations, Rome, Italy.
- Simonyan, K., Yiljep, Y. and Mudiare O. 2006. Modeling the Cleaning Process of a Stationary Sorghum Thresher. Agricultural Engineering International: the CIGR E journal. Manuscript, P M 06 012. Vol. VIII.



FORESTRY

Floristic diversity, regeneration status and vegetation structure of the woodland vegetation in Metema area, Amhara National Regional State, Northwestern Ethiopia

Haile Adamu¹, Tamrat Bekele², Gemedo Dalle³

¹Sekota Dryland Agricultural Research Center, P.O.Box 62, Sekota, Ethiopia

Email:mamnaturepal@yahoo.com

²Addis Ababa University, Faculty of Life Sciences, P.O.Box 1176, Addis Ababa, Ethiopia

³Institute of Biodiversity Conservation, P.O.Box 80119, Addis Ababa, Ethiopia

Abstract

The study was conducted in 2008 in the broad-leaved deciduous woodland of Metema in the northwestern Amhara regional state, Ethiopia to determine plant species composition, diversity, regeneration status and population structure. A selective approach with a systematic sampling design was used. A total of 74 quadrats, each with the size of 25 m x 25 m at an interval of 150 m to 200 m were laid along the established transect lines, following the homogeneity of the vegetation. For the assessment of seedling and sapling, two subquadrats each with the size of 2 m x 5 m were established at opposite sides of every baseline. For herbaceous, five subquadrats each with the size of 1 m x 1 m were established at four corners and center of every quadrant. Results indicated that 87 vascular species belonging to 74 genera and 36 families were identified. Fabaceae was the dominant family with 16 (18.39%) species in 13 genera. The Shannon Weiner diversity index and evenness were 3.67 and 0.82, respectively, which implied that the area was endowed with rich floral diversity with good distribution pattern. The population structure in cumulative diameter class frequency distribution revealed inverted-J-shape with very high decrease in diameter class two, which is an indication of poor population status. The analysis of selected species also resulted in four general patterns i.e., interrupted Inverted-J-shape, J-shape, Bell-shape and Irregular-shape. Although the area showed good floral diversity and evenness, woody species including *Sterculea setigera*, *Boswellia papyrifera* and *Pterocarpus lucens* were the most critically hampered ones in their population status and hence research and/or development interventions have to be done to mitigate the problem the sooner possible.

Key words: Equitability, diversity, dryland, Metema woodland, population structure, regeneration.

Introduction

The available information on the forest resources of Ethiopia is very limited on location, extent and volume of the standing growing stock, annual growth rates and the depletion rate of the resources. The forests and woodlands have, however, been declining both in size

(deforestation) and quality (degradation) (EFAP, 1994). It is a common scenery that Ethiopia's indigenous forest trees and shrubs are dwindling at escalating rate as a result of high population pressure and its related consequences like the need for agricultural land, settlement, fuel wood, house construction, income generation, and for other so many needs and wants. Besides, absence of strong forest policy adding with the change in the climatic condition of the country made the problem worse, especially in the arid and semiarid regions of Ethiopia.

Four broad vegetation types can be distinguished for the arid and semiarid regions of Ethiopia (Friis, 1992). These are broad-leaved deciduous woodland, small-leaved deciduous woodland, lowland dry forest, and lowland semi-desert and desert vegetation. Increasing human pressure in recent years in the drylands is initiating the rapid advance of desertification. Furthermore, the effects of global climate change, which prevails in the dryland regions, are further intensifying problems in dry regions making them more arid, vulnerable and difficult for habitation (Akimaliev, 2005).

Metema area is one of such dryland areas of Ethiopia located in the Northwestern part of Amhara Regional State of the country. Like other dryland areas of the country, land degradation is rife in Metema area because of over exploitation of the woodlands and farming the fragile lands. Transgression of agriculture towards the natural woodland, burning and overgrazing resulted in the clearing of woodlands. This in turn accelerated soil erosion and destroyed the soil and floristic diversity of the area (Sisay Asfaw, 2006).

Several researches have been undertaken by several researchers (Sisay Asfaw, 2006) to address these problems of the area. However, most of these studies were focused on only woody species with a special emphasis on the production, population structure and soil seed bank and alternative land use options for frankincense producing species. Baseline information is lacking on the general plant diversity, composition, population structures and other ecological perspectives which profoundly could contribute to the formulation of development and management plan for plant species growing in the area. Therefore, this research activity was intended to address this research gap. The objective of the study was,

therefore, to study the plant species diversity, regeneration status and vegetation structure of the woodland vegetation of Metema area.

Materials and methods

The study area

The study was conducted in 2008 in the Metema district in North Gondar Zone of the Amhara National Regional State of Ethiopia. It is located at 36°17' E and 12° 39' N with an altitudinal range of 550 to 1608 meter above sea level (m a.s.l). According to the National Meteorological Agency of Ethiopia (2009), the annual rainfall of Metema ranges from 514.4 to 1128 mm with a mean annual rainfall of 924.2 mm. The mean monthly minimum and maximum temperature of Metema district are 19.31^oC and 35.65 ^oC, respectively. The mean annual temperature is 32.98 ^oC.

Data collection

Sampling design

A systematic sampling method was employed for the study. Quadrats of 25 m x 25 m (625 m²) were placed next to each other at the interval of 150 m to 200 m, following the homogeneity of the vegetation. Trees and shrubs were assessed in the main quadrat while seedling and sapling in two subquadrats of 2 m x 5 m laid at the beginning and the end of the baseline on opposite sides of the main quadrat. For the herbaceous species and soil sampling, a total of five subquadrats with the area of 1 m X 1 m were laid within each main quadrat in a way that four subquadrats at the corner and one at the center (Figure 1).

Vegetation data collection

All the plant species in all quadrats were recorded but the cover abundance of all the vascular plants in each quadrat were estimated using the visual judgment. Trees and shrubs, taller than 2 m and more than 2 cm in diameter were measured for height and diameter at breast height (DBH). Regeneration assessment was made through counting of each species in the two subquadrats of 2 m x 5 m. In all quadrats, additional trees and shrubs outside the quadrat boundaries within 10-15 m and field layer species were collected and noted as

present. The collected plant specimens with their vernacular names were taken to the National Herbarium of Addis Ababa University for identification. Then, specimens were dried and identified using authenticated specimens and referring to the published volumes of Flora of Ethiopia and Eritrea.

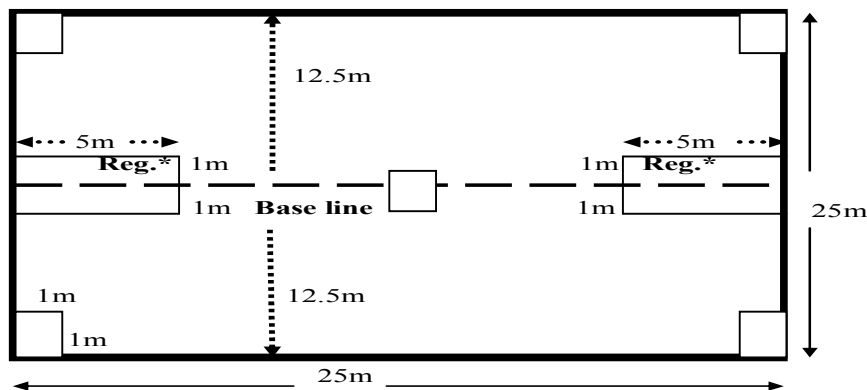

Note: Reg.*=regeneration assessment

Figure 2. Sampling design for the plant diversity, regeneration status and vegetation structure of the Woodland Vegetation.

Vegetation data analysis

Floristic composition

Species composition: Species richness is a biologically appropriate measure of alpha diversity and is usually expressed as number of species per sample unit (Whittaker, 1972). The number of species (species richness) was determined by summing up the number of species identified directly in the field and in the National Herbarium.

Plant diversity and equitability analysis

Shannon-Weiner diversity index was used to infer about the total Metema floristic diversity and evenness. For analysis, the cover-abundance value of each encountered species was used.

Structural data analysis

Importance Value Index (IVI) is an index computed from relative density, relative dominance and relative frequency, which describes the structural role of a species in a stand. It is useful for making comparisons among stands in reference to species composition and stand structure (Pichette and Gillespie, 1999). IVI permits a comparison of the ecological significance of species in a given forest type. IVI was calculated following Pichette and Gillespie (1999) formula.

Population Structure: Population structure of tree stem diameter distribution has been used to infer past disturbances, regeneration patterns and successional trends in tree populations (Demel Teketay, 1997; Tamrat Bekele, 1994). Height and diameter frequency distribution of all tree and shrub species were employed to determine population structure of the vegetation. Each species encountered in a quadrat were grouped into a diameter class of 4 cm and height of 2 m and structure of the species were depicted using frequency histogram of both diameter and height class distributions following Peters (1996).

Regeneration Status: The regeneration status of woody species was summarized based on the total count of seedling and sapling of each species across all quadrats and presented in tables and frequency histograms.

Results

Floristic Composition

A total of 87 vascular plant species were identified from 74 quadrates in the Metema woodland vegetation between the altitudinal ranges of 728 m and 932 m a.s.l. These species belonged to 36 families and 74 genera. The five dominant families occurring in the area were 16 (18.39%) species of Fabaceae in 13 genera, 9 (10.34%) species of Poaceae in 8 genera, 7 (8.05%) species of Combretaceae in 3 genera, 5 (5.75%) species of Acanthaceae in 5 genera and 5 (5.75%) species of Asteraceae in 5 genera.

With regard to the growth habits of the identified species, 42 (48.28%) species were herbs, 3 (3.45%) species were climbers, 3 (3.45%) species were shrubs, 13 (14.94%) species were shrub or trees and 26 (29.89%) species were trees.

Species diversity, richness and equitability

The Shannon diversity of the Metema vegetation was found to be 3.67 reflecting good diversity. The 87 species encountered in the area were distributed evenly with the Shannon evenness value of 0.82 and small dominance (0.04).

Vegetation Structure

Density, diameter and height of woody species

A total of 1743 individuals of woody plants (376.86 individuals per ha) were encountered from 74 studied quadrates (Table 1). The first six woody species with the highest density were *Sterculea setigera*, *Boswellia papyrifera*, *Anogeissus leiocarpa*, *Lannea fruticosa*, *Dichrostachys cinerea*, and *Pterocarpus lucens*. The cumulative diameter class distribution pattern was broken reverse J-shape, which revealed that there was a very high decrease in density of the second diameter class. Generally, the density of woody individuals decreased with increasing diameter classes. However, 56% of the total individuals were restricted between the first and fourth classes of diameter whereas, about 30% and 14% of the density were found to be in the middle diameter classes (between fifth and eighth) and in the higher diameter classes (between ninth and twelfth), respectively (Figure 2). Similarly, the density distribution of woody individuals in different height classes showed decrease in density with increasing height classes (Figure 3) and yet there was a very high decrease in density of class two, three, four and five diameter classes.

Table 8. Importance value indices for woody species.

Species	Density(No. individuals/ha)	Relative Density (%)	Relative Frequency (%)	Relative Basal Area (%)	IVI (%)	IVI Rank
<i>Acacia polyacantha</i>	8.22	2.18	2.41	0.15	4.74	19
<i>Acacia seyal</i>	6.05	1.61	1.77	0.60	2.53	24
<i>Acacia sieberiana</i>	3.68	0.98	1.27	0.49	2.73	23
<i>Albizia lophantha</i>	4.76	1.26	1.77	1.60	4.63	20
<i>Albizia melanoxydon</i>	0.43	0.11	0.25	0.33	0.69	33
Anogeissus leiocarpa	38.49	10.21	6.71	16.13	23.86	3
<i>Balanites aegyptiaca</i>	2.16	0.57	1.14	0.16	1.87	28
<i>Boscia mossambicensis</i>	0.43	0.11	0.25	0.00	0.36	37
Boswellia papyrifera	52.76	14	7.22	19.08	40.28	2
<i>Boswellia pirottae</i>	2.16	0.57	0.76	1.07	2.40	25
<i>Bridelia micrantha</i>	0.86	0.23	0.51	0.00	0.74	32
<i>Calotropis procera</i>	0.65	0.17	0.25	0.00	0.42	36
Combretum adenogonium	9.51	2.52	4.81	1.31	8.64	9
Combretum collinum	13.41	3.56	4.43	2.60	10.58	6
<i>Combretum hartmannianum</i>	0.43	0.11	0.25	0.07	0.43	35
<i>Combretum molle</i>	9.30	2.47	2.53	0.60	5.59	17
Combretum sp.	8.43	2.24	3.92	1.45	7.60	10
<i>Dalbergia melanoxydon</i>	12.76	3.38	3.67	0.39	7.44	11
Dichrostachys cinerea	22.27	5.91	4.3	0.19	10.39	7
<i>Diospyros abyssinica</i>	1.08	0.29	0.38	1.64	2.31	26
<i>Ficus sycamoros</i>	1.30	0.34	0.76	0.00	1.10	31
<i>Ficus thonningii</i>	1.08	0.29	0.63	0.66	1.58	29
<i>Flueggea virosa</i>	14.27	3.79	2.41	0.00	6.19	16
<i>Gardenia ternifolia</i>	6.49	1.72	1.9	0.00	3.62	22
<i>Grewia bicolor</i>	1.30	0.34	0.76	0.16	1.26	30
Lannea fruticosa	29.84	7.92	8.23	7.03	23.17	4
<i>Lonchocarpus laxiflorus</i>	0.65	0.17	0.25	0.06	0.48	34
<i>Maytenus senegalensis</i>	0.22	0.06	0.13	0.00	0.19	39
<i>Maytenus undata</i>	12.97	3.44	3.29	0.54	7.27	12
<i>Ochna leucophloeos</i>	12.11	3.21	3.04	0.07	6.32	15
<i>Piliostigma thonningii</i>	0.22	0.06	0.13	0.10	0.29	38
Pterocarpus lucens	17.73	4.7	5.95	8.90	19.55	5
Sterculia setigera	27.24	7.23	6.71	30.53	44.46	1
Stereospermum kunthianum	15.78	4.19	4.68	0.27	9.13	8
<i>Strychnos innocua</i>	13.19	3.5	2	0.92	6.42	14
<i>Tamarindus indica</i>	0.22	0.06	0.13	0.00	0.19	39
<i>Terminalia laxiflora</i>	6.27	1.66	3.04	2.48	7.18	13
<i>Ximenia americana</i>	6.27	1.66	2.66	0.18	4.50	21
<i>Ziziphus abyssinica</i>	8.65	2.29	2.91	0.16	5.36	18
<i>Ziziphus spina-christi</i>	3.24	0.86	1.14	0.06	2.06	27
Total	376.86	100	100	100.00	300.00	

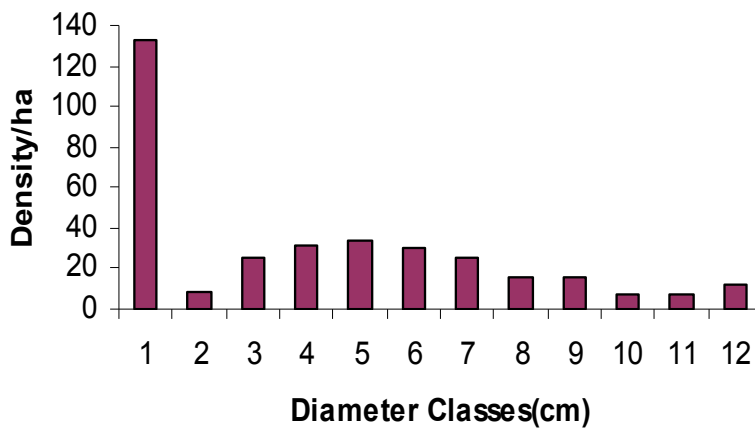

Figure 3. Cumulative diameter class frequency distribution of woody species.

Diameter class: 1= 0-4cm, 2 = 4-8cm, 3 = 8-12 cm, 4 = 12-16 cm, 5 = 16-20 cm, 6 = 20-24 cm, 7 = 24-28 cm, 8 = 28-32 cm, 9 = 32-36 cm, 10 = 36-40 cm, 11 = 40-44 cm, and 12 = >44 cm.

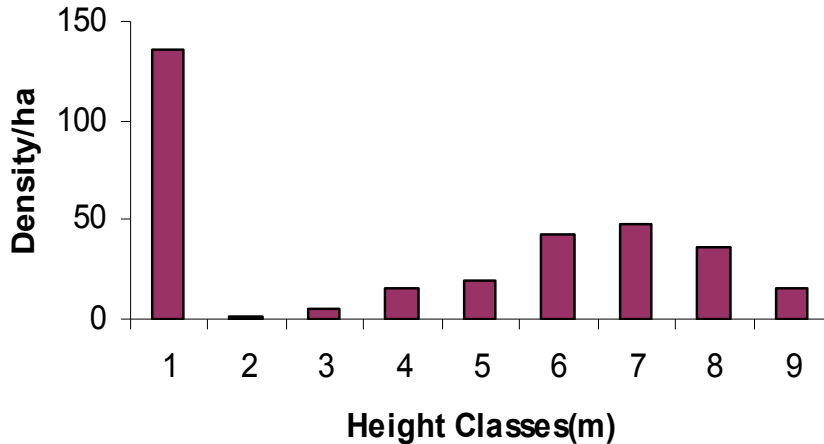

Figure 4. Cumulative height class frequency distribution of woody species.

Height class: 1 = 0-2 m, 2 = 2-4 m, 3 = 4-6 m, 4 = 6-8 m, 5 = 8-10 m, 6 = 10-12 m, 7 = 12-14 m, 8 = 14-16 m and 9 = >16 m.

Basal area and importance value index (IVI)

The basal area of all woody species was 42.54 m² ha⁻¹. The following species made the largest contribution to the basal area: *Sterculea setigera* (30.53%), *Boswellia papyrifera* (19.08%), *Anogeissus leiocarpa* (16.13%), *Pterocarpus lucens* (8.9%), *Lannea fruticosa* (7.03%), *Combretum collinum* (2.6%) and *Terminalia laxiflora* (2.48%) but the other remaining species contributed to only 13.25% (Table 1).

The nine most important woody species with the highest IVI and contributed to over 63% of the total IVI in decreasing order were *Sterculea setigera* (44.46%), *Boswellia papyrifera* (40.28%), *Anogeissus leiocarpa* (23.86%), *Lannea fruticosa* (23.17%), *Pterocarpus lucens* (19.55%), *Combretum collinum* (10.58%), *Dichrostachys cinerea* (10.39), *Stereospermum kunthianum* (9.13%), and *Cobretum adenogonium* (8.64%). Whereas, *Piliostigma thonningii*, *Tamarindus indica*, *Maytenus senegalensis*, and others have a small contribution to the total IVI (Table 1).

Population structure of woody species

The population structure of selected species from the Metema woodland vegetation fell into one of four general diameter class distribution patterns. These are: 1) interrupted Inverted-

J-shape, which seemed to show a pattern where species frequency distribution had the highest frequency in the lower diameter classes and a gradual decrease towards the higher classes, still, showing either a complete absent or a very high decrease in density somewhere in the lower classes or middle classes. 2) J-shape, which showed a type of frequency distribution in which there was a low number of individuals in the lower diameter classes but increased towards the higher diameter classes. 3) Bell-shape, which showed a type of frequency distribution in which a number of individuals in the middle classes were high and decreased towards the lower and higher diameter classes. 4) Irregular-shape, which seemed a bell-shape distribution pattern but a complete absent of individuals in class two and three and a fair representation of individuals in class one. These patterns were illustrated by the six dominant species that had been selected based on their importance value indices. Accordingly, *Anogeissus leiocarpa*, *Combretum collinum* and *Lannea fruticosa* were depicted an interrupted Inverted-J-shape pattern (Figure 4(b), (c) and (e)). *Sterculea setigera* (Figure 4(a)) depicted a J-shape pattern, while *Boswellia papyrifera* and *Pterocarpus lucens* (Figure 4(d) and (f)) fell in the bell-shape and irregular-shape patterns, respectively.

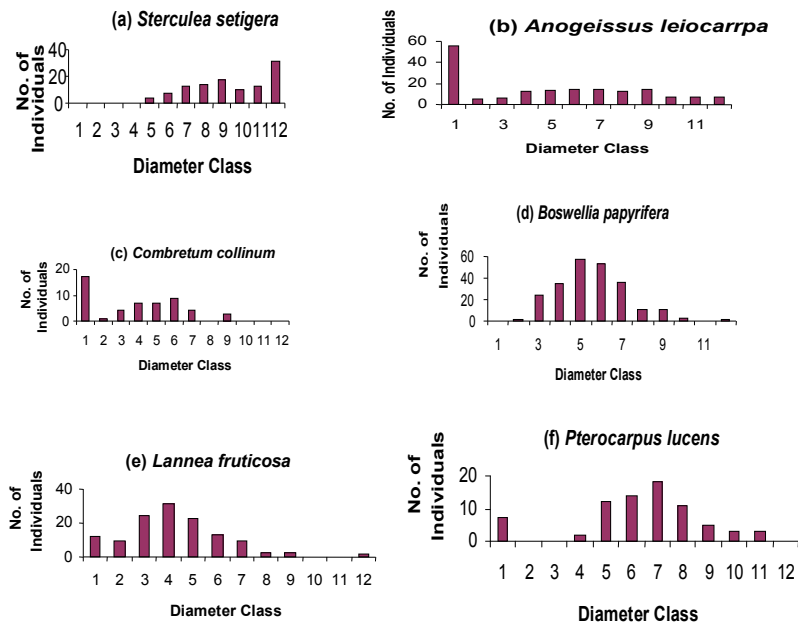

Figure 5. Diameter class frequency distribution of selected tree species.

Diameter class: 1= 0-4cm, 2 = 4-8cm, 3 = 8-12 cm, 4 = 12-16 cm, 5 = 16-20 cm, 6 = 20-24 cm, 7 = 24-28 cm, 8 = 28-32 cm, 9 = 32-36 cm, 10 = 36-40 cm, 11 = 40-44 cm, and 12 = >44 cm.

On the other hand, the patterns of height class distribution fell into three categories. These were: 1) interrupted inverted-J-shape, which seemed to show a pattern where species frequency distribution had the highest frequency in the lower height classes and a gradual decrease towards the higher classes, still showing either a complete absent or a very high decrease in density somewhere in the lower classes or middle classes, 2) J-shape, which showed a type of frequency distribution in which there was a low number of individuals in the lower height classes but increased towards the higher height classes, 3) nearly bell-shape, which showed a type of frequency distribution in which a number of individuals in the middle classes were high, and decreased towards the lower and higher height classes, 4) Irregular-shape, which generally seemed a broken J-shape distribution pattern where there is increase in density of individuals only limited in and towards higher height classes but still showing a very high decrease in density in class eight and nine. Accordingly, *Boswellia papyrifera* (Figure 5 (d)) depicted a J-shape pattern while *Anogeissus leiocarpa* and *Combretum collinum* (Figure 5(b) and (c)) fell in interrupted inverted-J-shape pattern. *Lannea fruticosa* (Figure 5(e)) showed nearly bell-shape distribution pattern. *Sterculea setigera* and *Pterocarpus lucens* (Figure 5 (a) and (f)) revealed an Irregular-shape.

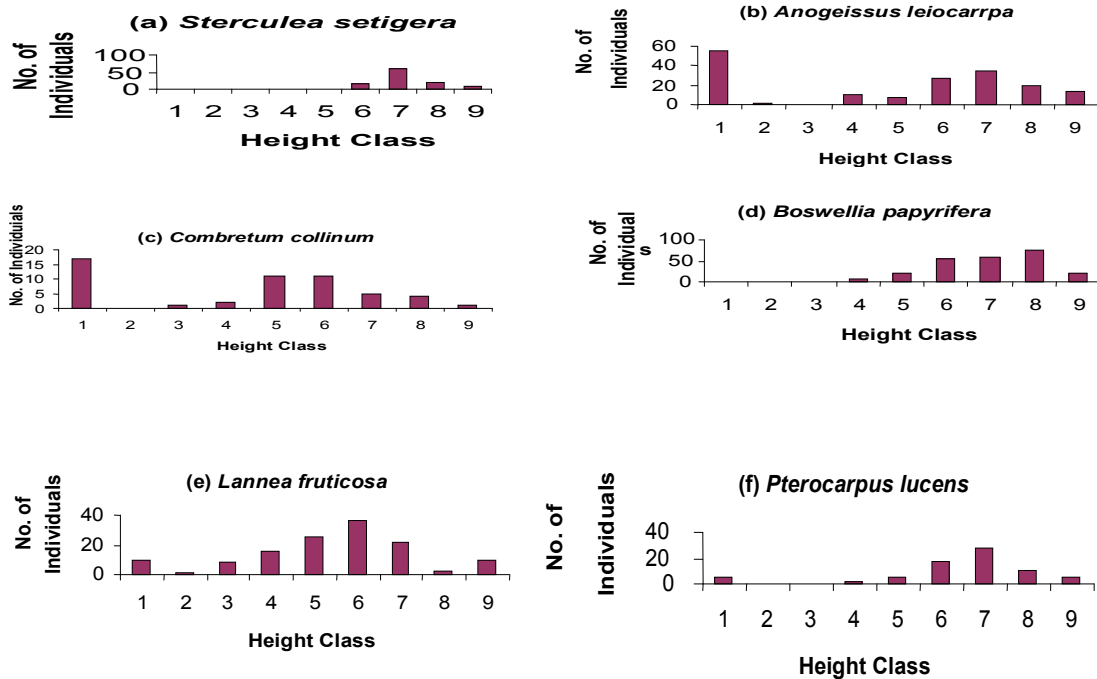

Figure 6. Height class frequency distribution of selected tree species. Height class: (1 = 0 - 2 m; 2 = 2 - 4 m; 3 = 4 - 6 m; 4 = 6 - 8 m; 5 = 8 - 10 m; 6 = 10 - 12 m; 7 = 12 - 14 m; 8 = 14 - 16 m and 9 = ≥ 16 m).

Regeneration status

A total of 556 individual seedlings (120 individuals ha⁻¹) belonging to 26 species were counted from all quadrates, while a total of 86 individual saplings (14 individuals ha⁻¹) were counted for 19 species. Accordingly, the following species made the largest contribution to the seedling counts per hectare: *Dichrostachys cinerea* (18.81), *Flueggea virosa* (13.84), *Stereospermum kunthianum* (11.24), *Anogeissus leiocarrpa* (10.38), and *Ochna leucophloeos* (11.46). On the other hand, *Dichrostachys cinerea* (5.19), *Anogeissus leiocarrpa* (1.73), *Acacia polyacantha* (1.73), *Dalbergia melanoxylon* (1.51) and *Stereospermum kunthianum* (1.30) contributed the largest proportion of sapling counts. Generally, *Dichrostachys cinerea*, *Anogeissus leiocarrpa*, *Ochna leucophloeos*, *Acacia polyacantha*, *Dalbergia melanoxylon* and *Stereospermum kunthianum* were found to be good in recruitment status relative to other species.

Discussions

Floristic composition

Floristic composition of a given vegetation can be described in terms of its richness in species, abundance, dominance, and frequency (Lamprecht, 1989). In this study, a total of 87 species including climbers, herbs, shrubs and tree were encountered in the Metema woodland vegetation. Out of all the species, *Smithia abyssinica* and *Boswellia pirottae* were found to be endemic to Ethiopia. However, *Boswellia pirottae* was found to be one of the endemic plant species of Ethiopia which is endangered (Ensermu Kelbessa, 1992). The diversity and evenness of the Metema woodland vegetation using Shannon-Weiner diversity index were found to be 3.67 and 0.82, respectively. According to Kent and Coker (1992), the Shannon-Weiner diversity index normally varies between 1.5 and 3.5 and rarely exceeds 4.5. The low Shannon evenness is an indication of the existence of unbalanced distribution of the individuals of species encountered at a given study area. However, the study result showed the area is with good diversity and more or less even representation of individuals of all species was encountered in the studied quadrates.

Population structure

Species-abundance measures are ways of expressing not only the relative richness but also evenness and thereby assessing diversity (Barnes *et al.*, 1998). In this study, a total of 376.86 individuals ha⁻¹ of woody plants were encountered from all quadrates. *Sterculea setigera*, *Boswellia papyrifera*, *Anogeissus leiocarrpa*, *Lannea fruticosa*, *Dichrostachys cinerea* and *Pterocarpus lucens* were the most abundant species while species like *Albizia melanoxyton*, *Combretum hartmannianum*, *Boscia mossambicensis*, *Piliostigma thonningii*, *Tamarindus indica*, and *Maytenus senegalensis* were poorly reckoned in this regard. Generally speaking, only few species were dominating the woodland in their abundance while many of the species were very rare or low in their abundance. The result reflects either adverse environmental situations or random distribution of available resource in the woodland (Miranda *et al.*, 2002 as cited by Feyera Senbeta *et al.*, 2007). It can be further inferred that the woody plants were distributed in uneven manner may be due to inability of individuals to cope up harsh environmental condition (e.g. high temperature, low rainfall regime), human disturbance, livestock trampling and grazing, and other biotic and abiotic impairments in the area.

Basal area provides the measure of the relative importance of the species than simple stem count. Species with largest contribution in dominance value could be considered as the most important species in the study vegetation. Otherwise, in most cases shrubs could be the dominant species if only we consider density as a measure to indicate the overall dominance of the species (Adefires Worku, 1992 and 2006; Simon Shibru and Girma Balcha, 2004). In this study, basal area analysis across individual species revealed that there was high domination by very few species. *Sterculea setigera* was the dominant species followed by other species like *Boswellia papyrifera*, *Anogeissus leiocarrpa*, *Pterocarpus lucens*, *Lannea fruticosa*, *Combretum collinum* and *Terminalia laxiflora*. The remaining species in total contributed little relative basal area. This implies that just the above mentioned seven species are the most ecologically important woody species in Metema.

Frequency reflects the pattern of distribution and gives an approximate indication of the heterogeneity of a stand (Lamprecht, 1989; Haileab Zegeye *et al.*, 2006). The results of frequency showed that there was relatively fair presence of certain species in most of quadrates. The highest relative frequency was scored by *Lannea fruticosa*, which was relatively low as compared to the highest relative density and the highest relative basal area scored by *Boswellia papyrifera* and *Sterculea setigera*, respectively. This implied that due to the fact that scores of frequency were shared among species, the highest frequency became low. In other words, it can be concluded that there were fair presence of many species in most of the quadrates. These might be due to the fact that these species might have a wide range of seed dispersal mechanisms like by wind, livestock, wild animal, birds and the like. According to Lamprecht (1989), stands that yield more or less the same IVI for the characteristic species indicate the existence of the same or at least similar stand composition and structure, site requirements and comparable dynamics among species. In contrary to this, almost all species in this study showed variation in terms of IVI, showing different ecological importance of each species in the woodland.

Information on the population structure of a tree species indicates the history of the past disturbance to that species and the environment and hence, used to forecast the future trend of the population of that particular species (Tamrat Bekele, 1994; Demel Teketay, 1997). In this study, it revealed that the cumulative diameter class frequency distribution of woody individuals in an interrupted reverse-J-shape pattern, there was a very high decrease in density of diameter class two. However, the analysis of selected species fell in four different patterns i.e. interrupted J-shape, bell-shape, irregular-shape and J-shape. According to previous studies (Silvertown, 1982; Silvertown and Doust, 1993; Mekuria *et al.*, 1999; Alemnew Alelign, 2001; Alemayehu Wassie, 2002; Getachew Tesfaye *et al.*, 2002), a reverse J-shape distribution pattern was considered as an indication of stable population status or good regeneration status. In this study, however, both cumulative diameter class distribution of individual woody plants and selected species resulted in patterns showing a hampered regeneration profiles. The cumulative one showed nearly reverse J-shape with a very high decrease in density at the second diameter class, reflecting the hampered regeneration profiles in the area. This tells that there had been a selective

removal of small diameter class individuals either by local dwellers for some purpose (e.g. for fencing and fuel wood), or by livestock (trampling or browsing), or might be other biotic impairments like termite attack. In most cases, this diameter class is the most susceptible and palatable age of individuals and this might be the reason that made individuals unable to cope up with any disturbance encountered. Similarly, *Anogeissus leiocarpa*, *Combretum collinum* and *Lannea fruticosa* were depicted in an interrupted reverse-J-shape. *Anogeissus leiocarpa* and *Combretum collinum* revealed a very high decrease in density at diameter class two and three, while *Lannea Fruticosa* in density of the diameter class one and two. *Boswellia papyrifera* was depicted in bell-shape pattern that is the reflection of a discontinuous or irregular recruitment. This species is one of the most economically important species in producing frankincense to the local farmers. It was hardly common to see untapped stems of *Boswellia papyrifera* in the studied quadrates. This might be one of the most important reasons that made the species retard from its normal recruitment status. *Sterculea setigera* fell in J-shape distribution pattern, which is considered as reflection of severe limitation on the regeneration for some reason (Peters, 1996). This study noted that *Sterculea setigera* was one of the most important multipurpose tree species used for like fodder especially during the dry season at times when there is forage scarcity. This study also noted that the peels of this species used as chewing gum by local kids. Moreover, some termite dunes piled under this tree and felled logs. *Pterocarpus lucens* also showed an irregular-shape with complete absent of individuals in diameter class two and three. This also reflects a hampered regeneration status of the species due to possible reasons like human disturbance, livestock trampling or browsing, and some other biotic and abiotic impairment in the area.

Similarly, the pattern of the cumulative height class distribution of all woody species showed interrupted reverse J-shape like the pattern revealed by the cumulative diameter class distribution. A reverse-J-shape height class distribution pattern was considered as a normal type of distribution indicating continuous or good regeneration revealed by stable population (Getachew Tesfaye and Abiyot Berhanu, 2006; Feyera Senbeta *et al.*, 2007). However, both the cumulative and selected species analysis of this study depicted in different patterns that reflect the hampered regeneration profile. Accordingly, *Anogeissus*

leiocarrpa and *Combretum collinum* revealed an interrupted J-shape while *Lannea fruticosa* in bell-shape pattern. *Sterculea setigera* and *Pterocarpus lucens* fell in irregular-shape while *Boswellia papyrifera* in J-shape. This might be due to similar reasons for diameter class distribution. Generally, only *Anogeissus leiocarrpa* and *Combretum collinum* were similar in both diameter class and height class distribution, showing an interrupted J-shape. The other species showed a higher density shift towards the middle and higher height classes than showed in diameter class distribution. This is evident that species are to be different in their density distribution patterns across height and diameter classes.

Conclusions and Recommendations

The study in the broad-leaved deciduous woodland of Metema revealed that Metema has high floristic composition and diversity with good distribution. The study came across 42 herbs, 42 woody species and 3 climbers. However, the results of woody species revealed that only few species scored high density and basal area. Both the cumulative diameter and height class frequency distribution patterns of woody individuals resulted in an interrupted inverted-J-shape, which is the reflection of a more or less poor regeneration profile in the area. Similarly, the population structure of the six selected important species showed that all were in poor regeneration status, though the degree of the problem varies from species to species. *Sterculea setigera* was the most critically hampered species followed by *Boswellia papyrifera* and *Pterocarpus lucens*.

Based on the results it was recommended that urgent research and/or development action should be considered to circumvent and address the problems faced, especially on those species poorly scored and reckoned in their regeneration status and importance value index for instance, *Sterculea setigera*, *Boswellia papyrifera*, *Pterocarpus lucens*, *Boswellia pirottae*, *Tamarindus indica*, and *Terminalia laxiflora*. Research on seed viability of the problematic species, their seed raining mechanisms and problems, their seedling establishment mechanisms and problems, soil seed bank analysis and other possible ways to identify specific problems of the species that made them unable to regenerate should be done.

Devising environmentally-friendly strategy for effective scaling up of products and productivity of those economically important tree species growing in the area such as *Boswellia papyrifera* and *Boswellia pirottae* should be given attention, so that this in turn will contribute to the conservation and development of other floral species in the area. Finally, further research has to be done to fill gaps of this research, especially investigation in the area of socio-economic and ethnobotanical perspectives should be considered.

References

- Adefires Worku. 2006. Population Status and Socio-economic Importance of Gum and Resin Bearing Species in Borana Lowlands, southern Ethiopia. MSc. Thesis. Addis Ababa University, Department of Biology, Addis Ababa.
- Akimaliev, J. 2005. Soil Degradation in Kyrgyzstan and Measures of Soil Improvement. In: El-Beltagy, A. and Saxena, M. C. (Eds.). Sustainable Development and Management of Drylands in the Twenty-first Century. Proceedings of the Seventh International Conference on the Development of Drylands, 14-17 September 2003, Tehran, Iran. ICARDA, Aleppo, Syria. Xvi+ 63pp.
- Alemayehu Wassie. 2002. Opportunities, constraints and prospects of the Ethiopian Orthodox Tewahido Churches in conserving forest resources: the case of churches in South Gondar, northern Ethiopia. MSc. Thesis, Swedish University of Agricultural Sciences.
- Alemnew Aleligne. 2001. Diversity and socio-economic importance of woody plants on the peninsula of Zegie, northwestern Ethiopia. M.Sc. Thesis, Swedish University of Agricultural Sciences.
- Barnes, B.V., Zak, D.R., Denton, S.R., Spurr, S.H. 1998. Forest Ecology, fourth edition. Wiley, New York.
- Demel Teketay. 1997. Seedling population and regeneration of woody species in dry Afromontane forests of Ethiopia. *Forest Ecology and Management* **98**: 149-165.
- EFAP (Ethiopian Forestry Action Program). 1994. Ethiopian Forestry Action Program, Vol. 2. The Challenge for Development. Ministry of Natural Resources Development and Environmental Protection, Addis Ababa.

- Ensermu Kelbessa, Sebsebe Demissew, Zerihun Woldu and Edwards, S. 1992. Some threatened Endemic plants of Ethiopia. NAPRECA Monograph, Series 2: 35-55.
- Feyera Senbeta, Tadesse Woldemariam, Sebsebe Demissew and Manfred Denich. 2007. Floristic Diversity and Composition of Sheko Forest, Southwest Ethiopia. *Ethiopian Journal of Biological Sciences* 6(1): 11-42. Addis Ababa, Ethiopia.
- Friis, I. 1992. Forests and Forest Trees of Northeast Tropical Africa, HMSO Kew Bulletin Additional Series 15, London. 396 pp.
- Getachew Tesfaye and Abiyot Berhanu. 2006. Regeneration of Indigenous Woody Species in the Understory of Exotic Tree Species Plantation in Southwestern Ethiopia. *Ethiopian Journal of Biological Sciences* 6(1): 31-43.
- Getachew Tesfaye, Demel Teketay, Masresha Fetene. 2002. Regeneration of fourteen tree species in Harena forest, southeastern Ethiopia. *Flora* 197: 461–474.
- Haileab Zegeye, Demel Teketay, and Ensermu Kelbessa. 2006. Diversity, regeneration status and socio-economic importance of the vegetation in the islands of Lake Ziway, south-central Ethiopia. *Flora* 201: 483–498.
- Kent, M. and Coker, P. 1992. Vegetation Description and Analysis: A practical approach. Belhaven Press, London.
- Lamprecht, H. 1989. Silviculture in Tropics. Tropical forest ecosystems and their tree species:-Possibilities and methods for their long-term utilization. Institute of Silviculture, University of Gottingen. Technical Cooperation of Federal Republic of Germany, Berlin, Pp. 296.
- Mekuria A., Demel Teketay and Olsson, M. 1999. Soil seed flora, germination and regeneration pattern of woody species in an Acacia woodland of Rift Valley in Ethiopia. *Journal of Arid Environments* 43: 411- 435.
- Peters, C.M. 1996. The ecology and management of Non-timber forest resources. World Bank Technical paper 322, Washington.
- Pichette, P. R. and Gillespie, L. 1999. Terrestrial Vegetation Biodiversity Monitoring Protocols. Ecological Monitoring and Assessment Network Occasional Paper Series. Report No. 9. Burlington, Ontario, Canada. 123-124pp.
- Silvertown, J.W., 1982. Introduction to Plant Population Ecology. Longman, London.

- Silvertown, J.W., Doust, J.L. 1993. Introduction to Plant Population Biology. Blackwell, Oxford.
- Simon Shibru and Girma Balcha. 2004. Composition, structure and regeneration status of woody species in Dindin natural forest, southeast Ethiopia: An Implication for conservation. *Ethiopian Journal of Biological science*. 3(1): 31-48. Addis Ababa.
- Sisay Asfaw. 2006. Effects of Fire and Grazing on Woody Species Composition, Population Structure, Soil Seed Banks and Soil Carbon in Woodlands of North Western Ethiopia. MSc. Thesis. BOKU University, Vienna.
- Tamrat Bekele. 1994. Studies on Remnant Afromontane Forests on the Central Plateau of Shewa, Ethiopia. PhD Dissertation, Uppsala University, Uppsala, Sweden.
- Whittaker, R.H. 1972. Evolution and measurement of species diversity. *Forest Ecology and Management*. 186 (2003) 61–71.

**Plant community and ecological analysis of the woodland vegetation in Metema area,
Amhara National Regional State, Northwestern Ethiopia**

Haile Adamu¹, Tamrat Bekele², Gemedo Dalle³

¹Sekota Dryland Agricultural Research Center, P.O.Box 62, Sekota, Ethiopia.

Email:mamnaturepal@yahoo.com

²Addis Ababa University, Faculty of Life Sciences, P.O.Box 1176, Addis Ababa, Ethiopia.

³Institute of Biodiversity Conservation, P.O.Box 80119, Addis Ababa, Ethiopia.

Abstract

The study was conducted in 2008 in the broad-leaved deciduous woodland of Metema in northwestern part of Amhara regional state, Ethiopia to determine plant community types and species distribution patterns and their relationship with different environmental variables. A selective approach with a systematic sampling design was used. A total of 74 quadrates, each with the size of 25 m x 25 m at an interval of 150 m to 200 m were laid along the established transect lines, following the homogeneity of the vegetation. For herbaceous and soil data collection, five subquadrats each with the size of 1 m x 1 m were established at four corners and center of every quadrate. Results showed that three community types were identified using TWINSpan analysis and all the three community types showed good diversity in Shannon-Weiner index, the highest record by community type II. The highest similarity coefficient of 0.49 (49%) in species richness was recorded between community type II and III. Results also indicated that these community types were completely different from community types so far discovered in other dryland parts of the country. The canonical correspondence ordination diagram revealed that the distribution pattern of community type I was highly explained by moisture, while that of community type III and II by electrical conductivity and altitude and moisture, respectively. Altitude was the most statistically significant environmental variable followed by moisture and electrical conductivity in determining the total variation in species composition and distribution patterns while pH and cation exchange capacity had non significant effect. In conclusion, it is recommended that any intervention should take into account the three community types and their environmental settings to make the intervention more feasible.

Key words: Diversity, dryland, environmental variables, ordination, Metema woodland, plant community.

Introduction

Four broad vegetation types can be distinguished for the arid and semiarid regions of Ethiopia (Friis, 1992). These are broad-leaved deciduous woodland, small-leaved deciduous woodland, lowland dry forest and lowland semi-desert and desert vegetation. Increasing human pressure in recent years in the dryland is initiating the rapid advance of desertification. Furthermore, the effects of global climate change which prevails in the dryland regions has further intensified problems in dry regions making them more arid, vulnerable and difficult for habitation (Akimaliev, 2005).

Metema area is one of such dryland parts of Ethiopia located in the Northwestern part of Amhara Regional State. Like other dryland parts of the country, land degradation is rife in Metema area because of over exploitation of the woodlands and farming of the fragile lands. Transgression of agriculture towards the natural woodland, burning and overgrazing resulted in the clearing of woodlands. This in turn accelerated soil erosion and destroyed the soil and floristic diversity of the area (Sisay Asfaw, 2006). To address these problems, some research activities have been undertaken by several researchers (Sisay Asfaw, 2006). Nevertheless, most of these studies were focused only on woody species with a special emphasis on the production, population structure and soil seed bank and alternative land use options for frankincense producing species. Baseline information is lacking on the general plant diversity, plant community and other ecological perspectives which profoundly could contribute to the formulation of development and management plan for plant species growing in the area. Therefore, this research activity was intended to address this research gap. The objective of the study was, therefore, to assess plant communities and ecology of the woodland vegetation in Metema area.

Materials and methods

The study area

The study was conducted in 2008 in the Metema district in North Gondar Zone of the Amhara National Regional State of Ethiopia. It is located at 36°17' E and 12° 39' N with an

altitudinal range of 550 to 1608 meter above sea level (m a.s.l). According to the National Meteorological Agency of Ethiopia (2009), the annual rainfall of Metema ranges from 514.4 to 1128 mm with a mean annual rainfall of 924.2 mm. The mean monthly minimum and maximum temperature of Metema district are 19.31^oC and 35.65 ^oC, respectively. The mean annual temperature is 32.98 ^oC.

Data collection

Sampling design

A systematic sampling method was employed for the study. Quadrates of 25 m x 25 m (625 m²) were placed next to each other at the interval of 150 m to 200 m, following the homogeneity of the vegetation. Trees and shrubs were assessed in the main quadrat while seedling and sapling in two subquadrats of 2 m x 5 m laid at the beginning and the end of the baseline on opposite sides of the main quadrat. For the herbaceous species and soil sampling, a total of five sub quadrates with the area of 1 m X 1 m were laid within each main quadrat in a way that four subquadrats at the corner and one at the center (Figure 1).

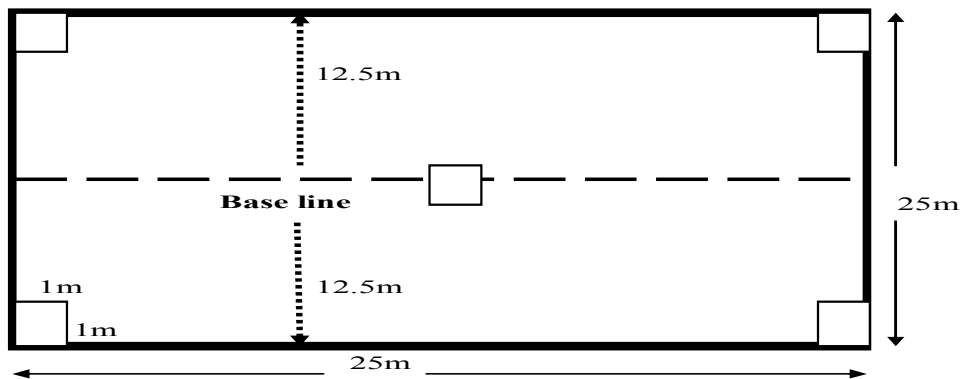

Figure 7. Sampling design for the plant community and ecological study of the woodland vegetation.

Vegetation data collection

All the plant species in all quadrates were recorded but the cover abundance of all the vascular plants in each quadrat were estimated using the visual judgment. Trees and shrubs, taller than 2 m and more than 2 cm in diameter were measured for height and diameter at breast height (DBH). Regeneration assessment was made through counting of

each species in the two subquadrats of 2 m x 5 m. In all quadrates, additional trees and shrubs outside the quadrate boundaries within 10-15 m and field layer species were collected and noted as present. The collected plant specimens with their vernacular names were taken to the National Herbarium of Addis Ababa University for identification. Then, specimens were dried and identified using authenticated specimens and referring to the published volumes of Flora of Ethiopia and Eritrea.

Environmental data collection

Environmental variables including altitude, geo-reference points (Northing and Easting) were recorded and soil samples were collected from each quadrate. Location and altitude of each quadrate were measured using Geographical Positioning System (GPS). Soil samples from each five subquadrate were sampled at a soil depth of 0-15 cm. The soil samples from the five subquadrats were pooled (up to the weight of 0.7-1kg) for each main quadrate and analyzed for soil pH, electrical conductivity, cation exchange capacity (CEC) and moisture.

Vegetation data analysis

Floristic composition

Species composition: Species richness is a biologically appropriate measure of alpha diversity and is usually expressed as number of species per sample unit (Whittaker, 1972). The number of species (species richness) was determined by summing up the number of species identified directly in the field and in the National Herbarium.

Plant diversity and equitability analysis

Shannon-Weiner diversity index was used to infer about the total Metema floristic diversity and evenness. For analysis, the cover-abundance value of each encountered species was used.

Multivariate analysis

Classification analysis

The vegetation data matrix was analyzed and classified using the computer program TWINSpan (Two-way INdicator SPecies Analysis) for Windows version 2.3 (Hill and

Šmilauer, 2005). TWINSPAN is a computer program designed primarily for ecologists and vegetation scientists who have collected data on the occurrence of a set of species in a set of samples. The samples may be stands, quadrates, or whatever is needed to the study. The program first constructs a classification of the samples, and then uses this classification to obtain a classification of the species according to their ecological preferences. The two classifications are then used together to obtain an ordered two-way table that expresses the species' synecological relations as concisely and clearly as possible (Hill and Šmilauer, 2005).

To analyze with this program, the percentage canopy cover-abundance value of all vascular plant species that had been rated based on 1-9 scale of Braun-Blanquet was further converted into Canoco condensed format using WCanoImp Help File (Šmilauer, 2002b) which is a subprogram in Canoco for Windows version 4.5 (Ter Braak and Šmilauer, 2002). With condensed data entry, a large number of zero entries that make the data entry and checking prone to error were reduced. It is only those species present in a quadrate or sample that are entered, each as a couplet with a number for each species followed by its abundance score (Kent and Coker, 1992; Hill and Šmilauer, 2005).

After identifying the community types from the Ordered two-way tables of WinTWINS output, the distinguished community types were further refined in a synoptic table where each column represents a community type. These synoptic values were made by the product of the species' frequency and average cover-abundance values following Tamrat Bekele (1993). Finally, the types were named after three of dominant and/ or characteristic species.

Similarity, diversity and equitability

Diversity and Equitability: To compare the diversity and equitability between the derived community types, Shannon-Weiner diversity and evenness indices were used by using the cover-abundance value of each species encountered. Furthermore, the diversity curves were made to compare species richness and species diversity pattern between the derived

community types following Gotelli and Colwell (2001). These diversity curves analysis were done using the analysis package in PAST version 1.62 (Hammer *et al.*, 2001).

Similarity index: The Sorensen similarity coefficient was used to compare similarity between the community types in their species richness. According to Kent and Coker (1992), the index is widely used because it gives more weight to the species that are common to the samples rather than to those that only occur in either sample. Accordingly, Sorensen coefficient of similarity (S_s) was calculated using the formula:

$$S_s = \frac{2a}{2a + b + c}$$

Where, S_s = Sorensen similarity coefficient, a = number of species common to both samples, b = number of species in sample, and c = number of species in sample 2.

Ordination analysis

Canocial Correspondence Analysis (CCA) was employed to do ordination. CCA is a technique which reveals the linear combinations of environmental variables explaining most of the variation in the species scores along the ordination axes. CCA is sometimes considered as a direct gradient analysis because it is based on the variation in the environmental data included. However, at the same time it is an indirect method because the variation in the species occurrences is used (Kent and Coker, 1992; Tamrat Bekele, 1993). The biplot, species/environment CCA was performed with the procedures in the computer program package of CANOCO version for 4.5 (Ter Braak, 2002). All the species cover-abundance values and environmental data were used in this analysis. The species data that has been rated based on 1-9 scale of Braun-Blanquet (as modified by Van der Maarel, 1979) was converted into condensed format before analysis using WCanoImp Help File (Šmilauer, 2002b), which is the subprogram in the CANOCO for Windows version 4.5 (Ter Braak and Šmilauer, 2002). The resulted ordination diagram was further analyzed to see the distribution pattern of the derived community types using CanoDraw for windows version 4.0 (Šmilauer, 2002a), which is also the subprogram in the CANOCO for Windows version 4.5.

The statistical significance of the canonical axis in explaining species/environment data was made for the first axis and all canonical axes using the Monte-Carlo permutation tests. Permutations test “under reduced model” was used following Lepš and Šmilauer (1999 and 2003) as used by Gemedo Dalle (2004). In line with this, the statistical significance of the environmental variables in explaining the total variation in species distribution was carried out using Monte-Carlo permutation test, using a forward selection of CANOCO. Statistical analysis was also carried out to find significance correlation between environmental variables by calculating a matrix of Pearson’s correlation coefficient. MINITAB statistical software version 14.13 (Anon., 2004) was used to analyze the correlation analysis.

Results

Plant community assessment

The classification analysis of the 74 quadrates using TWINSpan method resulted in three different community types (Table 1) and these community types were further refined in the synoptic table (Table 2). Based on the dominant and/or characteristic species in the community type the three community types were denoted as:

I. *Combretum collinum-Acacia sieberiana-Balanites aegyptiaca* type

This community type was distributed between 744 m and 830 m a.s.l. altitudinal range and consisted of 10 quadrates with 49 species. In this community, *Combretum collinum* was the dominant species in the tree layer and *Acacia sieberiana*, *Balanites aegyptiaca* and *Tamarindus indica* were the characteristic species in the tree layer. *Strychnos innocua*, *Dichrostachys cinerea* and *Ziziphus abyssinica* were dominant in the shrub or tree layer while *Acacia polyacantha* was the characteristic species in this layer. *Indigofera longibarbata* was dominant species in the field layer. *Hypoestes forskalii* and *Hygrophilia schulli* were also the dominant species in the field layer.

II. *Boswellia papyrifera-Lannea fruticosa-Pterocarpus lucens* type

This community type was distributed between 728 m and 792 m a.s.l. altitudinal range and consisted of 50 quadrates with 74 species. In this community, *Boswellia papyrifera*, *Lannea*

fruticosa and *Pterocarpus lucens* were the dominant species in the tree layer. Other species dominating the tree layer include *Cobretum adenogonium*, *Combretum molle* and *Grewia bicolor*. *Terminalia laxiflora*, *Albizia lophantha* and *Diospyros abyssinica* were the characteristic species in the tree layer, while *Ximonia Americana* was in the dominant species in the shrub or tree layer. In this type, *Monechma ciliatum* was the dominant species in the field layer. *Solanum anguivi*, *Allophylus rubiflorus* and *Ipomoea tenuirostris* were also the dominant species in the field layer.

III. *Sterculea setigera*-*Anogeissus leiocarpa*-*Dalbergia melanoxydon* type

This community type was distributed between 766m and 932m a.s.l. altitudinal range and consisted of 14 quadrates with 44 species. *Sterculea setigera*, *Lannea fruticosa* and *Dalbergia melanoxydon* were the dominant species in the tree layer in the community. *Boswellia pirottae* was also the dominant species in the tree layer, while *Pennisetum pedicellatum* was the dominant species in the field layer including other species like *Panicum monticola*, *Bidens pilosa*, *Hibiscus cannabinus* and *Zinnia peruviana*.

Similarity, diversity and evenness of community types

Generally, the results of the Shannon-Weiner index indicated that all the three community types showed good diversity (Table 3). There were also fair evenness and small dominance in all types. However, based on the diversity curves (Figure 2) and Sorensen similarity coefficient analysis all community types were different. Patterns of the three communities were different owing to their difference in numbers of quadrates, species richness and diversity distribution. In terms of species richness the highest similarity coefficient was 0.49 (49%) observed between community type II and III. The dissimilarities between type I and II, and between type I and III were 0.60 (60%), and 0.65(65%), respectively.

Table 2. Synoptic phytosociological table for the community types.

Community Types	I	II	III
Size	1 0	5 0	1 4
<i>Combretum collinum</i>	4.00	1.58	0.36
<i>Acacia sieberiana</i>	2.10	0.00	0.00
<i>Balanites aegyptiaca</i>	1.70	0.00	0.00
<i>Strychnos innocua</i>	1.70	0.60	0.36
<i>Dichrostachys cinerea</i>	1.60	0.44	0.00
<i>Ziziphus abyssinica</i>	1.50	0.10	0.00
<i>Acacia polyacantha</i>	1.20	0.00	0.00
<i>Indigofera longibarbata</i>	0.80	0.50	0.71
<i>Tamarindus indica</i>	0.60	0.00	0.00
<i>Albizia melanoxylo</i>	0.50	0.00	0.36
<i>Hypoestes forskoolii</i>	0.40	0.20	0.14
<i>Hygrophilia schulli</i>	0.30	0.28	0.14
<i>Boswellia papyrifera</i>	0.70	4.16	2.79
<i>Lannea fruticosa</i>	3.10	4.14	1.50
<i>Pterocarpus lucens</i>	1.60	3.90	0.71
<i>Cobretum adenogonium</i>	0.80	1.34	0.36
<i>Terminalia laxiflora</i>	0.00	1.08	0.00
<i>Albizia lophantha</i>	0.00	0.86	0.00
<i>Ximonia americana</i>	0.50	0.84	0.00
<i>Monechma ciliatum</i>	0.50	0.64	0.36
<i>Combretum molle</i>	0.40	0.62	0.00
<i>Convolvulus Kilimandschari</i>	0.00	0.46	0.00
<i>Solanum anguivi</i>	0.00	0.24	0.00
<i>Allophylus rubiflorus</i>	0.00	0.22	0.00
<i>Grewia bicolor</i>	0.20	0.22	0.21
<i>Diospyros abyssinica</i>	0.00	0.20	0.00
<i>Ipomoea tenuirostris</i>	0.00	0.16	0.00
<i>Sterculea setigera</i>	2.40	2.20	6.07
<i>Anogeissus leiocarpa</i>	4.80	2.18	5.29
<i>Dalbergia melanoxylo</i>	0.00	0.10	2.14
<i>Boswellia pirottae</i>	0.70	0.24	1.36
<i>Pennisetum pedicellatum</i>	0.90	1.22	1.36
<i>Panicum monticola</i>	0.40	0.10	0.50
<i>Bidens pilosa</i>	0.00	0.22	0.43
<i>Hibiscus cannabinus</i>	0.00	0.22	0.29
<i>Zinnia peruviana</i>	0.00	0.24	0.29

Values are the product of average cover-abundance value and frequency in the type. Only species with at least one value ≥ 0.15 were included. Values in bold refer to the occurrences as characteristic species which were used as the naming of each type. The sequence of types follows roughly the arrangement in the ordination diagram in Figure 6).

Table 3. Diversity and evenness of three community types.

Diversity Indices	I	II	III
Shannon	3.43	3.55	3.08
Shannon Evenness	0.63	0.48	0.51
Dominance	0.05	0.05	0.08
Species Richness	49	74	44

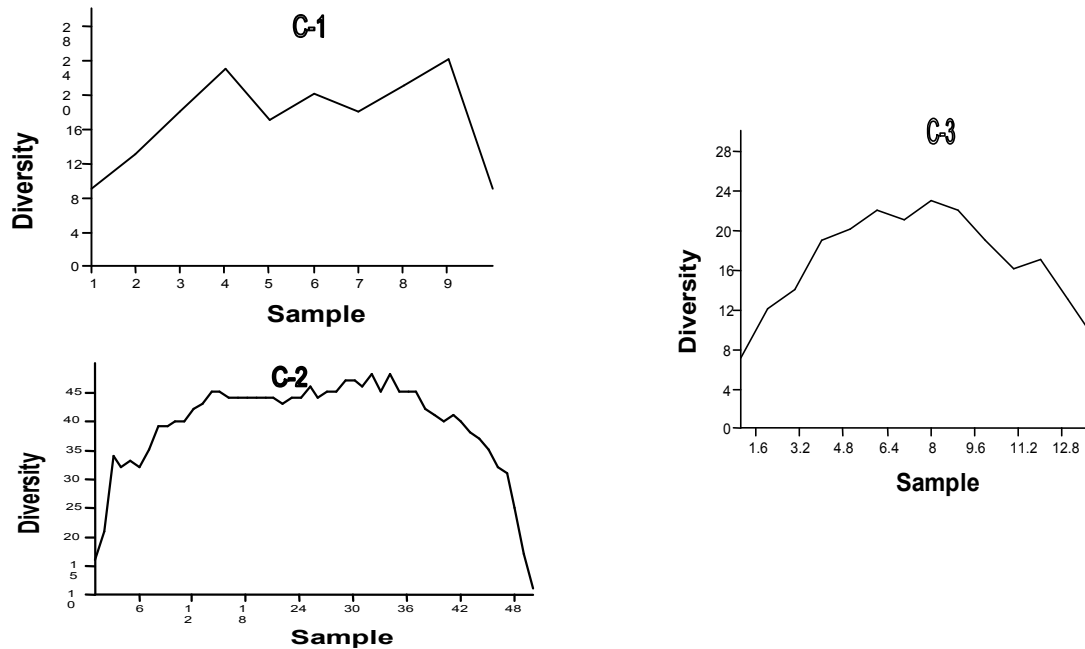

Figure 2. Diversity curves of three community types (C-1 = Community I, C-2 = Community II and C-3 = Community III).

Ordination

Canocial correspondence analysis of quadrates (Figure 3) showed the following relationship between the total vegetation data and the environmental variables. Axis 2 reflected electrical conductivity (EC), pH, moisture, and cation exchange capacity (CEC), while axis 1 revealed a gradient of altitude (Alt). The canocial correspondence analysis coefficients (Table 4) revealed that EC and moisture were the most significant variables in determining the variation in species composition, followed by pH and CEC in axis 2. The eigenvalues for the first axis of the species/environment biplot was 0.195 and the second axis is 0.179, representing 30.7% and 58.9% of the total variance, respectively. In other words, the first two axes account for 89.6% of the variance in the species/environment data implying the constraint analysis of the first two axes was fairly enough in explaining floristic and environmental data. According to Monte-Carlo significance test (Table 4), altitude was the most statistically significant environmental variable in determining the general species distribution and association, followed by moisture and electrical conductivity. However, pH and CEC are non-significant in explaining the total species distribution patterns in the woodland.

Table 4. Correlations of species ordination axis with environmental variables, eigenvalues and percentage variances explained from canonical correspondence analysis of the first two axes (axis1 and axis 2).

Factors	Axis 1	Axis 2	Monte-Carlo Test (at p<0.05)		
			Eigenvalues	F-ratio	P
Altitude	0.7905	0.2145	0.183	1.801	0.002
Moisture	-0.1444	-0.6196	0.133	1.295	0.034
Electrical Conductivity	-0.4787	0.5024	0.154	1.508	0.036
pH-H ₂ O	-0.3421	-0.1825	0.090	0.871	0.728
Cation Exchange Capacity	-0.1361	-0.0835	0.083	0.803	0.86
Eigenvalue	0.195	0.179	Axis 1	1.808	0.044
Species-environment correlations	0.863	0.821	All Axes	1.255	0.012
% variance of species-environment relation	30.7	58.9			

As to the derived three community types distribution and association pattern with the environmental variables (Figure 4), types were emerged to the right and left of the diagram. However, due to the fact that community type I and II showed overlapping at large, ordination for only community type II and III was performed to reveal the clear separation (Figure 5). Generally, from the ordination results, it was observed that species of community type I occurred more along moisture gradient and are species that their association was highly explained by moisture. Species of community type III occurred along with electrical conductivity and are species that their association and distribution is highly explained by electrical conductivity (EC). The distribution of the species in community type II was highly explained by moisture and altitude.

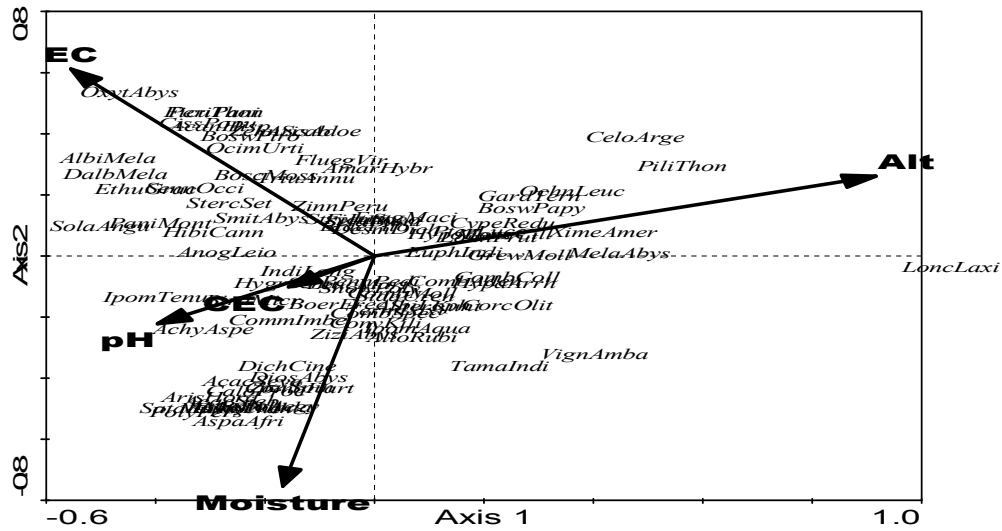

Figure 3. Species/Environment biplot ordination diagram of Metema vegetation from canonical correspondence analysis. Associated correlations, eigenvalues and percentage variances explained are given in Table 4. And note that names of species were made from the first four letters from species and genera. See Appendix 1 for the names of the species.

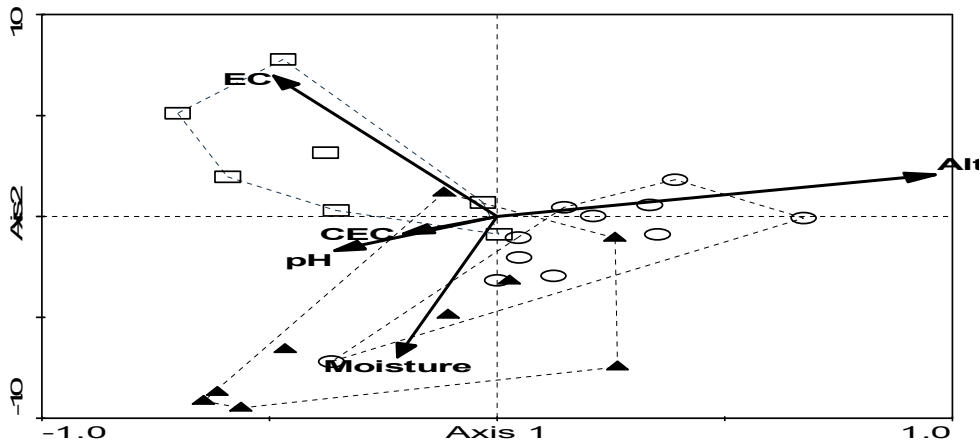

Figure 4. Canocal correspondence ordination of the three communities. Each symbol represents the weighted average of one species. Each envelop encircled around different symbols represent the three different communities: I (▲), II (○), and III (□).

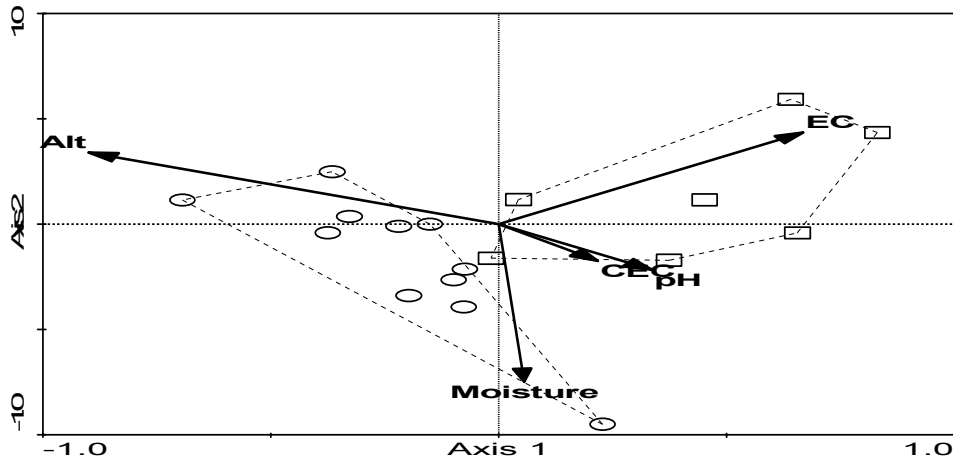

Figure 5. Canocial correspondence ordination of the two communities. Each symbol represents the weighted average of one species. Each envelop encircled around different symbols represent the two different communities: II (○) and III (□).

Correlation of environmental variables

Cation exchange capacity (CEC) had strong positive correlation with electrical conductivity (EC), pH, and moisture. But, CEC had significant and negative correlation with altitude (Table 5). EC had significant and positive correlation with pH and negative correlation with altitude. pH had significant and negative correlation with altitude and positive correlation with moisture. Moisture had significant and strong negative correlation with altitude (Table 5).

Table 5. Pearson's product moment correlation coefficients between the environmental variables.

	CEC	EC	pH	Moisture	Altitude
CEC	-				
EC	0.493***	-			
pH	0.881***	0.431***	-		
Moisture	0.664***	-0.024ns	0.772***	-	
Altitude	-0.274*	-0.361**	-0.428***	-0.319**	-

***, **, * and ns denote significant differences at $p < 0.001$, $p < 0.01$, $p < 0.05$ and non significant differences, respectively.

Discussions

Community types

According to Clements (1916 and 1992) as cited by Kent and Coker (1992), plant community are seen as clearly recognizable and definable entities, which repeat themselves with great regularity over a given region of the earth's surface. This study assessed whether there were or not repetition of the three community types of the Metema woodland in other previously reported community types from other dryland parts of Ethiopia. It was found that the community types of Metema woodland were completely different from community types so far discovered in other dryland areas of the country. For instance, Gemedo Dalle *et al.* (2005) had identified eight plant communities: *Acacia drepanolobium-Pennisetum meziamum*, *Bidens hildebrandtii-Chrysopogon aucheri*, *Chrysopogon aucheri-Commiphora africana*, *Cenchrus ciliaris-Chrysopogon aucheri*, *Acacia bussei-Pennisetum meziamum*, *Commiphora erythraea-Sansevieria ehrenbergi*, *Acacia mellifera-Setaria verticillata* and *Heteropogon contortus-Hildebrandtia obcordata* in Borana lowland. Similarly, Haileab Zegeye *et al.* (2005) also identified nine community types in the Rift Valley area: *Euphorbia tirucalli-Acacia tortilis-Euphorbia abyssinica*, *Ficus vasta-Ficus ingens-Ficus sycomorus*, *Steganotaenia araliacea-Maerua triphylla-Cussonia holstii*, *Euphorbia tirucalli-Solanum schimperianum-Acacia tortilis*, *Justicia schimperiana-Pavetta gardeniifolia-Cordia monoica*, *Olea europaea-Juniperus procera-Dodonaea angustifolia*, *Senna singueana-Pavetta gardeniifolia-Grewia velutina*, *Aeschynomene elaphroxylon-Sesbania sesban* and *Pappea capensis-Rhus natalensis-Maytenus senegalensis*.

This may suggest that the Metema woodland is an isolated system of its own because of the past and present interactions of local biotic and abiotic factors such as temperature, edaphic, rainfall, anthropogenic, faunal, topographic and geographic factors. However, community type II, *Combretum adenogonium-Anogeissus leiocarpa*, of this study showed similarity with one community out of the seven community types identified from Gambella region by Tesfaye Awas *et al.* (2001). According to this report, *Combretum adenogonium*, *Pterocarpus lucens*, *Terminalia laxiflorus* along with *Anogeissus leiocarpa* were the dominant species in the tree layer of *Combretum adenogonium-Anogeissus leiocarpa* type.

In this study similarly, *Combretum adenogonium*, *Pterocarpus lucens* and *Terminalia laxiflorus* were the dominant species in the tree layer of community type II i.e., *Boswellia papyrifera-Lannea fruticosa-Pterocarpus lucens*.

This similar finding further ratifies the earlier suggestion that the fact that Gambella and Metema are located in proximity and adjoining geographical areas might made them similar in their emerged plant associations as compared to Borana and Rift Valley areas, which are not in proximity with Metema woodland. This implied that the further we went to the closer geographical location, the more probability we would have in finding similar associations of plant communities. The complex interaction of environmental variables along spatial gradients will form a complex environmental gradient that characterizes the nature and distribution of communities along landscapes (Urban *et al.*, 2000).

Environmental analysis

Plant community distribution along the geographical gradients is manifestation of physical factors such as elevation gradients, soil heterogeneity and microclimate, biotic response to the physical factors, and historical disturbances (Urban *et al.*, 2000). In the current study, it was noticed that the distribution and association pattern of community type I was explained by moisture while the patterns of type II and III by both moisture and altitude, and electrical conductivity, respectively. Several researchers (Friis, 1992; Tamrat, 1993; Kumlachew and Tamrat, 2002) have reported the influence of altitudinal gradient on plant community distribution. Altitude had been recognized as an important environmental factor that affects radiation, atmospheric pressure, moisture and temperature, all of which have strong influence on the recruitment, growth and development of plants and the distribution of vegetation types. In agreement with the above authors, this study also found that altitude was the most significant environmental variable that determined the general occurrence and distribution pattern of plant community in the Metema woodland vegetation. While, moisture and EC were the second and third most significantly important environmental variables in determining the pattern of community occurrence and distribution.

Conclusions and Recommendations

The current result would make future management of the vegetation feasible, since recognition of more or less homogeneous communities and the associated environmental settings facilitate the choice of appropriate managerial interventions. The ordination analysis revealed that community type I emerged with the gradient of moisture while that of type II with altitude and moisture, and type III with electrical conductivity. Of all the environmental factors studied, altitude was the most significant variable in explaining the total vegetation variations followed by moisture and electrical conductivity. However, cation exchange capacity and pH were non-significant in doing so for the Metema woodland. This research finding was found to be similar with various studies made in the country which reported that altitude had been the most important environmental variable in determining the occurrence and distribution of plant communities. In conclusion, this study recommended that any intervention should take into account the three community types and their environmental settings to make the intervention more feasible. Finally, further research has to be initiated to fill the gaps of this research, especially investigation on the area of socio-economic and ethnobotanical perspectives.

References

- Akimaliev, J. 2005. Soil Degradation in Kyrgyzstan and Measures of Soil Improvement. In: El-Beltagy, A. and Saxena, M. C. (Eds.). Sustainable Development and Management of Drylands in the Twenty-first Century. Proceedings of the Seventh International Conference on the Development of Drylands, 14-17 September 2003, Tehran, Iran. ICARDA, Aleppo, Syria. Xvi+ 63pp.
- Friis, I. 1992. Forests and Forest Trees of Northeast Tropical Africa, HMSO Kew Bulletin Additional Series 15, London. 396 pp.
- Gemedo Dalle. 2004. Vegetation ecology, range condition and forage resources evaluation in the Borana lowlands, Southern Borana, PhD Dissertation, Gottingen, Germany.

- Gemedo Dalle, Brigitte, L.M. and Johannes, I. 2005. Plant community and their species diversity in the semi-arid rangelands of Borana lowlands, southern Oromia, Ethiopia. *Community Ecology* 6 (2): 167-176.
- Gotelli, N.J. and Colwell, E.K. 2001. Quantifying biodiversity: procedures and pitfalls in the measurement and comparison of species richness. *Ecological Letters*, 4: 379-391.
- Haileab Zegeye, Demel Teketay, and Ensermu Kelbessa. 2005. Diversity, regeneration status and socio-economic importance of the vegetation in the islands of Lake Ziway, south-central Ethiopia. *Flora* 201: 483–498.
- Hammer, Ø., Harper, D.A.T. and Ryan, P.D. 2001. PAST-Palaeontological Statistics software package for education and data analysis, Palaeontological Electronica.
- Hill, M.O. and Šmilauer, P. 2005. TWINSpan for Windows version 2.3. Centre for Ecology and Hydrology & University of South Bohemia, Huntingdon & Ceske Budejovice.
- Kent, M. and Coker, P. 1992. *Vegetation Description and Analysis: A practical approach*. Belhaven Press, London.
- MINITAB. 2004. MINITAB for Windows release 14.13. Minitab Inc.
- Sisay Asfaw. 2006. Effects of Fire and Grazing on Woody Species Composition, Population Structure, Soil Seed Banks and Soil Carbon in Woodlands of North Western Ethiopia. MSc Thesis. BOKU University, Vienna.
- Šmilauer, P. 2002a. CanoDraw for Windows Version 4.0. Biometrics-Plant Research International, Wageningen University and Research Centre, The Netherlands
- Šmilauer, P. 2002b. WCanoImp Help File. Biometrics-Plant Research International, Wageningen University and Research Centre, The Netherlands.
- Tamrat Bekele. 1993. Vegetation ecology of remnant afro-montane forests on the Central plateau of Shewa, Ethiopia. *Acta Phytogeographica Suecica* 79: 1-59.
- Ter Braak, C.J.F. and Šmilauer, P. 2002. Canoco for Windows Version 4.5. Biometrics-Plant Research International, Wageningen University and Research Centre, The Netherlands.
- Tesfaye Awas, Tamrat Bekele and Sebsebe Demissew. 2001. An ecological study of the vegetation of Gambella region, southwestern Ethiopia. *SINET: Ethiopian Journal of Science* 24: 213-228.

Urban, D.L., Miller, C., Halpin, P.N. and Stephenson, N.L. 2000. Forest gradient response in Sierran landscapes: the physical template. *Landscape Ecol.*15: 603-620.

Van der Maarel.1979. Transformation of cover abundance values in phytosociology and its effect on Community. *Vegetatio* 39: 47-114.

Whittaker, R.H. 1972. Evolution and measurement of species diversity. *Forest Ecology and Management* 186 (2003) 61–71.

Adaptation of indigenous economically important multipurpose trees in the dry lowlands of Abergele

Haile Adamu

Sekota Dryland Agricultural Research Center, P.O. Box 62, Sekota, Ethiopia.

Abstract

The study was carried out in 2006-2009 in Abergele, Wag-himra, to determine the adaptability of different indigenous multipurpose tree species. Five economically important multipurpose tree species namely: *Moringa stenopetala*, *Moringa oleifera*, *Tamarindus indica*, *Acacia senegal*, and *Casuarinas equistifolia* were evaluated for their adaptability using RCB design in three replication. Half moon structures were used as moisture conservation technique. Data on root collar diameter, height, and survival rate were collected at every 3 months for 36 months. Data analysis was done with Excel spreadsheet. The result revealed that *Moringa stenopetala* was the most adaptive species with 83.3% survival rate, 330.65 cm height, and 145.83 mm of root collar diameter. *Acacia senegal* was the second adaptive species with 52.08% survival rate, 209.07 cm height, and 43.67 mm root collar diameter. Therefore, scaling up and demonstration of *Moringa stenopetala* and *Acacia senegal* in Abergele and similar areas in Wag-himra is recommended. This study further recommended that planting of these species should be done using half moon structure as moisture conservation techniques.

Keywords: Abergele, adaptation, dryland, Moringa, root collar diameter, survival rate.

Introduction

The United Nations Environment Program (UNEP) has estimated that 35 million km² of the dryland regions of the world, an area approximately the size of both North and South America, are affected by desertification. Nearly 20 million km² of this area has been classified as being subjected to “high” and “very high” desertification risk. Equally important is the fact that 30,000 km² are reduced to a state of “uselessness” every year, a loss that is expected to continue into the future unless remedial actions are taken (FAO, 1989). Worldwide, one billion people in 110 nations earn their livelihoods directly in drylands. Nearly all of these people, and the drylands on which they depend, are at constant risk from land degradation/desertification, which can be the result of climate change or

natural phenomena but is more likely to arise from human activity (Laudazi and Lambrou, 2003). There are many factors that trigger desertification, including the effect of drought and climate change, fragile soils and geological erosion, livestock pressure, nutrient mining, growing populations, inadequate/ambiguous property and tenure rights, landlessness and an equitable distribution of assets, poor infrastructure and market access, neglect by policy makers and agricultural and environmental research systems, and the failure of markets to reward the supply of environmental services (Akimaliev, 2005).

Abergele is one of such dryland parts of Ethiopia located in the Northeastern part of the Amhara Regional State, Ethiopia. Like other dryland parts of the country, land degradation is rife in Abergele area because of over exploitation of the woodlands and farming of the fragile lands. Transgression of agriculture towards the natural woodland, burning and overgrazing resulted in the clearing of woodlands. This in turn accelerated soil erosion and destroyed the soil and floristic diversity of the area. To address these overriding problems of the area, some research activities like adaptability experiment of different important tree and shrub species is paramount. This is due to the fact that there are some promising species, both in and out of Ethiopia which could withstand the existing harsh climatic conditions. Such species are said to be the species that can survive and thrive in a changing climate, probably they will be the dominant species ones in the aftermath of environmental calamity. The objective of this research was, therefore, identify the most adaptive indigenous tree species which have multipurpose use and are economically important.

Materials and methods

Five economically important indigenous multipurpose tree species namely: *Moringa stenopetala*, *Moringa oleifera*, *Tamarindus indica*, *Acacia Senegal*, and *Casuarinas equistifolia* were evaluated in 2006-2009 for their adaptability using RCB design in three replication. Half moon structures were used as moisture conservation technique. Data on root collar diameter, height, and survival rate were recorded every 3 months for 36 consecutive months. The collected data were analyzed using Excel Spread Sheet.

Results and discussion

The results of survival rate data revealed that *Moringa stenopetala* was the most adaptive species with 83.3% survival rate followed by *Acacia Senegal* and *Moringa oleifera*. *Casuarinas equistifolia* was the least adaptive species which was not more reckoned as alive after nine month (Figure 1).

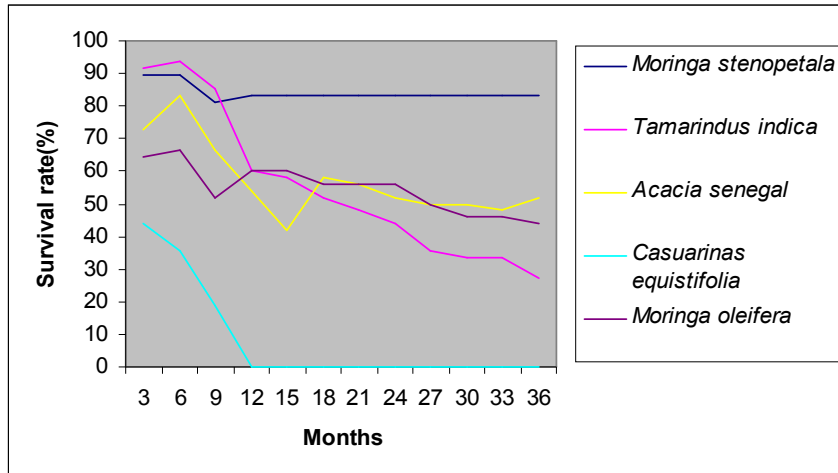

Figure 8. Survival rate of species across months at Abergele.

Plant height was highest for *Moringa oleifera* (342.5 cm) and *Moringa stenopetala* (330.65 cm) followed by *Acacia Senegal* (209.07 cm) and *Tamarindus indica* (54.33 cm) (Figure 2).

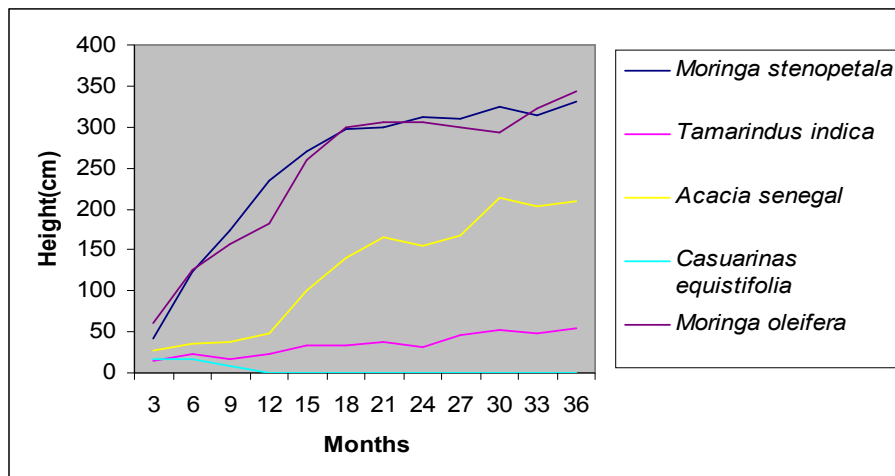

Figure 9. Plant height of the species across months at Abergele.

Root collar diameter was highest for *Moringa stenopetala* (145.83 mm) followed by *Moringa oleifera* (83.25 mm), *Acacia Senegal* (43.67 mm) and *Tamarindus indica* (13.25 mm) (Figure 3).

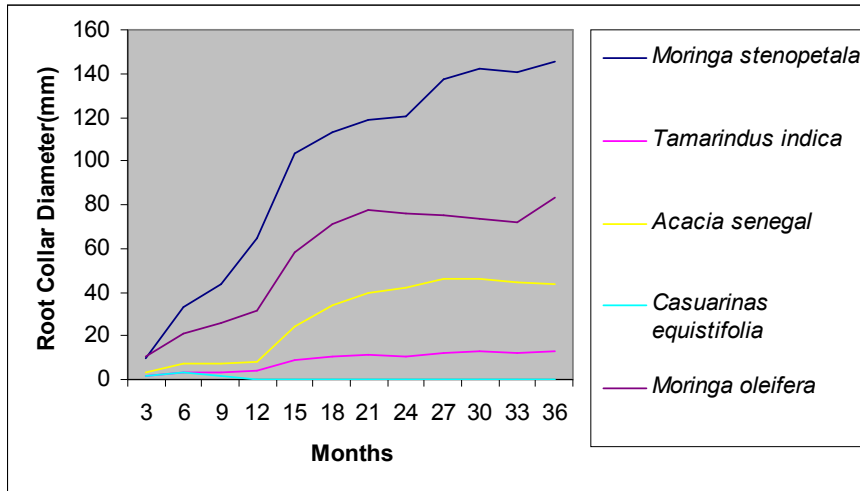

Figure 10. Root collar diameter of the species across months at Abergele.

Generally, from overall growth performance points of view, *Moringa stenopetala* and *Acacia senegal* (Figure 4) were the most adaptive species in the highly moisture stressed Abergele.

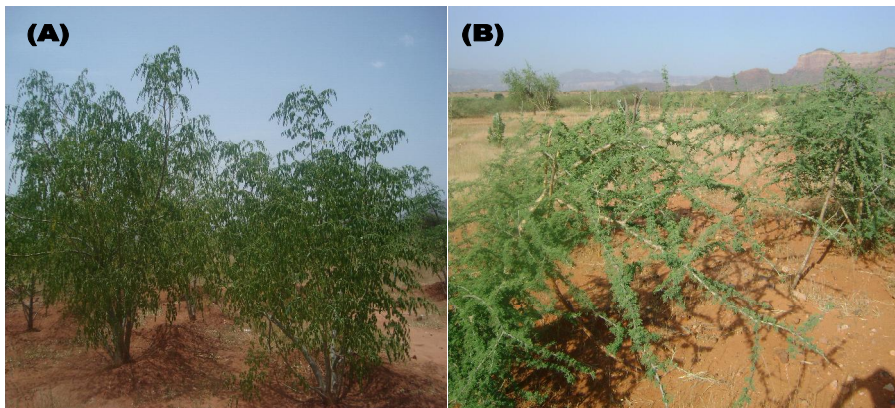

Plate 1. *Moringa stenopetala* (A) and *Acacia Senegal* (B)

Conclusion and Recommendations

Despite the fact that Abergele area is one of the most moisture stressed areas of Amhara region, which is the pivotal hindrance for growth and survival of trees and shrubs, this research finding came up with results that prove the previous prevailing wrong notions as wrong. Especially, the growth performance of *Moringa stenopetala* and *Acacia senegal* revealed that tree seedlings can grow well in such area as long as we could choose best species which can thrive well in harsh environments. Scaling up and demonstration of *Moringa stenopetala* and *Acacia Senegal* species in Abergele and similar areas in Waghimra with a special focus on their utilization and silvicultural management is recommended. It is further recommended that planting of these species should be done using half moon structure as moisture conservation techniques.

References

- Akimaliev, J. 2005. Soil degradation in Kyrgyzstan and measures of Soil Improvement. In: El-Beltagy, A. and Saxena, M. C. (Eds.). Sustainable Development and Management of Drylands in the Twenty-first Century. Proceedings of the Seventh International Conference on the Development of Drylands, 14-17 September 2003, Tehran, Iran. ICARDA, Aleppo, Syria. Xvi+ 63pp.
- FAO (Food and Agricultural Organization of the United Nations). 1989. Role of Forestry in Combating Desertification. FAO Conservation Guide 21, Rome, Italy. 1-20pp.
- Laudazi, M. and Lambrou, Y. 2003. Gender and Sustainable Development in Drylands: An Analysis of Field Experiences. In: Shaw, J. and Monsieur, C. (Eds). Food and Agriculture Organization of the United Nations. Sustainable Development Department. Gender and Population Division. 14p.

Instructions to Authors

Authors are requested to pay special attention to the instructions given below for preparation of their manuscript.

1. Content of the paper

The papers should be organized in the following manner:

- a) **Title:** The title should be concise but informative. Not more than 13 words.
- b) Author(s) name(s), and the name(s) and address(s) of the center/institution(s) where the work was carried out should follow the title.
- c) **Abstract:** The abstract should be condensed to a maximum of 200 words and should be intelligible by it self. It should have objectives, methodologies, results, and a conclusion in a single paragraph.
- d) **Introduction:** This section of the manuscript should indicate the explanation or fundamental hypothesis on why the study or the research was conducted. Gaps found in previous related literatures and objectives should also be stated.
- e) **Materials and methods:** Description of the environment, materials used, procedures followed, experimental design and statistical analysis applied are briefly explained here. Year of accomplishment should also be indicated. This has to enable others to repeat one's experiment.
- f) **Results and discussion:** *Result*-is the core of the paper. Simply and clearly stated presentation of what is found with the investigation as related to what is stated in the introduction part. It includes un repetitive presentation of

representative data. *Discussion*- should explain what the result means and its practical significance and implication for future study. Discusses whether it agrees or disagrees with previously published work. Based on this conclusions are stated with evidence and recommendations can be given for follow up.

g) **Acknowledgments:** Acknowledgments, if any, may be given immediately following results and discussion section very briefly.

h) **References:** Only publications cited in the text should be given in the references. All literatures cited should be closely relevant to the author's work. Exhaustive list should be avoided, not more than 10 except under special condition. References should be arranged in alphabetical and chronological order (from older to recent). Checking the accuracy of references is the responsibility of authors. In the text, references should be presented in the author-year style. E.g. (Tan, 1978) or Tan (1978); (Lim and Aziz,1979) or Lim and Aziz (1979). When there are three or more authors (Tan *et al.*,1979) Tan *et al.*, (1979).

References should be listed according to the following format. *Note:* names of Ethiopian authors are written fully.

Journal Article

Mabbayad, M.O. and Moody,K. (1985). Improving butachlor selectivity and weed control in wet -seeded rice. *Journal of Plant Protection in the Tropics* 2(2): 117-124.

Beyene Chichaibellu, Coppock, C.E. and McDowell R.E.(1977). Laboratory evaluation and estimation of nutritive values of some Ethiopia feedstuffs. *J. Assoc. Adv. Agric. Sci Africa* 4(2):9-23.

Book

Quinn, G.P., and Keough M.J (2002). *Experimental design and data analysis for biologists.* Cambridge university press, Cambridge.

Edited works (Chapter in a book or paper in a proceedings)

Loegering, William Q. (1984). Title of the chapter/paper . P. 165-192. *In* William R. Bushnell and Alan P. Roelfs (eds.) title of the book/the proceedings Academic Press, Orlando, Florida.

Un Published reports

Huxley, P.A.(1986) Rationalizing research on hedgerow intercropping: an overview. ICRAF Working Paper 40. Nairobi:ICRAF. P66-75.

Personal communications are not included in a reference list. They are simply listed in the text as: (Anthony Youdeowei, Pers.comm.) or simply as (personal communication).

2. The format

The manuscript has to be typed on one side only, double spaced on A4 sized paper and margins of 25,30, 35 and 25 mm on top, bottom, left and right margins respectively. The font type has to be *times new roman* through out . The font size of the text has to be 12 unless an otherwise specified below. Scientific names have to be written following standard binomial nomenclature.

Except under special recommendation, the manuscript should not be more than 3500 words excluding illustrations. Or totally a maximum of 5-7 pages.

The title of the manuscript has to be bold and centered, only the first letter written in upper case except under special condition. Author(s) name(s) and the institution to which they are affiliated should be written centered with font size of 10. Main Headings (introduction, materials and methods etc) should be left justified and bolded starting with capital letter. Sub-headings are typed alike the main headings but they are italicized and are not bolded. Figures and illustrations should be in a form suitable for edition and reproduction. They have to be black and white and with high contrast.

Tables should be numbered consecutively as Table 1, Table 2, etc., in the order in which they are first cited in the text. Each table, with its heading, should be typed on a separate sheet. A table should be self explanatory and concise. Table-footnotes should be marked with superscript * (asterisk) and the foot note has to be italicized with font size of 10.

Authors are advised not repeat information in the text presented in the tables or in charts or graphs. Submission of unmanageable and oversized tables may lead to rejection.

All measurements must be reported SI units or metric system. Negative exponentials, like Kg ha^{-1} are recommended in stead of writing as Kg/ha. Point has to be used for decimal as 10.5 to say ten point five. Every three digits have to be separated by space as 10 556. Abbreviations or short hand forms have to be first fully spelt out before they are used in abbreviated/shorthand form in the rest part of the text. The ISO designation for Ethiopian currency is ETB and this has to be used whenever the currency is expressed. Gregorian calendar should be used for dates, months and years.

3. Submission

Two hard copies of manuscript should be submitted to the respective directorates or secretaries of the respective editorial committees not later than 45 days after the papers are presented on the conference. The range includes time required for postal transfer. Soft copy should be submitted with in the same time on diskette or as attachment to e- mail.

4. Correspondence

Where a paper has joint authors, one author must accept responsibility for all correspondence.

The Editorial committee or the institute shall take no responsibility for the loss of the manuscripts in the process of mailing. The authors are advised to retain copies of their submission.

5. Editorial Committees

Each directorate has its own editorial committee (for crops, livestock and natural resources management research that includes forestry, soils and water management and agricultural mechanization). Each editorial committee is led by the head of the respective directorate. All the three editorial committees are accountable to the deputy director general of the institute in order to maintain uniformity in the publication of proceedings and to monitor the overall activities of the annual conference and its regular implementation. The final decision on the papers presented is made by the respective editorial committees taking into consideration the inputs from the participants during the annual conference. Accepted papers will be further evaluated and commented by senior reviewers and sent back to the authors for corrections. The final editorial work will be done by members of the respective editorial committee which will be made ready for printing.